

WASHDOWN HYGIENIC DRIVES

GENERAL CATALOGUE



REGISTERED
DESIGN
MADE IN ITALY

CLEAN-GEARTECH





CLEAN-GEARTECH

HYGIENIC DESIGN GEARBOXES

MAIN FEATURES

- High pressure clean up
- Pooling free mounting
- Sealed holes
- Sealed oil plugs
- Simple washing
- Smooth surfaces
- No plastic plugs

SECTORS OF USE

- Meat&Poultry
- Beverage
- Fruits & Vegetables
- Animal food
- Seafood / Fish farming
- Bakery
- Confectionery
- Cleaning systems
- Conveyors
- Dairy
- Food packaging
- Food processing
- Freezing Systems
- Mixers Agitators
- Pumps
- Ventilators
- Chemical
- Cosmetics
- Pharmaceutical
- Marine and fishing

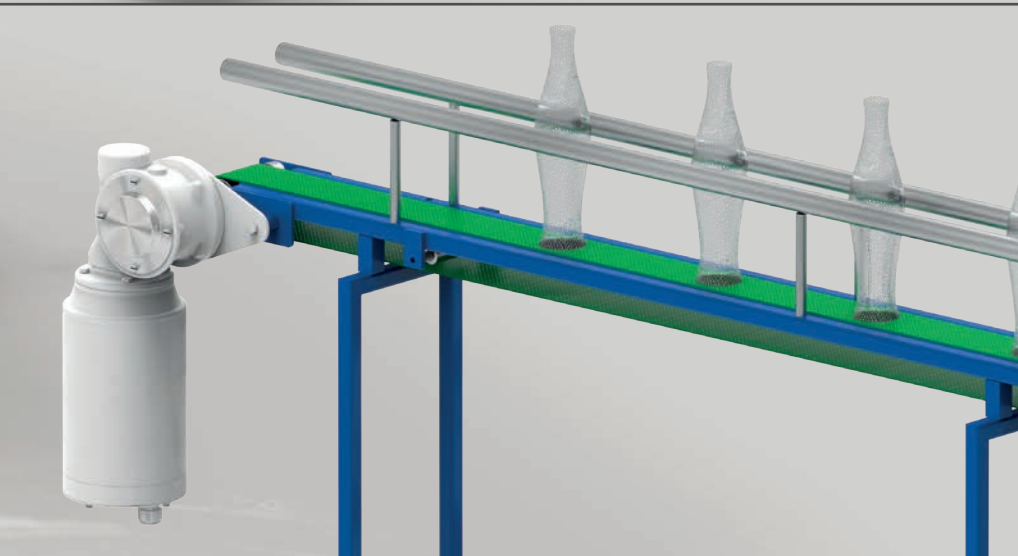
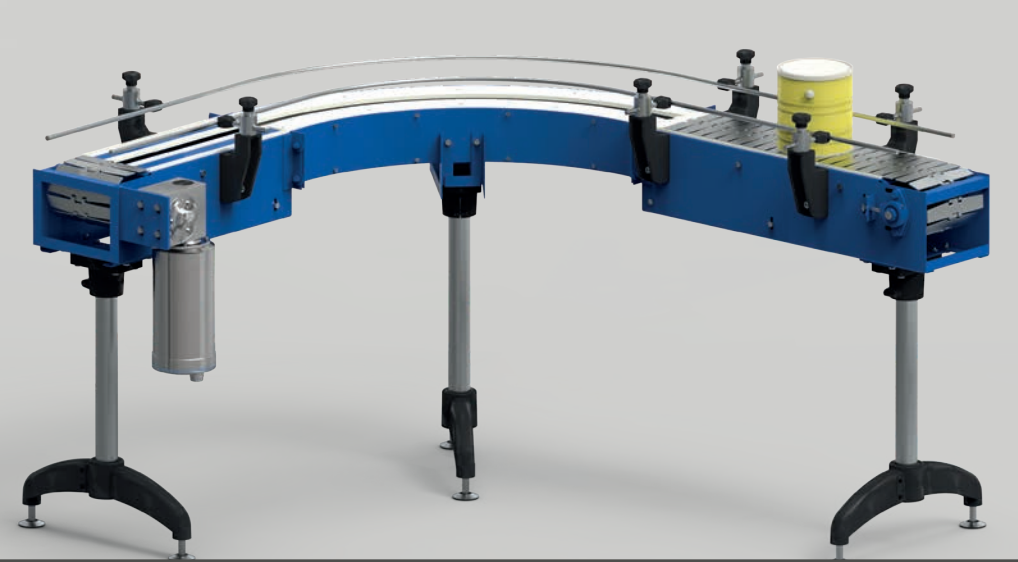

The CLEAN-GEARTECH philosophy

Protection level ↑

BEST

AISI 316L
AISI 304

Full stainless steel, the best for every application.

Completamente in acciaio inox, la miglior soluzione per qualsiasi applicazione.

Smooth surface aluminum worm gearboxes with additional white protective paint.

Riduttori a vite senza fine in alluminio a superficie liscia con ulteriore vernice protettiva bianca.

The starting base for avoiding dust accumulation.

Design adatto a consentire la miglior pulizia del prodotto. La base di partenza per evitare l'accumulo di polvere.

● VFN



MEDIUM

● VFD on request



BASIC

● VFD



● VFD on request

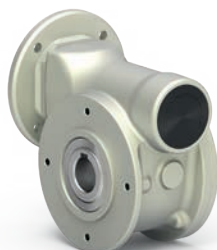

← ● These gearboxes are fully interchangeable on dimensions →

ALUMINUM

AISI 316L

STANDARD

NTT

PAINTED

Smooth surface worm gearboxes for basic cleaning applications

Riduttori a vite senza fine a superficie liscia per applicazioni base

Protective coating ideal for dust and water washing

Rivestimento protettivo anti polvere ideale per lavaggio con acqua

With white protective paint for outdoors and light detergents

Con vernice protettiva bianca per esterni e lavaggi con detergenti leggeri

Stainless Steel worm gearboxes

Riduttori a vite senza fine in acciaio inox

The APM Series

Hygienic aluminum electric motors with protective high resistance coating

Motori elettrici igienici in alluminio con rivestimento protettivo ad alta resistenza

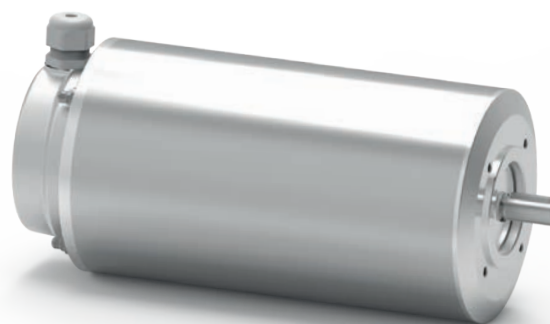

Smooth surface and different materials

RCN



BVN



VFI



RCI



Full stainless steel: the best solution for the resistance to corrosion. Suitable for all applications.

Interamente in acciaio inox: la migliore soluzione per la resistenza alla corrosione. Adatto a tutte le applicazioni.



AISI 316L

AISI 304

FULL STAINLESS FOR THE MOST HARSH APPLICATIONS

Stainless Steel ratio multipliers

Riduttori ad uno stadio in acciaio inox

Stainless Steel helical bevel gearboxes

Riduttori a coppia conica in acciaio inox

Stainless Steel square worm gearboxes

Riduttori a vite senza fine quadrato in acciaio inox

Stainless Steel ratio multipliers

Riduttori ad uno stadio in acciaio inox

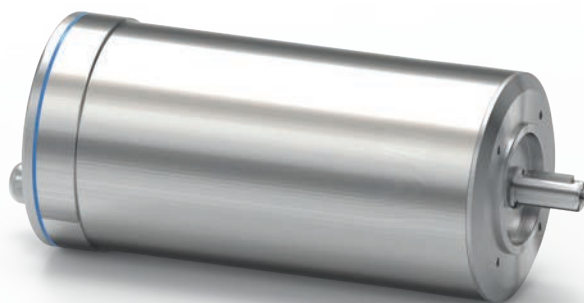

The SPM Series

Hygienic stainless steel 316L electric motors

Motori elettrici igienici in acciaio inox 316L

The VFD Series Smooth surface aluminum worm gearboxes

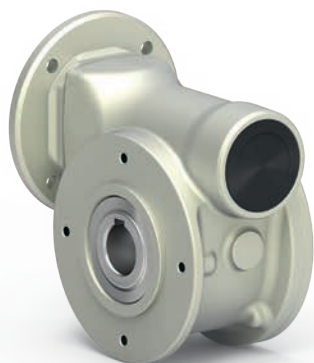

On request



On request

The VFD - STANDARD Series

It is our most economical basic solution to reduce dust accumulation. Also available with aluminum electric motor APM series without ribs.

La serie VFD - STANDARD

E' la soluzione più economica per ridurre l'accumulo di polvere.
Disponibile anche con motore in alluminio senza alette, serie APM.

The VFD - NTT Series

Gearbox with a protective coating to reduce dust accumulation and for water washing. Also available with aluminum electric motor APM series without ribs with protective coating.

La serie VFD - NTT

Riduttore con rivestimento protettivo per ridurre l'accumulo di polvere e per lavaggio con acqua.
Disponibile anche con motore in alluminio senza alette con rivestimento protettivo, serie APM.

The VFD - PAINTED Series

It is also available with protective white paint, providing a good level of protection in medium aggressive environments. See the graph in the next page.

La serie VFD - PAINTED

E' disponibile anche con vernice protettiva bianca che permette un livello di protezione medio per ambienti aggressivi.
Vedere il grafico nella prossima pagina.

VFD certification

worm gearboxes



On request
A richiesta



RCD certification

ratio multiplier



On request
A richiesta



Ratio: 1 / 2.05 ÷ 1 / 9.83



IP69k when combined with on other gearbox

Type Tipo	Torque Coppia	Center distance Interasse	Input power Potenza in entrata	Hollow output shaft Albero cavo in uscita	
				Standard	On request
D30	21 Nm	30 mm	0.06 ÷ 0.18 kW	ø14 mm	-
D45	41 Nm	45 mm	0.09 ÷ 0.37 kW	ø18 mm	ø19 ø20 mm
D50	72 Nm	50 mm	0.12 ÷ 0.75 kW	ø25 mm	ø24 mm
D63	147 Nm	63 mm	0.37 ÷ 1.8 kW	ø25 mm	ø28 ø30 mm
D85	347 Nm	85 mm	0.55 ÷ 4.0 kW	ø35 mm	ø38 mm
211D	20 Nm	30 mm	0.37 ÷ 1.5 kW	ø14 mm	-

THE BASIC PROTECTION

Vacuum impregnated housing

Single piece aluminum alloy housing vacuum impregnated MIL-STD 276.

Design adatto a consentire la miglior pulizia del prodotto. Cassa monoblocco impregnata sotto vuoto MIL-STD 276.

Hardened and ground worm

Hardened and ground worm, teeth radiused for noise reduction.

La vite senza fine è temprata ed i denti sono profilati e raggiati per ridurre il rumore.



Options Coupling

Premium input coupling:

- Direct mounting
- No settings
- No screw

*Giunto in entrata:
- Montaggio diretto
- No settaggi - No viti.*

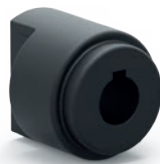

Output hollow shaft

Cast iron hollow shaft. CuSn12Ni (C91700) Nickel bronze worm gear for superior life.

Mozzo in ghisa. Corona in bronzo al Nickel CuSn12Ni (C91700) centrifugato per massima resistenza e durata superiore.



Options Stainless steel hollow shaft in AISI 316L

Mozzo in uscita in AISI 316L.

Hardware

Output male shaft in carbon steel. Zinc plated: feet screws and reaction arms.

Albero maschio in uscita removibile in acciaio. Piedi, viteria e bracci di reazione zincati.



Options Stainless steel hardware

Stainless steel output male shaft, protection cap, feet, screws and reaction arms.

Albero maschio in uscita removibile, coperchietto di protezione, piedi, viteria e bracci di reazione in AISI 316L.



NBR seals

NBR seals on hollow output shaft.

Anelli di tenuta in NBR su mozzo in uscita.



Options Viton seals

Single viton seal for harsh environment.

Anelli di tenuta in viton per ambienti aggressivi.



Twin viton seals with stainless steel 316L shield for IP69K protection.

Doppi anelli di tenuta in viton con schermo protettivo in acciaio inox AISI 316L per protezione IP69K.



On request White protective painting RAL 7035

The graph below shows the behavior of an aluminum gearbox (not painted) and of a gearbox with protective paint during the salt spray test. The time (hours spent in the test) is indicated on the horizontal axis, while the degree of corrosion on the surface of the reducer is indicated on the vertical axis. The curve of the aluminum reducer (not painted) shows that only after about 100 hours of testing the first signs of corrosion are formed (the curve enters the "corrosion starting" zone) and then spreads rapidly ("corrosion" zone). The curve of the reducer with protective coating instead shows that after 1200 hours of permanence in saline mist, there are still no signs of corrosion.



Il grafico seguente riporta il comportamento di un riduttore in alluminio (non verniciato) e di un riduttore con vernice bianca protettiva durante il test in nebbia salina. Sull'asse orizzontale è indicato il tempo (ore di permanenza nel test) mentre sull'asse verticale il grado di corrosione sulla superficie del riduttore. La curva del riduttore in alluminio (non verniciato) evidenzia come solo dopo circa 100 ore di test si formano già i primi segni di corrosione (la curva entra nella zona "corrosion starting") e poi si propaga rapidamente (zona "corrosion"). La curva del riduttore con verniciatura protettiva mostra invece come dopo 1200 ore di permanenza in nebbia salina, non vi siano ancora segni di corrosione.

NSS Neutral Salt Spray Test

Type DCTC 1200 P n° L79 SO 9227:2006 (E) with salt spray test: 5% NaCl gearboxes

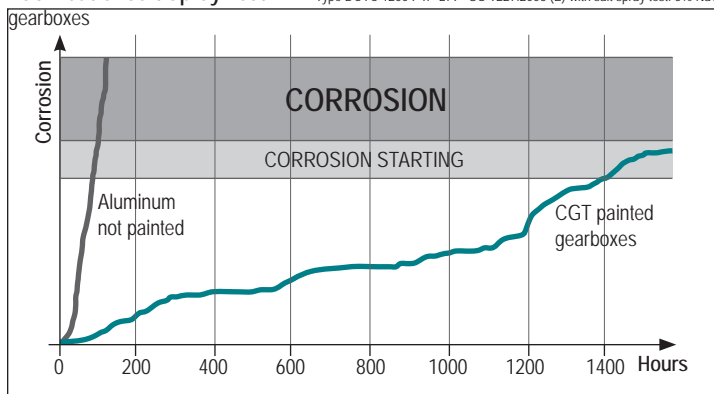

This graph is an indication, since some chemical components may be more aggressive than the salt spray test. Test are suggested on special cases (in case use type "N series", full stainless steel gearboxes).

Il grafico va considerato come indicativo perché altri agenti chimici potrebbero risultare più aggressivi del test in nebbia salina. Sugeriamo prove specifiche nell'ambiente di lavoro e nel caso non vengano soddisfatti i requisiti minimi si consiglia di utilizzare la gamma in acciaio inox "Serie N".

The VFN Series Stainless steel worm gearboxes

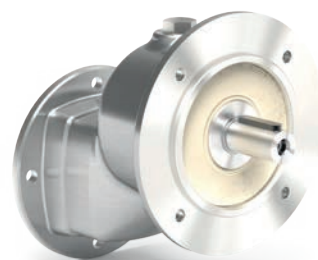

The VFN Series

It is the best solution for the resistance to corrosion. Suitable for all applications. Entirely in stainless steel with smooth surfaces for easy cleaning. Also available with stainless steel motor SPM series.

La serie VFN

E' la migliore soluzione per la resistenza alla corrosione. Adatto a tutte le applicazioni. Interamente in acciaio inox con superfici lisce per facilitare la pulizia. Disponibile anche con motore in acciaio inox, serie SPM.

The RCN Series

It is the best solution where hygiene and cleanliness are required. The ratio multiplier gearbox has smooth surfaces for easy cleaning. Also available with stainless steel motor SPM series.

La serie RCN

E' la migliore soluzione dove è richiesta igiene e pulizia. Il riduttore ad uno stadio ha superfici lisce per facilitare la pulizia. Disponibile anche con motore in acciaio inox, serie SPM.

VFN certification

worm gearboxes



RCN certification

ratio multiplier



Ratio: 1 / 1.57 ÷ 1 / 10.86

IP69k when combined with on other gearbox

Type Tipo	Torque Coppia	Center distance Interasse	Input power Potenza in entrata	Hollow output shaft Albero cavo in uscita	
				Standard	On request
N30	21 Nm	30 mm	0.06 ÷ 0.18 kW	ø14 mm	-
N45	41 Nm	45 mm	0.12 ÷ 0.37 kW	ø18 mm	ø19 ø20 mm
N50	72 Nm	50 mm	0.12 ÷ 0.75 kW	ø25 mm	ø24 mm
N63	147 Nm	63 mm	0.37 ÷ 1.8 kW	ø25 mm	ø28 ø30 mm
N85	347 Nm	85 mm	0.55 ÷ 4.0 kW	ø35 mm	-
211N	20 Nm	30 mm	0.25 ÷ 0.37 kW	ø14 mm	-
411N	38 Nm	38 mm	0.37 ÷ 1.5 kW	ø19 mm	-

THE BEST PROTECTION IN 316L

Housing

Special high tech full stainless steel housing with accurate polished finishing and strong rigidity.

Cassa speciale interamente in acciaio inox estremamente rigida e con finitura lucida accurata.

Viton seals

Single viton seal for harsh environment.

Anelli di tenuta in viton per ambienti aggressivi.



Hardened and ground worm

Hardened and ground worm, teeth radiused for noise reduction.

La vite senza fine è temprata ed i denti sono profilati e raggiati per ridurre il rumore.



Options Twin viton seals

Twin viton seals with stainless steel 316L shield for IP69k protection.

Doppi anelli di tenuta in viton con schermo protettivo in acciaio inox AISI 316L per protezione IP69k.



Options Coupling

Premium input coupling with direct mounting
No settings - No screw.

*Giunto in entrata: Montaggio diretto
No settaggi - No viti.*



Output hollow shaft

Stainless steel hollow shaft in AISI 316L.

CuSn12Ni (C91700) Nickel bronze for superior life.

*Mozzo in acciaio inox 316L.
Corona in bronzo al Nickel CuSn12Ni (C91700) centrifugato per massima resistenza e durata superiore.*



STANDARD POLISHED FINISHING

Finitura lucida standard



Stainless steel hardware

Stainless steel output male shaft, protection cap, feet, screws and reaction arms.

Albero maschio in uscita removibile, coperchietto di protezione, piedi, viteria e bracci di reazione in AISI 316L.

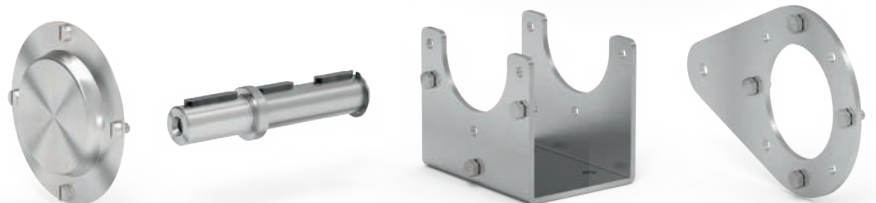

The BVN Series Stainless steel helical bevel gearboxes

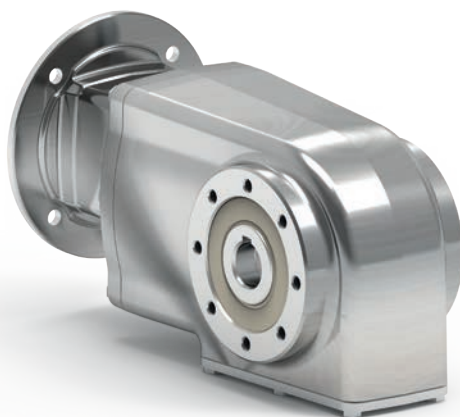

The BVN Series

The best high efficiency solution for the resistance to corrosion. Suitable for all applications.

It is a strong and clean helical bevel gear.

Entirely in stainless steel with smooth surfaces for easy cleaning.

Also available with stainless steel motor SPM series.

La serie BVN

La migliore soluzione ad alta efficienza per la resistenza alla corrosione. Adatto a tutte le applicazioni.

Riduttore a coppia conica resistente e dal design pulito.

Interamente in acciaio inox con superfici lisce per facilitare la pulizia.

Disponibile anche con motore in acciaio inox, serie SPM.

BVN certification

Helical bevel gearboxes



On request
A richiesta



Type Tipo	Torque Coppia	Input power Potenza in entrata	Hollow output shaft Albero cavo in uscita	
			Standard	On request
X42N	130 Nm	0.25 ÷ 1.5 kW	ø25 mm	ø20 mm
X43N	136 Nm	0.12 ÷ 0.37 kW	ø25 mm	ø20 mm
X62N	410 Nm	0.75 ÷ 4.0 kW	ø35 mm	ø30 mm
X63N	410 Nm	0.25 ÷ 1.1 kW	ø35 mm	ø30 mm
X73N	675 Nm	1.1 ÷ 4.0 kW	ø40 mm	-
X74N	675 Nm	0.25 ÷ 1.5 kW	ø40 mm	-

THE BEST PROTECTION IN 316L

Housing

Special high tech full stainless steel housing with accurate polished finishing and strong rigidity.

Cassa speciale interamente in acciaio inox estremamente rigida e con finitura lucida accurata.

Input bore

Input bore is available for IEC and NEMA versions.

Albero in entrata disponibile per versioni IEC e NEMA.



Options Coupling

Premium input coupling with direct mounting
No settings - No screw.

*Giunto in entrata:
Montaggio diretto - No settaggi - No viti.*



Gears

Hardened and ground gears.

Ingranaggi temprati e rettificati.



Output hollow shaft

Stainless steel hollow shaft in AISI 316L.

Mozzo in acciaio inox 316L



Stainless steel hardware

Stainless steel output male shaft, protection cap, feet, screws and reaction arms.

Albero maschio in uscita removibile, coperchietto di protezione, piedi, viteria e bracci di reazione in AISI 316L.



Viton seals

Single viton seal for harsh environment.

Anelli di tenuta in viton per ambienti aggressivi.



Options Twin viton seals

Twin viton seals with stainless steel 316L shield for IP69k protection.

Doppi anelli di tenuta in viton con schermo protettivo in acciaio inox AISI 316L per protezione IP69k.



STANDARD POLISHED FINISHING

Finitura lucida standard

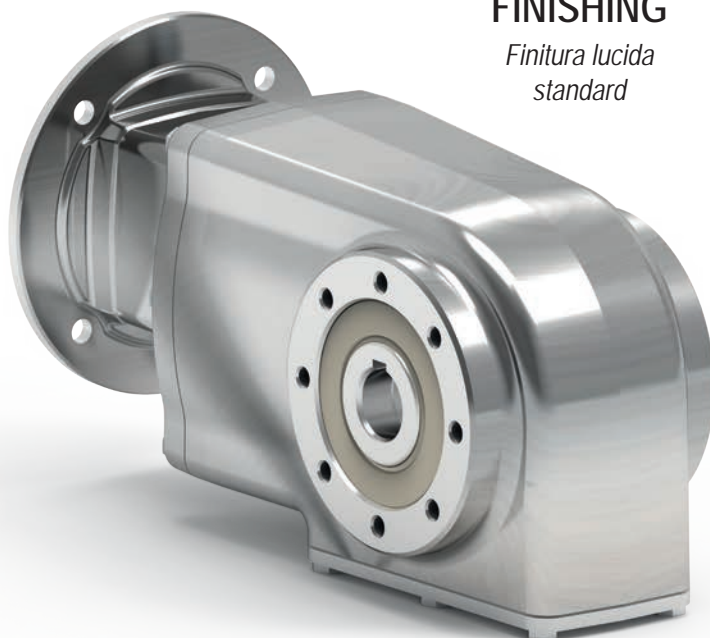

The VFI Series Stainless steel worm gearboxes



The VFI Series

It is the best solution for the resistance to corrosion. Suitable for all applications. Entirely in stainless steel, the surfaces do not have grooves or other elements that could attract dirt. Also available with stainless steel motor SPM series.

La serie VFI

E' la migliore soluzione per la resistenza alla corrosione. Adatto a tutte le applicazioni. Interamente in acciaio inox, le superfici non presentano solchi o altri elementi che potrebbero attirare lo sporco. Disponibile anche con motore in acciaio inox, serie SPM.

The RCI Series

The best solution where hygiene and cleanliness are required. The ratio multiplier gearbox with smooth surfaces for easy cleaning. Also available with stainless steel motor SPM series.

La serie RCI

La migliore soluzione dove è richiesta igiene e pulizia. Il riduttore ad uno stadio con superfici lisce per facilitare la pulizia. Disponibile anche con motore in acciaio inox, serie SPM.

VFI certification

worm gearboxes



RCI certification

ratio multiplier



Ratio: 1 / 1.57 ÷ 1 / 10.86

IP69k when assembled with on other gearbox

Type Tipo	Torque Coppia	Center distance Interasse	Input power Potenza in entrata	Hollow output shaft Albero cavo in uscita	
				Standard	On request
I30	21 Nm	30 mm	0.06 ÷ 0.18 kW	ø14 mm	-
I45	41 Nm	45 mm	0.12 ÷ 0.37 kW	ø18 mm	ø19 ø20 mm
I50	72 Nm	50 mm	0.12 ÷ 0.75 kW	ø25 mm	ø24 mm
I63	147 Nm	63 mm	0.37 ÷ 1.8 kW	ø25 mm	ø28 ø30 mm
I85	347 Nm	85 mm	0.55 ÷ 4.0 kW	ø35 mm	-
I11	651 Nm	110 mm	1.1 ÷ 4.0 kW	ø42 mm	-
411I	38 Nm	38 mm	0.37 ÷ 1.5 kW	ø19 mm	-

THE BEST PROTECTION IN 304

Housing

Strong and modular square housing.

Cassa con forma quadrata robusta e modulare.

Viton seals

Single viton seal for harsh environment.

Anelli di tenuta in viton per ambienti aggressivi.



Options Twin viton seals

Twin viton seals with stainless steel 316L shield for IP69k protection.

Doppi anelli di tenuta in viton con schermo protettivo in acciaio inox AISI 316L per protezione IP69k.



Hardened and ground worm

Hardened and ground worm, teeth radiused for noise reduction.

La vite senza fine è temprata ed i denti sono profilati e raggiati per ridurre il rumore.



Options Coupling

Premium input coupling with direct mounting
No settings - No screw.

*Giunto in entrata:
Montaggio diretto - No settaggi - No viti.*



Output hollow shaft

Stainless steel hollow shaft in AISI 316L.

CuSn12Ni (C91700) Nickel bronze for superior life.

*Mozzo in acciaio inox 316L.
Corona in bronzo al Nickel CuSn12Ni (C91700) centrifugato per massima resistenza e durata superiore.*



STRONG SQUARE DESIGN

Solida forma quadrata



Stainless steel hardware

Stainless steel output male shaft, protection cap, feet, screws and reaction arms.

Albero maschio in uscita removibile, coperchietto di protezione, piedi, viteria e bracci di reazione in AISI 316L.



INDEX

Section 1



Smooth surface aluminum worm gearboxes

Riduttori a vite senza fine in alluminio con superficie liscia

ALUMINUM

Section 2



Smooth surface aluminum ratio multipliers

Riduttori ad uno stadio in alluminio con superficie liscia

ALUMINUM

Section 3



Full stainless steel round worm gearboxes

Riduttori a vite senza fine tondo completamente in acciaio inox

AISI 316L

Section 4



Full stainless steel ratio multipliers

Riduttori ad uno stadio completamente in acciaio inox

AISI 316L

Section 5



Full stainless steel helical bevel gearboxes

Riduttori a coppia conica completamente in acciaio inox

AISI 316L

Section 6

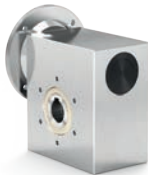

Full stainless steel square worm gearboxes

Riduttori a vite senza fine quadrati completamente in acciaio inox

AISI 304

Section 7



Full stainless steel ratio multipliers

Riduttori ad uno stadio completamente in acciaio inox

AISI 304

Section 8



How to select a product and useful formulas

Come selezionare un prodotto e formule utili

The starting base for avoiding dust accumulation

(Clean aluminum motors also available)

*La base di partenza per evitare l'accumulo di polvere
(disponibili anche con motori in alluminio)*

ALUMINUM

IP66

CE







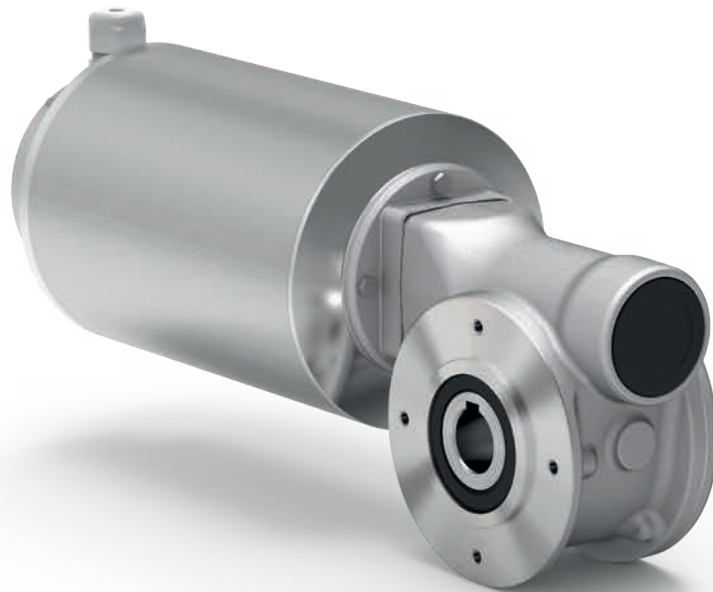









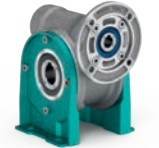

On req.
A rich.







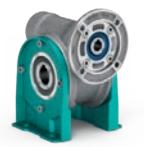









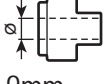

IP69k

Ex
ATEX

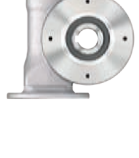

How to order Codifica

P	D45	UNI	N	10	0	MA	C
Type <i>Tipo</i>	Size <i>Grandezza</i>	Mounting <i>Montaggio</i>	Position <i>Posizione</i>	Ratio <i>Rapporto</i>	Hub Output shaft <i>Mozzo corona Albero uscita</i>	Diameter <i>Diametro</i>	Input / output shaft material <i>Materiale alberi in entrata e uscita</i>
P 	Worm gearboxes <i>Riduttori a vite senza fine</i>	UNI 	N 	See technical data table <i>Vedi tabelle dati tecnici</i>	0 Hollow <i>Mozzo</i> 	→ Standard D30 - 3D3 MA → ø14	C Cast iron / Carbon steel <i>Ghisa</i>
M 	D30 D45 D50 D63 D85	FLC 	 	Select L or R position for output flange <i>Selezionare la posizione L o R per la flangia in uscita</i>	S Solid output shaft <i>Albero in uscita</i> 	D45 - 4D3 MB → ø18 MC → ø19 MD → ø20	I Stainless steel (Output hollow shaft ø38 is not available in stainless steel) <i>(L'albero cavo ø38 non è disponibile in acciaio inox)</i>
B 		FLL 	Select L or R position for output flange <i>Selezionare la posizione L o R per la flangia in uscita</i>			D50 - 5D3 ME → ø24 MF → ø25	
R 	Combined worm gearboxes not available for type B <i>Riduttori a vite senza fine combinati non disponibili per tipo B</i>	BRI Stainless steel <i>Acciaio inox</i> BRZ Zinc plated <i>Zincato</i> 	L Left <i>Sinistra</i> 	R Right <i>Destra</i> 	D63 - 6D3 6D4 MF → ø25 MG → ø28 MH → ø30	Output male shaft is available only for standard bore <i>Albero maschio in uscita è disponibile solo per fori standard</i>	
	PAI Stainless steel <i>Acciaio inox</i> PAB Zinc plated <i>Zincato</i> 	PVI Stainless steel <i>Acciaio inox</i> PVB Zinc plated <i>Zincato</i> 	D85 - 8D4 MK → ø35 ML → ø38				
	3D3 4D3 5D3 6D3 6D4 8D4	PBB Zinc plated <i>Zincato</i> 					

N	C	-R	B3	ST	A	---	For M type specify terminal box position <i>Per tipo M specificare posizione morsettera</i>
Protection cap <i>Coperchio di protezione</i>		Motor size <i>Grandezza motore</i>	Mounting position <i>Posizione di montaggio</i>	Input bore <i>Foro entrata</i>	Coating <i>Trattamento</i>	Mounting position <i>Posizione di montaggio</i>	
Left <i>Sinistra</i>	Right <i>Destra</i>	Motor flanges <i>Flange motore</i>	B3	ST Standard bore * Kit R standard <i>Foro standard * Kit R standard</i>	A Standard in aluminum <i>Standard in alluminio</i>	Only for combined units See technical data table <i>Solo per i riduttori combinati Vedi tabelle dati tecnici.</i>	A
				Input bore without reduction bushing			B
N Without protection cap <i>Senza coperchietto di protezione</i>	N Without protection cap <i>Senza coperchietto di protezione</i>	IEC B5 -A → 56 B5 (ø120) -B → 63 B5 (ø140) -C → 71 B5 (ø160) -D → 80 B5 (ø200) -E → 90 B5 (ø200) -F → 100-112B5 (ø250)	B8 	-O → 9mm -P → 11mm -Q → 14mm -R → 19mm -T → 24mm -U → 28mm	N NTT coating <i>NTT Rivestimento</i>		C
		IEC B14 -O → 56 B14 (ø80) -P → 63 B14 (ø90) -Q → 71 B14 (ø105) -R → 80 B14 (ø120) -T → 90 B14 (ø140) -U → 100-112B14 (ø160)	B6 	Coupling Standard (IEC)  -A → 9mm -B → 11mm -C → 14mm -D → 19mm -E → 24mm -F → 28mm	Not available for combined gearboxes <i>Non disponibile per riduttori combinati</i>		D
C Closed <i>Chiuso</i>	C Closed <i>Chiuso</i>	BRUSHLESS BA → 40/63-M5 BB → 50/70-M5 BC → 60/75-M5 BD → 70/90-M6 BE → 80/100-M6 BF → 95/115-M8 BG → 110/145-M8 BH → 130/165-M8	B7 	Brushless *  -1 → 9mm -2 → 11mm -3 → 14mm -4 → 19mm -5 → 22mm -6 → 24mm	V Painted <i>Verniciato</i>		
		Brushless-Tech catalogue is available in our website <i>Catalogo Brushless-Tech è disponibile nel nostro sito web</i>	V5 	Ready for input coupling <i>Predisposto per giunto</i>	Ral 7035 		
		Without flange <i>Senza flangia</i> -M → Metric 	V6 	-0 Type B <i>Tipo B</i>  -0 Type R <i>Tipo R</i> 			
		Type R <i>Tipo R</i> -0 → Metric 		* With reduction bushing where applicable <i>* Con bussola di riduzione dove prevista</i>			

Input speed (n_1) = 1400 min⁻¹

Output speed n_2 [min ⁻¹]	Ratio i	Motor power P_{1M} [kW]	Output torque M_{2M} [Nm]	Service factor $f.s$	Nominal power P_{1R} [kW]	Nominal torque M_{2R} [Nm]	B5 motor flanges		B14 motor flanges		Dynamic efficiency RD	Tooth module [mm]	Ratio code
							-A 56	-B 63	-O 56	-P 63			
280	5	0.18	5	3.3	0.60	17	B		B-C		82	1.26	09
200	7	0.18	7	2.4	0.44	17	B		B-C		80	1.44	01
140	10	0.18	10	1.8	0.32	17	B		B-C		78	1.44	02
93	15	0.18	13	1.4	0.25	19	B		B-C		73	1.44	03
70	20	0.18	17	1.1	0.20	19	B		B-C		70	1.09	04
47	30	0.12	15	1.4	0.17	21	B		B-C		62	1.44	05
35	40	0.12	19	1.1	0.13	20	B		B-C		57	1.09	06
23	61	0.09	19	1.1	0.10	20	B		B-C		50	0.72	07
17.5	80	0.06	16	1.0	0.06	16	B		B-C		48	0.56	08
14	100	0.06*	16	0.5	0.03	8	B		B-C		40	0.45	10

* Power higher than the maximum one which can be supported by the gearbox. Select according to the torque M_{2R}

Potenza superiore a quella massima sopportabile dal riduttore. Selezionare in base al momento torcente M_{2R}

Motor flanges available
Flange motore disponibili



B) Supplied with reduction bushing
Fornito con bussola di riduzione



B) Available on request without reduction bushing
Disponibile a richiesta senza bussola di riduzione



C) Motor flange holes position
Posizione fori flangia motore

Lubrication

Lubrificazione

Unit D30 is supplied with synthetic oil to assure long life lubrication. Food grade oil is available on request.

See Table 1 for lubrication and recommended quantity.

See Table 2 for possible radial and axial loads on the gearbox.

Il riduttore tipo D30 viene fornito con olio sintetico e lubrificazione tipo "long life".

Disponibile a richiesta olio alimentare.

Vedi Tabella 1 per oli e quantità consigliati.

Vedi Tabella 2 per i carichi radiali e assiali applicabili al riduttore.

Oil quantity for all positions:
0.03 L

Quantità olio per tutte le posizioni: 0.03 L

Shell
Omala S4 WE 320

Eni
Telium VSF 320

Tab. 1

Suggested

Suggerito

Stainless steel protection cap (on request).

Coperchio di protezione in acciaio inox a richiesta.

Kit cod. KN300209

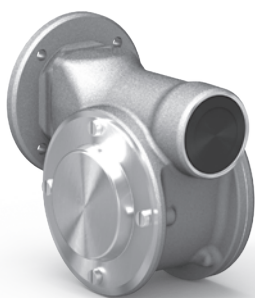

Radial and axial loads

Carichi radiali e assiali

Output shaft

Albero di uscita

n_2 [min ⁻¹]	F_A [N]	F_R [N]
200	120	600
150	140	700
100	160	800
75	180	900
50	200	1000
25	250	1250
15	280	1400

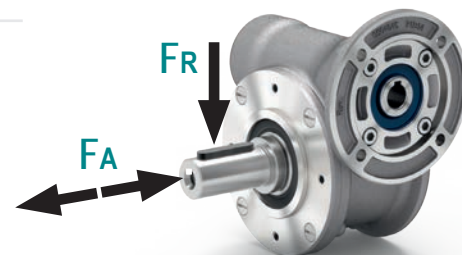

Input shaft

Albero in entrata

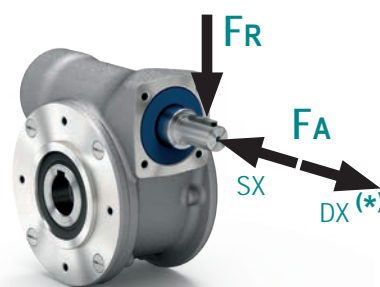

n_1 [min ⁻¹]	F_A [N]	F_R [N]
1400	20	100

* Strong axial loads in the DX direction are not allowed.

* Non sono consentiti forti carichi assiali con direzione DX

Tab. 2

PD30UNI.. Basic gearbox
Riduttore base

Gearbox weight
Peso riduttore **1.05 kg**

M. flanges	Kit code	øF	A
56B5	KD304041	120	62
63B5	KD304042	140	63
56B14	KD304046	80	62
63B14	KD304045	90	63

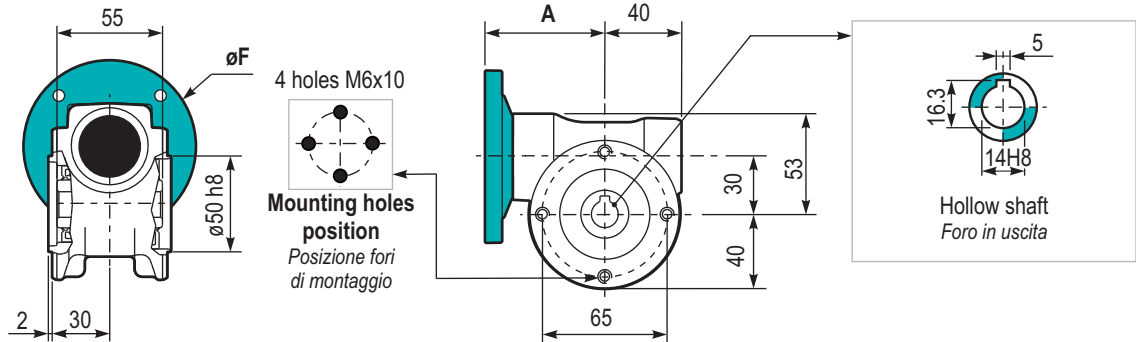

PD30PA... Feet
Piedini

Type	T	Kit code
B**	87	K0309022
I*	80	KN309022

** Zink plated
* Stainless steel

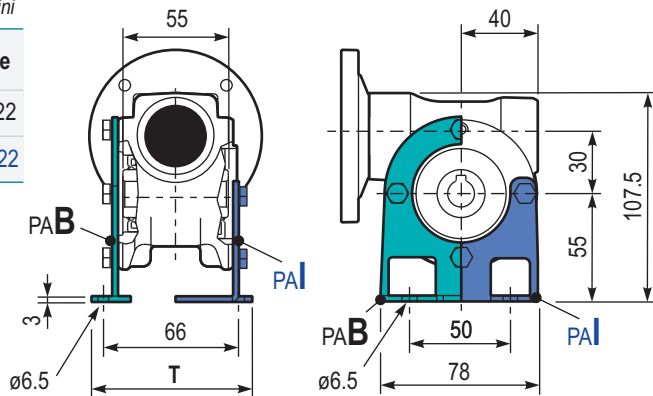

PD30PBB.. Feet
Piedini

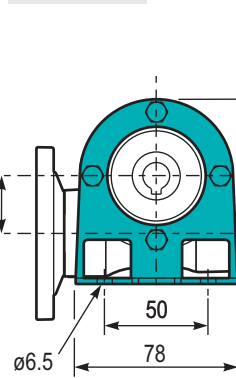

PD30PV... Feet
Piedini

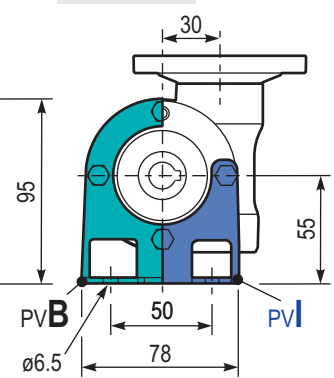

PD30FL.. Output flange
Flangia uscita

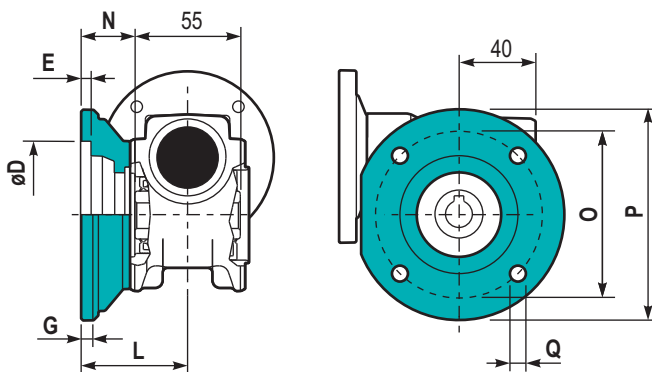

PD30BR... Reaction arm
Braccio di reazione

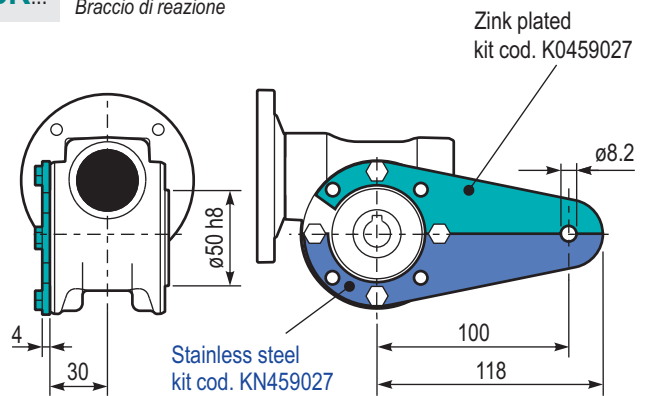

Type	øD	E	G	L	N	O	P	Q	Kit code
C	50 ^{+0.15} / _{+0.05}	6	6	50.5	23	68	80	7	K0309010
L	60 ^{+0.15} / _{+0.05}	6	6	55.5	28	87	110	8.5	K0459010

RD30UNI.. Input shaft
Albero in entrata

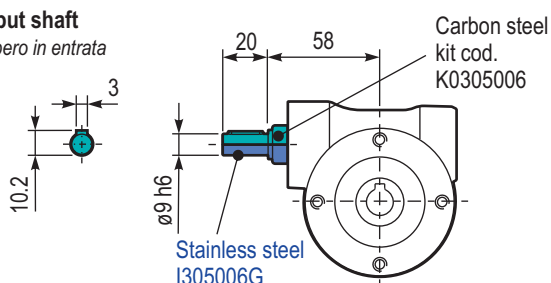

PD30..SMA Single output shaft
Albero semplice in uscita

kit cod. KN300209
Protection cap
(on request)
A richiesta coperchio di protezione

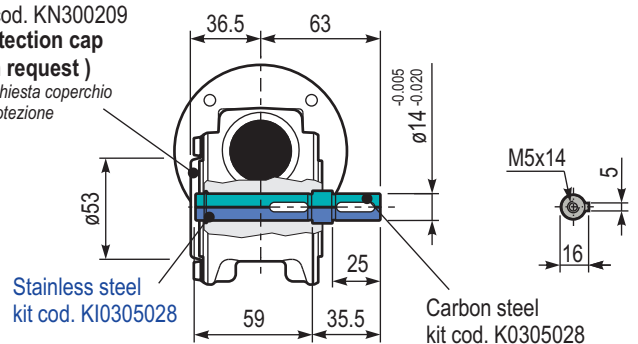

Input speed (n_1) = 1400 min⁻¹

Output speed n_2 [min ⁻¹]	Ratio i	Motor power P_{1M} [kW]	Output torque M_{2M} [Nm]	Service factor $f.s$	Nominal power P_{1R} [kW]	Nominal torque M_{2R} [Nm]	B5 motor flanges			B14 motor flanges			Dynamic efficiency RD	Tooth module [mm]	Ratio code
							-B 63	-C 71		-O 56	-P 63	-Q 71			
200	7	0.37	14	2.2	0.80	30	B			B-C	B-C		80	2.2	01
140	10	0.37	20	1.5	0.57	30	B			B-C	B-C		79	2.2	02
100	14	0.37	27	1.1	0.41	30	B			B-C	B-C		77	2.4	03
67	21	0.37	36	1.2	0.43	41	B			B-C	B-C		67	1.6	04
50	28	0.25	31	1.3	0.33	41	B			B-C	B-C		65	2.5	05
38	37	0.25	40	1.0	0.26	41	B			B-C	B-C		63	1.8	06
30	46	0.25	46	0.9	0.22	41	B			B-C	B-C		59	1.5	07
23	60	0.18	41	1.0	0.18	41	B			B-C	B-C		56	1.2	08
20	70	0.12	31	1.0	0.12	30	B			B-C	B-C		54	1.0	09
13.7	102	0.09	31	1.0	0.09	29	B			B-C	B-C		49	0.72	10

Motor flanges available
Flange motore disponibili

B) Supplied with reduction bushing
Fornito con bussola di riduzione

B) Available on request without reduction bushing
Disponibile a richiesta senza bussola di riduzione

C) Motor flange holes position
Posizione fori flangia motore

Lubrication

Lubrificazione

Unit D45 is supplied with synthetic oil to assure long life lubrication. Food grade oil is available on request.

See Table 1 for lubrication and recommended quantity.

See Table 2 for possible radial and axial loads on the gearbox.

Il riduttore tipo D45 viene fornito con olio sintetico e lubrificazione tipo "long life".

Disponibile a richiesta olio alimentare.

Vedi Tabella 1 per oli e quantità consigliati.

Vedi Tabella 2 per i carichi radiali e assiali applicabili al riduttore.

Oil quantity for all positions:
0.09 L

Quantità olio per tutte le posizioni: 0.09 L

Shell
Omala S4 WE 320

Eni
Telium VSF 320

Tab. 1

Suggested

Suggerito

Stainless steel protection cap (on request).

Coperchio di protezione in acciaio inox a richiesta.

Kit cod. KN300209

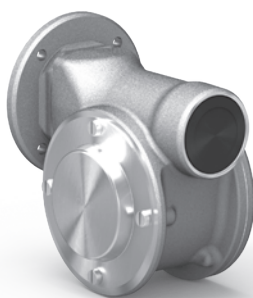

Radial and axial loads

Carichi radiali e assiali

Output shaft

Albero di uscita

n_2 [min ⁻¹]	F_A [N]	F_R [N]
200	180	900
150	200	1000
100	220	1100
75	240	1200
50	260	1400
25	300	1800
15	400	2000

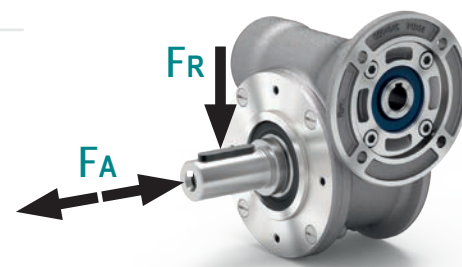

Input shaft

Albero in entrata

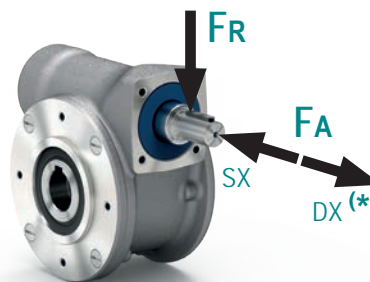

n_1 [min ⁻¹]	F_A [N]	F_R [N]
1400	42	210

* Strong axial loads in the DX direction are not allowed.

* Non sono consentiti forti carichi assiali con direzione DX

Tab. 2

PD45**UNI**.. Basic gearbox
Riduttore base

M. flanges	Kit code	øF	A
63B5	KD454041	138	74
71B5	KD454042	160	71.5
56B14	KD454049	80	71.5
63B14	KD454047	90	74
71B14	KD454045	105	71.5

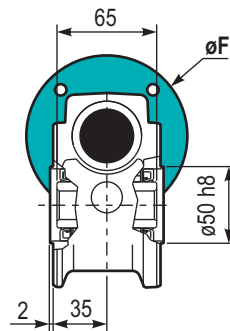

4 holes M6x14
Mounting holes position
Posizione fori di montaggio

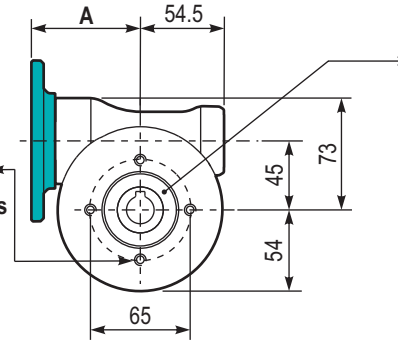

Gearbox weight
Peso riduttore 2.40 kg

Hollow shaft
Foro in uscita

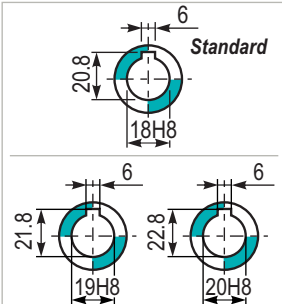

PD45**PA**... Feet
Piedini

Type	T	Kit code
B**	102	K0459022
I*	100	KN459022

** Zink plated
* Stainless steel

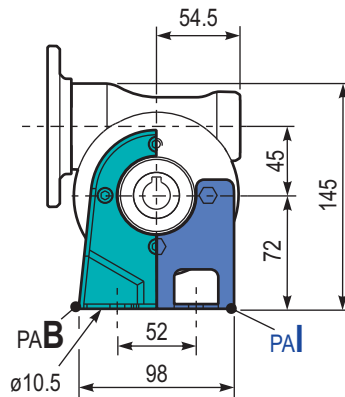
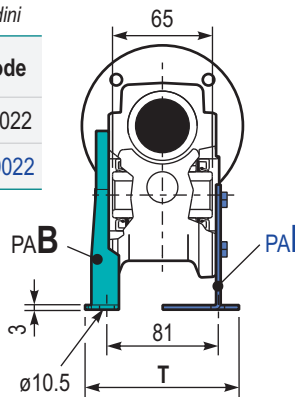

PD45**PBB**.. Feet
Piedini

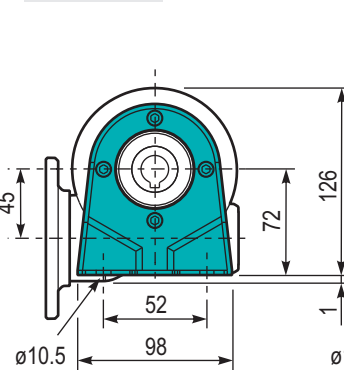

PD45**PV**... Feet
Piedini

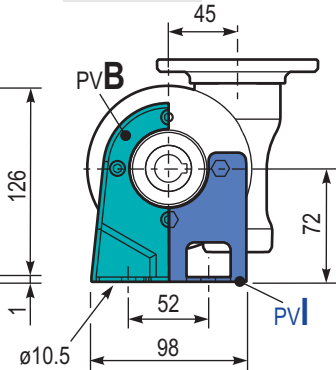

PD45**FL**.. Output flange
Flangia uscita

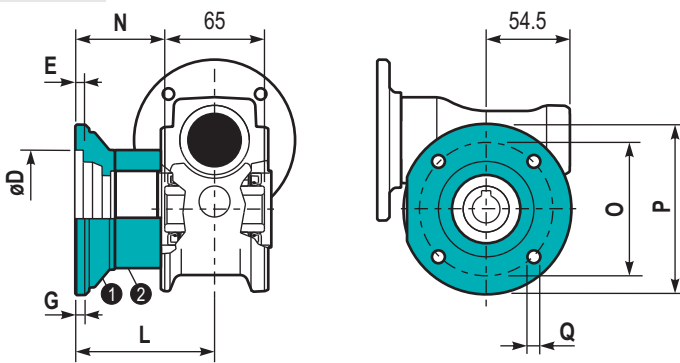

Type	øD	E	G	L	N	O	P	Q	Kit code
C	60 ^{+0.15} / _{+0.05}	9	9	60.5	28	87	110	8.5	① K0459010 ② -
L	60 ^{+0.15} / _{+0.05}	9	9	90.5	58	87	110	8.5	① K0459010 ② K0450200

PD45**BR**... Reaction arm
Braccio di reazione

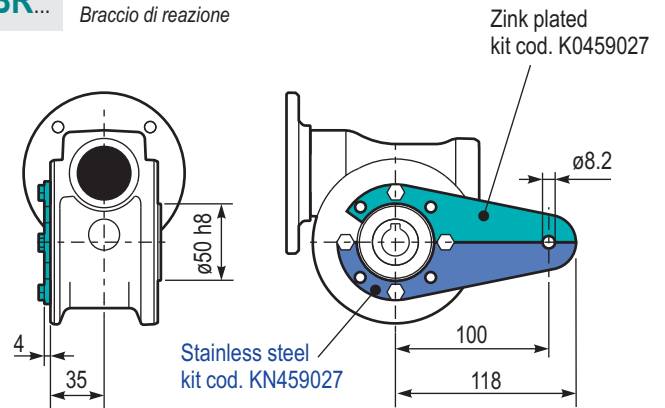

RD45**UNI**..

Input shaft
Albero in entrata

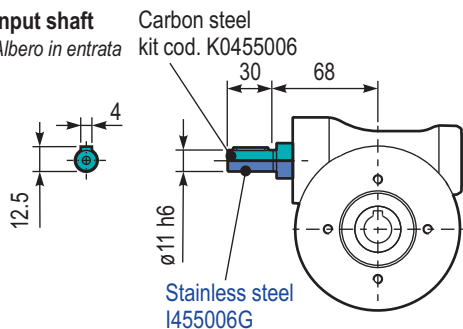

PD45..**SMB** Single output shaft
Albero semplice in uscita

kit cod. KN300209
Protection cap
(on request)
A richiesta coperchio di protezione

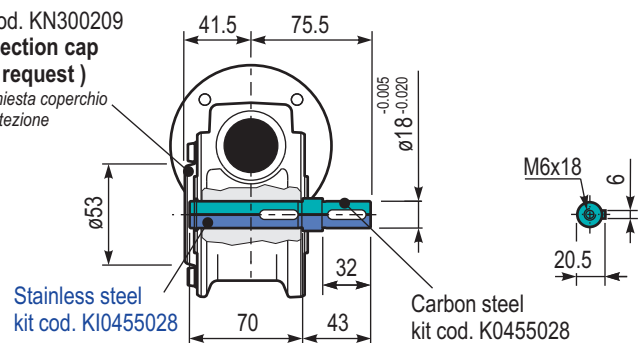

Input speed (n_1) = 1400 min⁻¹

Output speed n_2 [min ⁻¹]	Ratio i	Motor power P_{1M} [kW]	Output torque M_{2M} [Nm]	Service factor $f.s$	Nominal power P_{1R} [kW]	Nominal torque M_{2R} [Nm]	B5 motor flanges				B14 motor flanges				Dynamic efficiency RD	Tooth module [mm]	Ratio code
							-B 63	-C 71	-D 80	-O 56	-P 63	-Q 71	-R 80				
200	7	0.75	29	1.9	1.5	57	B	B			B-C	B		82	2.5	01	
140	10	0.75	41	1.5	1.1	62	B	B			B-C	B		80	2.4	02	
100	14	0.75	57	1.2	0.90	68	B	B			B-C	B		79	2.6	03	
78	18	0.55	51	1.2	0.67	62	B	B			B-C	B		75	2.0	04	
54	26	0.55	67	1.0	0.54	66	B	B			B-C	B		69	2.7	05	
47	30	0.55	79	0.9	0.50	72	B	B			B-C	B		70	2.5	12	
39	36	0.37	63	1.2	0.43	72	B				B-C	B-C		69	2.1	06	
33	43	0.37	72	1.0	0.35	68	B				B-C	B-C		66	1.8	07	
28	50	0.25	53	1.2	0.31	66	B				B-C	B-C		62	1.5	13	
23	60	0.25	59	1.0	0.26	62	B				B-C	B-C		58	1.3	08	
21	68	0.25	66	0.9	0.22	58	B				B-C	B-C		57	1.2	09	
17.5	80	0.18	53	1.1	0.19	57	B				B-C	B-C		54	1.0	10	
14	100	0.12	41	1.3	0.15	51	B				B-C	B-C		50	0.8	11	

Motor flanges available
Flange motore disponibili



B) Supplied with reduction bushing
Fornito con bussola di riduzione



B) Available on request without reduction bushing
Disponibile a richiesta senza bussola di riduzione



C) Motor flange holes position
Posizione fori flangia motore

Lubrication

Lubrificazione

Unit D50 is supplied with synthetic oil to assure long life lubrication. Food grade oil is available on request. See Table 1 for lubrication and recommended quantity. See Table 2 for possible radial and axial loads on the gearbox.

Il riduttore tipo D50 viene fornito con olio sintetico e lubrificazione tipo "long life". Disponibile a richiesta olio alimentare. Vedi Tabella 1 per oli e quantità consigliati. Vedi Tabella 2 per i carichi radiali e assiali applicabili al riduttore.

Oil quantity for all positions:
0.14 L

Quantità olio per tutte le posizioni: 0.14 L

Shell
Omala S4 WE 320

Eni
Telium VSF 320

Tab. 1

Suggested

Suggerito

Stainless steel protection cap (on request).

Coperchio di protezione in acciaio inox a richiesta.

Kit cod. KN500209

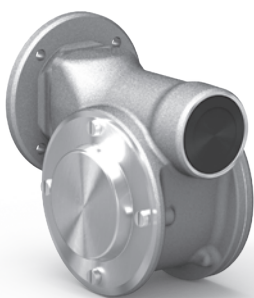

Radial and axial loads

Carichi radiali e assiali

Output shaft

Albero di uscita

n_2 [min ⁻¹]	FA [N]	FR [N]
200	240	1200
150	280	1400
100	300	1500
75	340	1700
50	380	1900
25	480	2500
15	560	2800

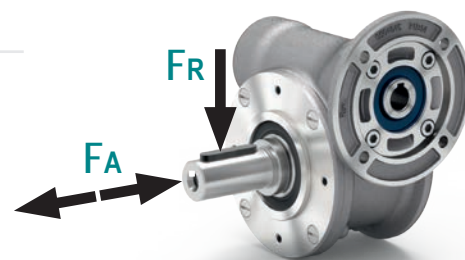

Input shaft

Albero in entrata

n_1 [min ⁻¹]	FA [N]	FR [N]
1400	76	380

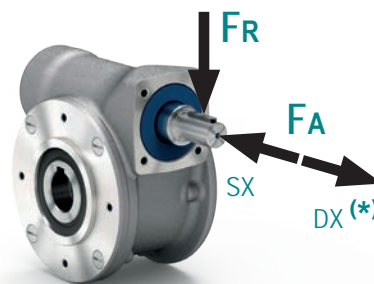

* Strong axial loads in the DX direction are not allowed.
* Non sono consentiti forti carichi assiali con direzione DX

Tab. 2

PD50 **UNI..** Basic gearbox
Riduttore base

M. flanges	Kit code	øF	A
63B5	KD504041	138	78.5
71B5	KD504042	160	76
80B5	KD504043	200	76.5
56B14	KD504049	80	76
63B14	KD504047	90	78.5
71B14	KD504045	105	76
80B14	KD504046	120	76.5

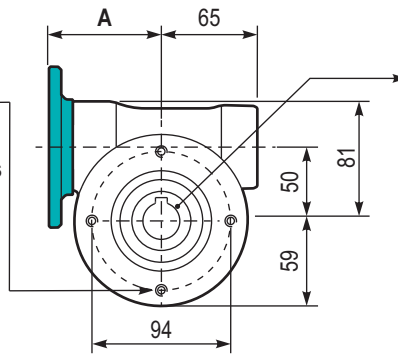
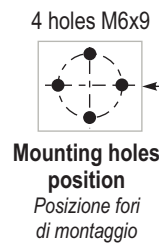
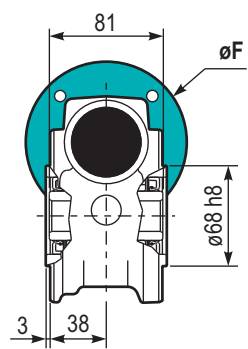

Gearbox weight
Peso riduttore **3.00 kg**

Hollow shaft
Foro in uscita

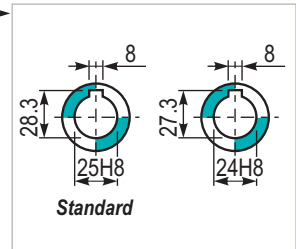

PD50 **PA...** Feet
Piedini

Type	T	Kit code
B**	123	K0509022
I*	122	KN509022

** Zink plated
* Stainless steel

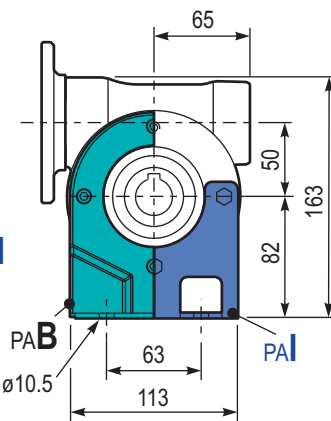
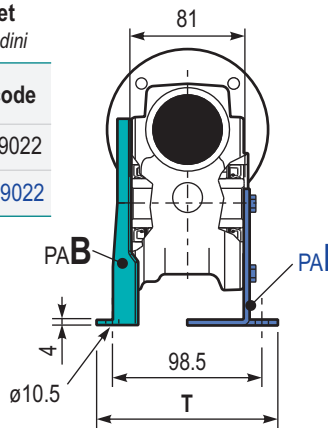

PD50 **PBB..** Feet
Piedini

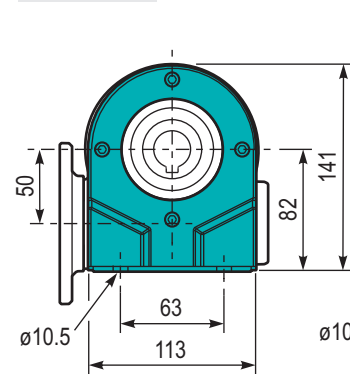

PD50 **PV...** Feet
Piedini

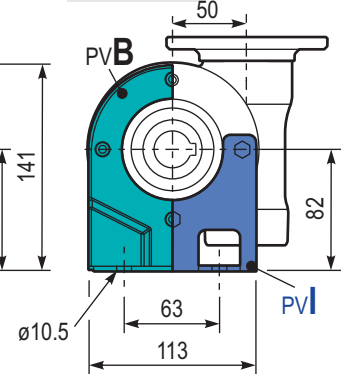

PD50 **FL..** Output flange
Flangia uscita

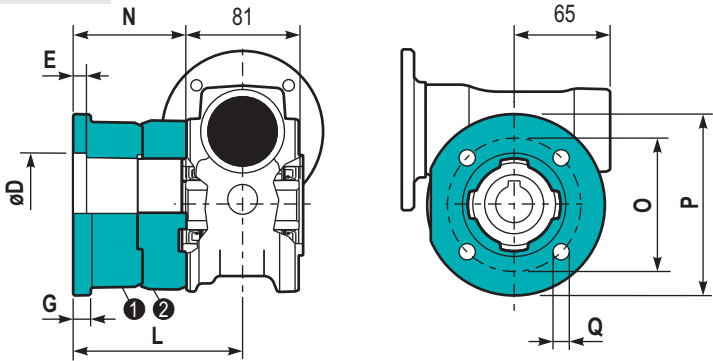

Type	øD	E	G	L	N	O	P	Q	Kit code
C	70 ^{+0.20} / _{+0.15}	9	12	85	44.5	90	123	10.5	① K0509010 ② -
L	70 ^{+0.20} / _{+0.15}	9	12	114.5	74	90	123	10.5	① K0509010 ② K0500200

PD50 **BR...** Reaction arm
Braccio di reazione

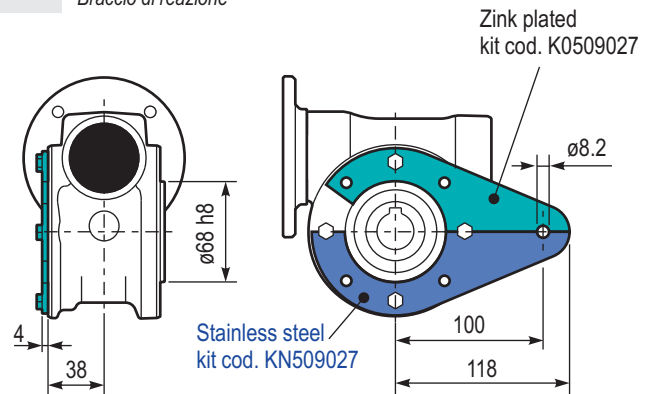

RD50UNI.. Input shaft
Albero in entrata

Carbon steel kit cod. K0505006 PAM71
Carbon steel kit cod. K0505007 PAM80

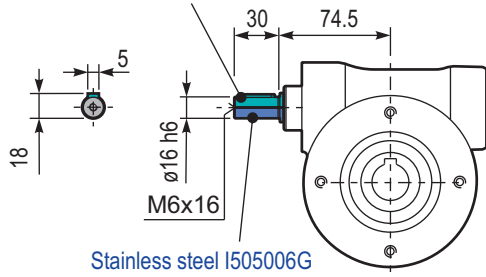

PD50 **SMF** Single output shaft
Albero semplice in uscita

kit cod. KN500209
Protection cap (on request)
A richiesta coperchio di protezione

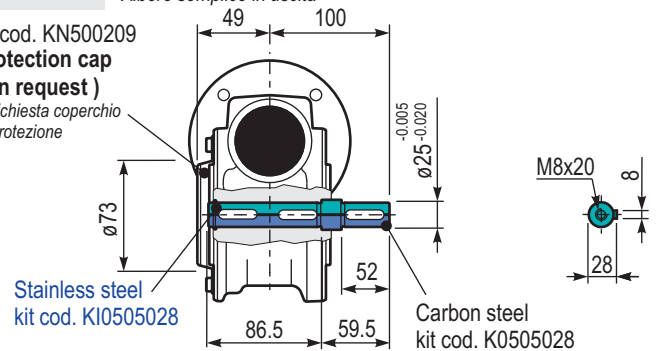

Input speed (n_1) = 1400 min⁻¹

Output speed n_2 [min ⁻¹]	Ratio i	Motor power P_{1M} [kW]	Output torque M_{2M} [Nm]	Service factor $f.s$	Nominal power P_{1R} [kW]	Nominal torque M_{2R} [Nm]	B5 motor flanges				B14 motor flanges			Dynamic efficiency RD	Tooth module [mm]	Ratio code	
							-B 63	-C 71	-D 80	-E 90	-Q 71	-R 80	-T 90				
200	7	1.8	71	1.8	3.2	125		B	B			B-C	B-C		83	3.1	01
140	10	1.8	99	1.4	2.4	134		B	B			B-C	B-C		81	3.1	02
93	15	1.5	121	1.1	1.7	138		B	B			B-C	B-C		79	3.1	03
74	19	1.1	111	1.2	1.4	138		B	B			B-C	B-C		78	2.6	04
58	24	1.1	135	1.0	1.2	142		B	B			B-C	B-C		75	2.0	05
47	30	1.1	167	0.9	0.96	146		B	B			B-C	B-C		74	3.2	06
39	36	0.75	125	1.2	0.88	147		B	B			B-C	B-C		68	2.7	07
35	40	0.75	135	1.0	0.78	140		B	B	B		B-C	B-C		66	2.5	13
31	45	0.55	111	1.2	0.67	135	B	B				B-C	C		66	2.1	08
23	60	0.55	140	0.9	0.51	130	B	B				B-C	C		62	1.6	12
21	67	0.55	151	0.8	0.45	124	B	B				B-C	C		60	1.5	09
17.5	80	0.37	115	1.0	0.38	119	B	B				B-C	C		57	1.3	10
14.9	94	0.37	123	1.0	0.36	119	B	B				B-C	C		52	1.1	11

Motor flanges available
Flange motore disponibili



B) Supplied with reduction bushing
Fornito con bussola di riduzione



B) Available on request without reduction bushing
Disponibile a richiesta senza bussola di riduzione



C) Motor flange holes position
Posizione fori flangia motore

Lubrication

Lubrificazione

Unit D63 is supplied with synthetic oil to assure long life lubrication. Food grade oil is available on request.

See Table 1 for lubrication and recommended quantity.

See Table 2 for possible radial and axial loads on the gearbox.

Il riduttore tipo D63 viene fornito con olio sintetico e lubrificazione tipo "long life". Disponibile a richiesta olio alimentare.

Vedi Tabella 1 per oli e quantità consigliati.

Vedi Tabella 2 per i carichi radiali e assiali applicabili al riduttore.

Oil quantity for all positions: 0.40 L	Shell Omala S4 WE 320	Eni Telium VSF 320
Quantità olio per tutte le posizioni: 0.40 L		

Tab. 1

Suggested

Suggerito

Stainless steel protection cap (on request).

Coperchio di protezione in acciaio inox a richiesta.

Kit cod. KN630209

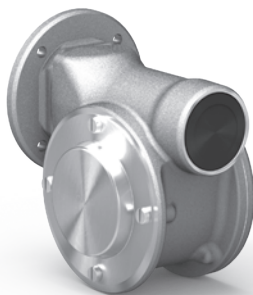

Radial and axial loads

Carichi radiali e assiali

Output shaft

Albero di uscita

n_2 [min ⁻¹]	FA [N]	FR [N]
200	360	1800
150	400	2000
100	460	2300
75	500	2500
50	600	3000
25	700	3800
15	800	4000

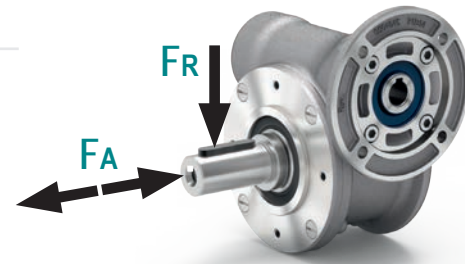

Input shaft

Albero in entrata

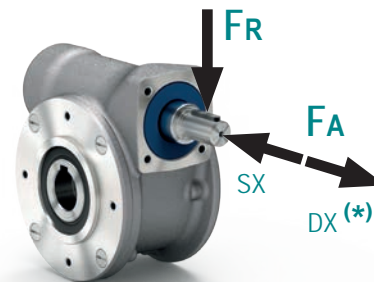

n_1 [min ⁻¹]	FA [N]	FR [N]
1400	90	450

* Strong axial loads in the DX direction are not allowed.

* Non sono consentiti forti carichi assiali con direzione DX

Tab. 2

PD63 **UNI..** Basic gearbox
Riduttore base

M. flanges	Kit code	øF	A
63B5	KD634041	140	99.5
71B5	KD634042	160	97.5
80/90B5	KD634043	200	99.5
71B14	KD634047	105	97.5
80B14	KD634046	120	99.5
90B14	KD634041	140	99.5

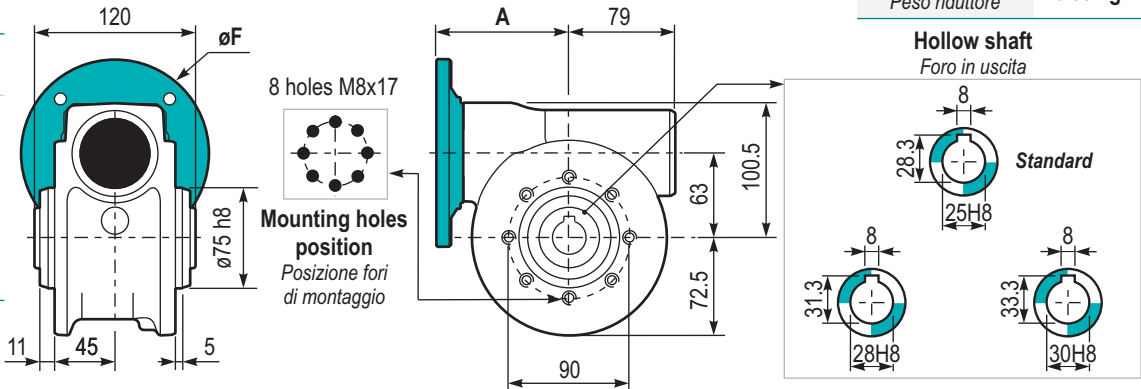

Gearbox weight
Peso riduttore 6.00 kg

Hollow shaft
Foro in uscita

PD63 **PA..** Feet
Piedini

Type	T	Kit code
B**	144	K0639022
I*	130	KN639022

** Zink plated
* Stainless steel

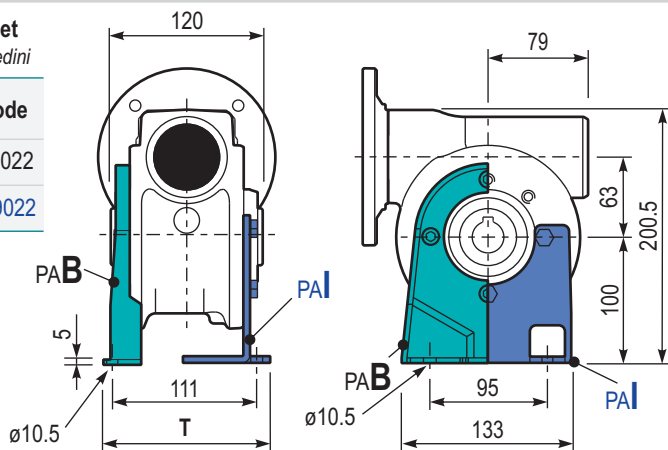

PD63 **PBB..** Feet
Piedini

PD63 **PV..** Feet
Piedini

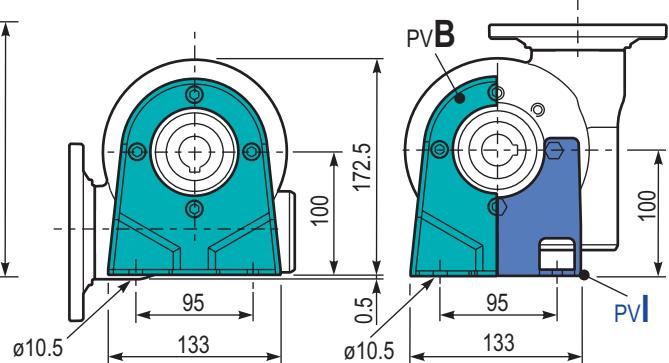

PD63 **FL..** Output flange
Flangia uscita

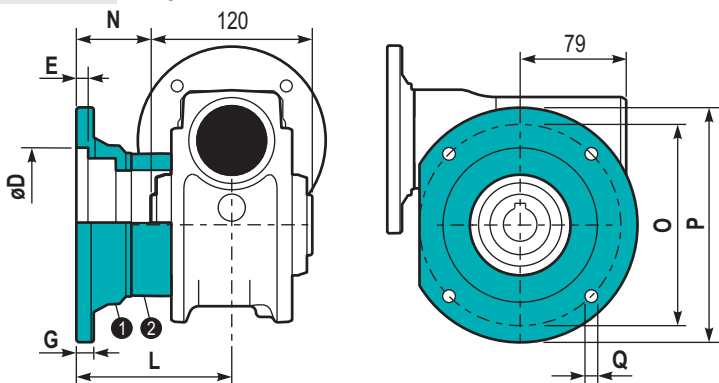

Type	øD	E	G	L	N	O	P	Q	Kit code
C	115 ^{+0.20} _{-0.15}	7	13	86	26	150	175	11	① K0639010 ② -
L	115 ^{+0.20} _{-0.15}	7	13	116	56	150	175	11	① K0639010 ② K0630200

PD63 **BR..** Reaction arm
Braccio di reazione

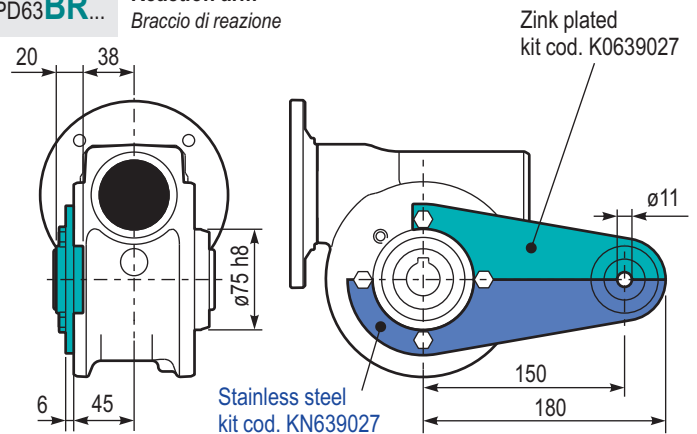

RD63 **UNI..** Input shaft
Albero in entrata

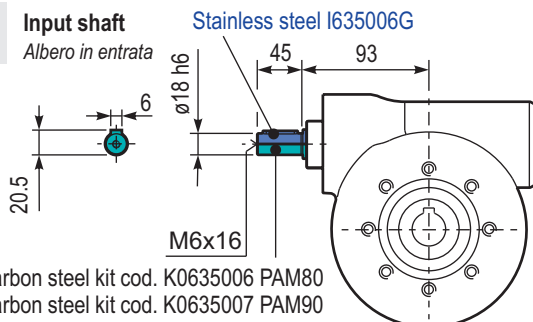

PD63 **SMF** Single output shaft
Albero semplice in uscita

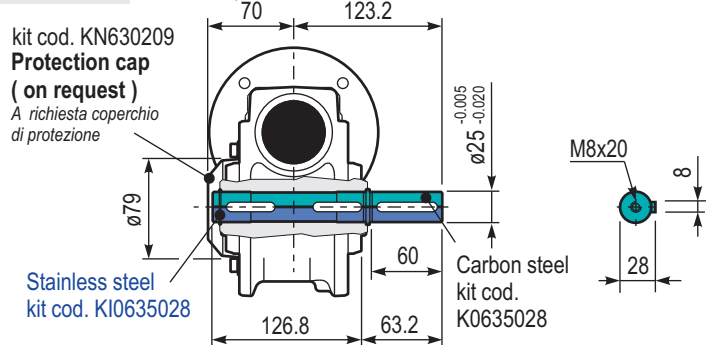

Input speed (n_1) = 1400 min⁻¹

Output speed n_2 [min ⁻¹]	Ratio i	Motor power P_{1M} [kW]	Output torque M_{2M} [Nm]	Service factor $f.s$	Nominal power P_{1R} [kW]	Nominal torque M_{2R} [Nm]	B5 motor flanges				B14 motor flanges			Dynamic efficiency RD	Tooth module [mm]	Ratio code
							-C 71	-D 80	-E 90	-F 100 112	-R 80	-T 90	-U 100 112			
200	7	4.0	168	1.5	6.1	257		B	B		B	B		88	4.23	01
140	10	4.0	218	1.3	5.2	284		B	B		B	B		80	4.2	02
100	14	3.0	223	1.4	4.1	305		B	B		B	B		78	4.5	03
70	20	2.2	237	1.2	2.7	294		B	B		B	B		79	3.4	04
64	22	2.2	258	1.1	2.5	294		B	B		B	B		78	3.1	05
50	28	2.2	315	1.1	2.4	347		B	B		B	B		75	4.7	06
37	38	1.5	276	1.2	1.8	336	B	B			B			71	3.5	07
30	46	1.5	320	1.0	1.5	326	B	B			B			68	3.1	08
27	52	1.1	258	1.1	1.2	289	B	B			B			66	2.7	09
21	67	1.1	327	0.9	0.97	289	B	B			B			65	2.1	10
18.9	74	0.75	220	1.2	0.91	268	B	B			B			58	1.9	11
14.6	96	0.55	191	1.3	0.70	242	B	B			B			53	1.5	12

Motor flanges available
Flange motore disponibili



B) Supplied with reduction bushing
Fornito con bussola di riduzione



B) Available on request without reduction bushing
Disponibile a richiesta senza bussola di riduzione



C) Motor flange holes position
Posizione fori flangia motore

Lubrication

Lubrificazione

Unit D85 is supplied with synthetic oil to assure long life lubrication. Food grade oil is available on request. See Table 1 for lubrication and recommended quantity. See Table 2 for possible radial and axial loads on the gearbox.

Il riduttore tipo D85 viene fornito con olio sintetico e lubrificazione tipo "long life". Disponibile a richiesta olio alimentare. Vedi Tabella 1 per oli e quantità consigliati. Vedi Tabella 2 per i carichi radiali e assiali applicabili al riduttore.

Oil quantity for all positions: 1.20 L	Shell Omala S4 WE 320	Eni Telium VSF 320
Quantità olio per tutte le posizioni: 1.20 L		

Tab. 1

Suggested

Suggerito

Stainless steel protection cap (on request).

Coperchio di protezione in acciaio inox a richiesta.

Kit cod. KN850209

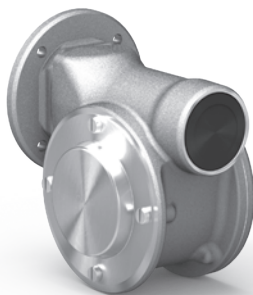

Radial and axial loads

Carichi radiali e assiali

Output shaft

Albero di uscita

n_2 [min ⁻¹]	FA [N]	FR [N]
200	500	2500
150	580	2900
100	600	3000
75	700	3500
50	800	4000
25	1000	5000
15	1160	5800

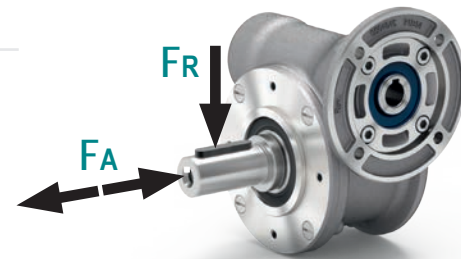

Input shaft

Albero in entrata

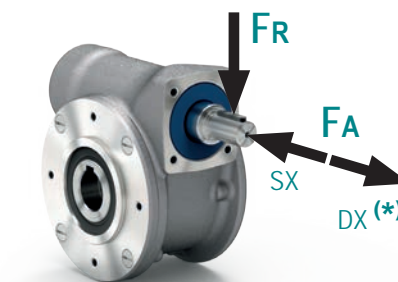

n_1 [min ⁻¹]	FA [N]	FR [N]
1400	130	650

* Strong axial loads in the DX direction are not allowed.

* Non sono consentiti forti carichi assiali con direzione DX

Tab. 2

PD85 **UNI..** Basic gearbox
Riduttore base

M. flanges	Kit code	øF	A
71B5	KD234041	160	116.5
80/90B65	KD234042	200	118.5
100/112B5	KD234043	250	127.5
80B14	KD854046	120	118.5
90B14	KD854045	140	118.5
100/112B14	KD854047	160	127.5

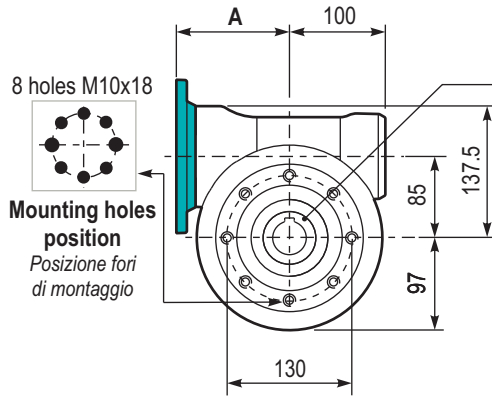
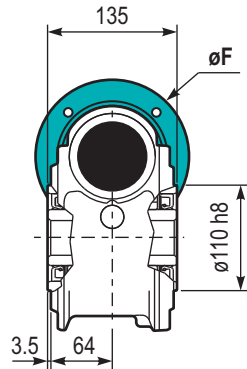

Gearbox weight
Peso riduttore 11.00 kg

Hollow shaft
Foro in uscita

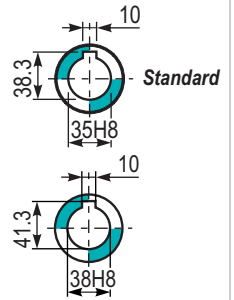

PD85 **PA...** Feet
Piedini

Type	T	V	Kit code
B**	182	180	K0859022
I*	176	172	KN859022

** Zink plated
* Stainless steel

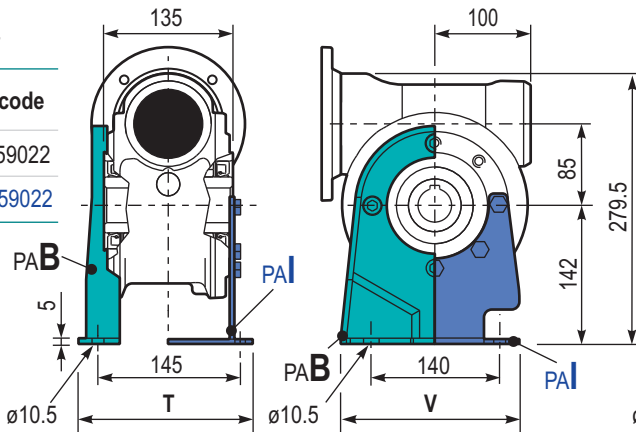

PD85 **PBB..** Feet
Piedini

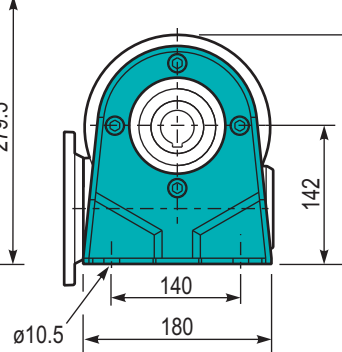

PD85 **PV...** Feet
Piedini

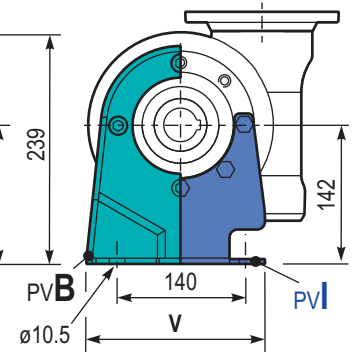

PD85 **FL..** Output flange
Flangia uscita

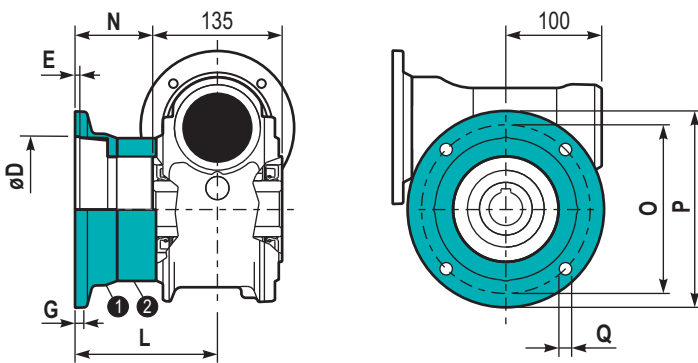

Type	øD	E	G	L	N	O	P	Q	Kit code
C	152 ^{+0.06} _{-0.00}	5	16	108	40.5	176	205	13	① K0859010 ② - ③ -
L	152 ^{+0.06} _{-0.00}	5	16	148.5	81	176	205	13	① K0859010 ② K0850201

PD85 **BR...** Reaction arm
Braccio di reazione

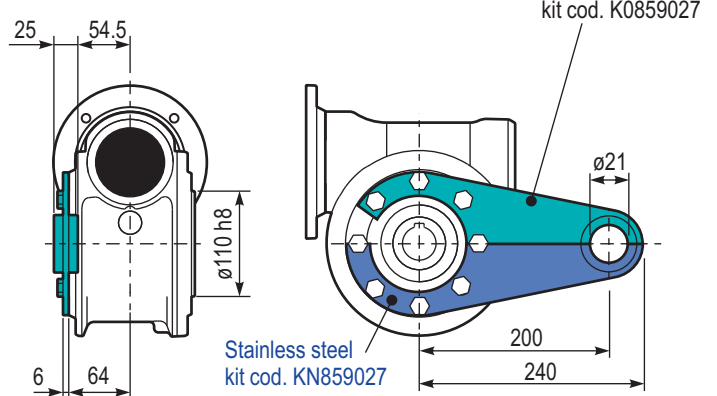

RD85 **UNI..** Input shaft
Albero in entrata

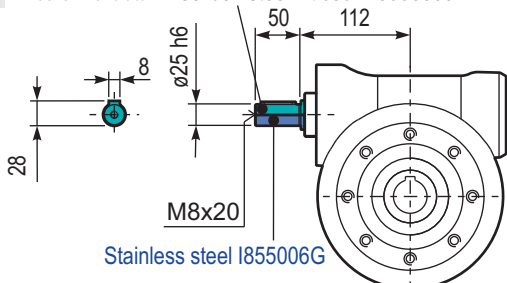

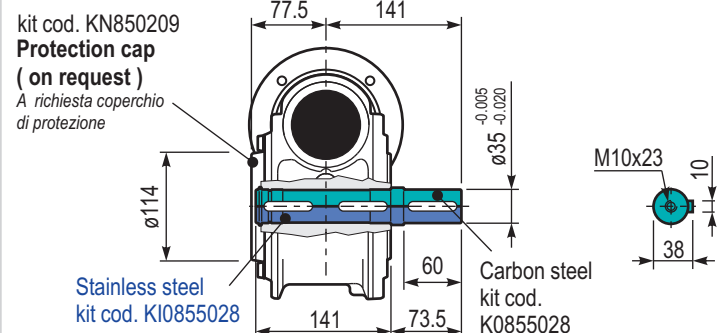

PD85 **SMK** Single output shaft
Albero semplice in uscita



D45 Ratios/Rating

Rapporti/Selezione D45

Ratio	Max output torque ** M_{2R} [Nm]	Tooth module  [mm]	Standard input bore	Ratio code 
i _a				
7	35	2.2	ø14	01
10	35	2.2	ø14	02
14	35	2.4	ø14	03
21	47	1.6	ø14	04
28	47	2.5	ø14	05
37	47	1.8	ø14	06
46	47	1.5	ø14	07
60	47	1.2	ø14	08
70	35	1.0	ø14	09
102	34	0.72	ø14	10

211D Ratios/Power

Rapporti/potenza 211D

Ratio	Max input power ** P_{1M} [kW]	Standard output shaft 	Ratios code
i _b			
2.05	0.37	ø14	01
2.35	0.37	ø14	02
2.80	0.37	ø14	03
3.38	0.37	ø14	04
4.70	0.37	ø14	05
6.22	0.37	ø14	06
8.29	0.37	ø14	07
9.83	0.25	ø14	08



211D Motor flanges

Flange motore 211D

	Kit code	g6	A
63B5	KD454041	138	99.5
71B5	KD454042	160	97
56B14	KD454049	80	97
63B14	KD454047	90	99.5
71B14	KD454045	105	97

How to connect D45+211D

Come collegare D45 + 211D

Worm gearbox		Ratio multiplier	Connection kit	
Standard input bore	Output shaft	With standard input bore	With coupling	
D45	øN	211D		
Ratios from 1/7 - 1/102	ø14	ø14	Reduction bushing is not necessary	KB14P

D45 weight
Peso D45

2.40 kg

211D weight
Peso 211D

1.40 kg

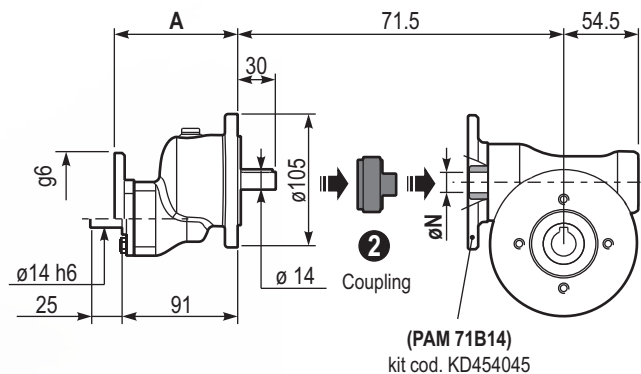
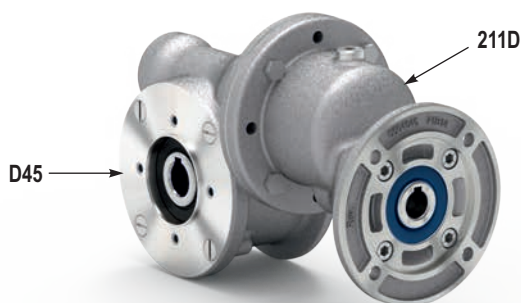

Ratios range: from 1/14 to 1/1003

Range rapporti: da 1/14 a 1/1003

Lubrication

Lubrificazione

Unit D45+211D is supplied with synthetic oil to assure long life lubrication. Food grade oil is available on request. See Table 1 for lubrication and recommended quantity.

Il riduttore tipo D45+211D viene fornito con olio sintetico e lubrificazione tipo "long life".

Disponibile a richiesta olio alimentare.

Vedi Tabella 1 per oli e quantità consigliati.

For all details on lubrication and plugs check our website.

Per maggiori dettagli su lubrificazione e tappi olio vedi il nostro sito web.

D45: 0.09 L	SHELL: Omala S4 WE 320	ENI: Telium VSF 320
211D: 0.05 L	SHELL: Omala S4 WE 320	ENI: Telium VSF 320

Calculate total ratio and output speed

Calcola il rapporto totale e la velocità di uscita

Ratios range: from 1/14 to 1/1003

Range rapporti: da 1/14 a 1/1003

$$i_{TOT} = i_a \cdot i_b$$

Ex.: 1/102 x 1/9.83 = 1/1003 (Max ratio)

Output speed (n₂)

Velocità di uscita

$$n_2 = n_1 : i_{TOT}$$

Ex.: 1448 : 1003 = 1.44 rpm

i_a : D45 ratio - Rapporto D45

i_b : 211D ratio - Rapporto 211D

** Make sure input power for 211D and output torque for D45 is as catalogue ratios.

** Prestare attenzione a selezionare la potenza in entrata del 211D ed il momento torcente del D45 secondo le tabelle del catalogo.

n₁ Input speed

Velocità di ingresso



VFD series with ratio multiplier RCD series

Riduttori a vite senza fine in alluminio con precoppia serie RCD

D50 211D

D50 Ratios/Rating

Rapporti/Selezione D50

Ratio	Max output torque ** M_{2R} [Nm]	Tooth module  [mm]	Standard input bore	Ratio code 
i _a				
7	65	2.5	∅19	01
10	71	2.4	∅19	02
14	78	2.6	∅19	03
18	71	2.0	∅19	04
26	76	2.7	∅19	05
30	83	2.5	∅19	12
36	83	2.1	∅14	06
43	78	1.8	∅14	07
50	76	1.5	∅14	13
60	71	1.3	∅14	08
68	66	1.2	∅14	09
80	65	1.0	∅14	10
100	59	0.8	∅14	11

D50 weight
Peso D50

3.00 kg

211D Ratios/Power

Rapporti/potenza 211D

Ratio	Max input power ** P_{1M} [kW]	Output shaft	Ratios code 
i _b			
2.05	0.37	∅14	01
2.35	0.37	∅14	02
2.80	0.37	∅14	03
3.38	0.37	∅14	04
4.70	0.37	∅14	05
6.22	0.37	∅14	06
8.29	0.37	∅14	07
9.83	0.25	∅14	08

211D weight
Peso 211D

1.40 kg



211D Motor flanges

Flange motore 211D

	kit code	g6	A
63B5	KD454041	138	99.5
71B5	KD454042	160	97
56B14	KD454049	80	97
63B14	KD454047	90	99.5
71B14	KD454045	105	97

How to connect D50+211D

Come collegare D50 + 211D

Worm gearbox		Ratio multiplier	Connection kit	
Standard input bore		Output shaft	With standard input bore	With coupling
D50	∅N	211D		
Ratios from 1/7 ÷ 1/30	∅19	∅14	KBR14/19	KC14P
Ratios from 1/36 ÷ 1/100	∅14		Reduction bushing is not necessary	

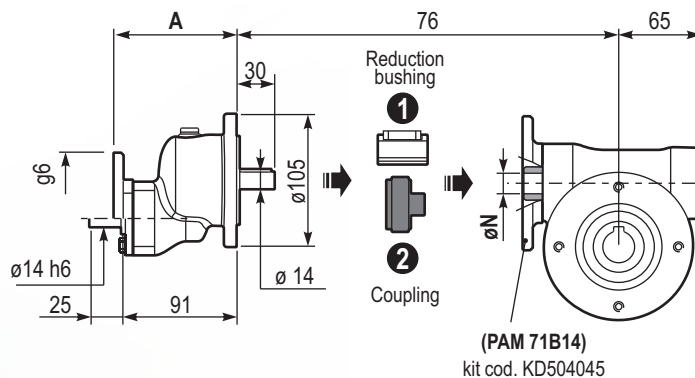
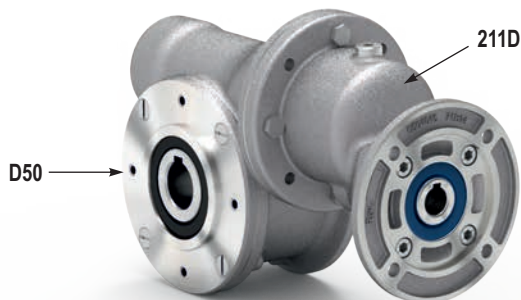

Ratios range: from 1/14 to 1/983

Range rapporti: da 1/14 a 1/983

Lubrication

Lubrificazione

Unit D50+211D is supplied with synthetic oil to assure long life lubrication. Food grade oil is available on request. See Table 1 for lubrication and recommended quantity.

Il riduttore tipo D50+211D viene fornito con olio sintetico e lubrificazione tipo "long life".

Disponibile a richiesta olio alimentare.

Vedi Tabella 1 per oli e quantità consigliati.

For all details on lubrication and plugs check our website.

Per maggiori dettagli su lubrificazione e tappi olio vedi il nostro sito web.

D50: 0.14 L	SHELL: Omala S4 WE 320	ENI: Telium VSF 320
211D: 0.05 L	SHELL: Omala S4 WE 320	ENI: Telium VSF 320

tab. 1

Calculate total ratio and output speed

Calcola il rapporto totale e la velocità di uscita

Ratios range: from 1/14 to 1/983

Range rapporti: da 1/14 a 1/983

$$i_{TOT} = i_a \cdot i_b$$

Ex.: 1/100 x 1/9.83 = 1/983 (Max ratio)

Output speed (n₂)

Velocità di uscita

$$n_2 = n_1 : i_{TOT}$$

Ex.: 1448 : 983 = 1.47 rpm

i_a : D50 ratio - Rapporto D50

i_b : 211D ratio - Rapporto 211D

** Make sure input power for 211D and output torque for D50 is as catalogue ratios.

** Prestare attenzione a selezionare la potenza in entrata del 211D ed il momento torcente del D50 secondo le tabelle del catalogo.

n₁ Input speed

Velocità di ingresso



D63 211D

VFD series with ratio multiplier RCD series

Riduttori a vite senza fine in alluminio con precoppia serie RCD

D63 Ratios/Rating

Rapporti/Selezione D63

Ratio	Max output torque ** M_{2R} [Nm]	Tooth module  [mm]	Standard input bore	Ratio code 
i _a				
7	144	3.1	ø24	01
10	155	3.1	ø24	02
15	158	3.1	ø24	03
19	158	2.6	ø24	04
24	163	2.0	ø24	05
30	168	3.2	ø24	06
36	169	2.7	ø24	07
40	161	2.5	ø24	13
45	156	2.1	ø19	08
60	150	1.6	ø19	12
67	142	1.5	ø19	09
80	136	1.3	ø19	10
94	136	1.1	ø19	11

D63 weight
Peso D63

6.00 kg

211D Ratios/Power

Rapporti/potenza 211D

Ratio	Max input power ** P_{1M} [kW]	Standard output shaft 	Ratios code
i _b			
2.05	0.37	ø14	01
2.35	0.37	ø14	02
2.80	0.37	ø14	03
3.38	0.37	ø14	04
4.70	0.37	ø14	05
6.22	0.37	ø14	06
8.29	0.37	ø14	07
9.83	0.25	ø14	08

211D weight
Peso 211D

1.40 kg

211D Motor flanges

Flange motore 211D

	kit code	g6	A
63B5	KD454041	138	99.5
71B5	KD454042	160	97
56B14	KD454049	80	97
63B14	KD454047	90	99.5
71B14	KD454045	105	97

How to connect D63+211D

Come collegare D63 + 211D

Worm gearbox	Ratio multiplier	Connection kit	
		With standard input bore	With coupling
Standard input bore	Output shaft		
D63	øN	211D	
Ratios from 1/7 ÷ 1/40	ø24	ø14	KBR14/24
Ratios from 1/45 ÷ 1/94	ø19		KD14P

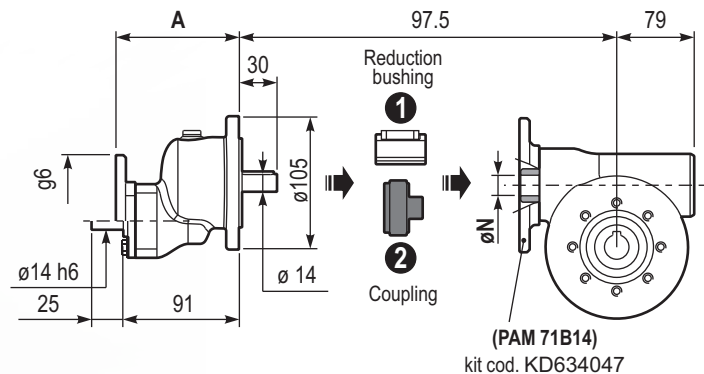

Ratios range: from 1/14 to 1/924

Range rapporti: da 1/14 a 1/924

Lubrication

Lubrificazione

Unit D63+211D is supplied with synthetic oil to assure long life lubrication. Food grade oil is available on request. See Table 1 for lubrication and recommended quantity.

Il riduttore tipo D63+211D viene fornito con olio sintetico e lubrificazione tipo "long life".

Disponibile a richiesta olio alimentare. Vedi Tabella 1 per oli e quantità consigliati.

For all details on lubrication and plugs check our website.

Per maggiori dettagli su lubrificazione e tappi olio vedi il nostro sito web.

D63: 0.40 L	SHELL: Omala S4 WE 320	ENI: Telium VSF 320
211D: 0.05 L	SHELL: Omala S4 WE 320	ENI: Telium VSF 320

Calculate total ratio and output speed

Calcola il rapporto totale e la velocità di uscita

Ratios range: from 1/14 to 1/924

Range rapporti: da 1/14 a 1/924

$$i_{TOT} = i_a \cdot i_b$$

Ex.: 1/94 x 1/9.83 = 1/924 (Max ratio)

Output speed (n₂)

Velocità di uscita

$$n_2 = n_1 : i_{TOT}$$

Ex.: 1448 : 924 = 1.57 rpm

i_a : D63 ratio - Rapporto D63

i_b : 211D ratio - Rapporto 211D

** Make sure input power for 211D and output torque for D63 is as catalogue ratios.

** Prestare attenzione a selezionare la potenza in entrata del 211D ed il momento torcente del D63 secondo le tabelle del catalogo.

n₁ Input speed



Velocità di ingresso

VFD series with ratio multiplier RCD series

Riduttori a vite senza fine in alluminio con precoppia serie RCD

D85 211D

D85 Ratios/Rating Rapporti/Selezione D85

Ratio	Max output torque $**M_{2R}$ [Nm]	Tooth module  [mm]	Standard input bore	Ratio code 
i_a				
7	296	4.23	ø28	01
10	326	4.2	ø28	02
14	350	4.5	ø28	03
20	338	3.4	ø28	04
22	338	3.1	ø28	05
28	398	4.7	ø28	06
38	386	3.5	ø24	07
46	374	3.1	ø24	08
52	332	2.7	ø24	09
67	332	2.1	ø24	10
74	308	1.9	ø24	11
96	278	1.5	ø24	12

211D Ratios/Power Rapporti/potenza 211D

Ratio	Max input power $**P_{1M}$ [kW]	Standard output shaft	Ratios code 
i_b			
2.05	0.37	ø14	01
2.35	0.37	ø14	02
2.80	0.37	ø14	03
3.38	0.37	ø14	04
4.70	0.37	ø14	05
6.22	0.37	ø14	06
8.29	0.37	ø14	07
9.83	0.25	ø14	08

211D Motor flanges Flange motore 211D

	kit code	g6	A
63B5	KD454041	138	99.5
71B5	KD454042	160	97
56B14	KD454049	80	97
63B14	KD454047	90	99.5
71B14	KD454045	105	97

How to connect D85+211D

Come collegare D85 + 211D

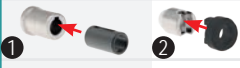
Worm gearbox	Ratio multiplier	Connection kit	
		With standard input bore	With coupling
Standard input bore	Output shaft		
D85	øN	211D	
Ratios from 1/7 ÷ 1/28	ø28	ø14	KBR14/28
Ratios from 1/38 ÷ 1/96	ø24		KE14P

D85 weight
Peso D85 **11.0 kg**

211D weight
Peso 211D **1.40 kg**

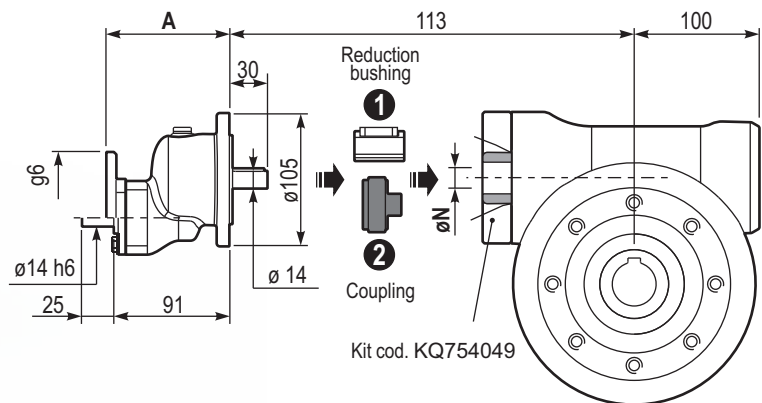
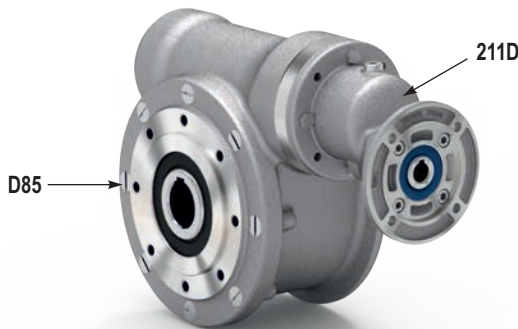

Ratios range: from 1/14 to 1/944

Range rapporti: da 1/14 a 1/924

Lubrication

Lubrificazione

Unit D85+211D is supplied with synthetic oil to assure long life lubrication. Food grade oil is available on request. See Table 1 for lubrication and recommended quantity.

Il riduttore tipo D85+211D viene fornito con olio sintetico e lubrificazione tipo "long life".

Disponibile a richiesta olio alimentare.

Vedi Tabella 1 per oli e quantità consigliati.

For all details on lubrication and plugs check our website.

Per maggiori dettagli su lubrificazione e tappi olio vedi il nostro sito web.

D85: 1.20 L	SHELL: Omala S4 WE 320	ENI: Telium VSF 320
211D: 0.05 L	SHELL: Omala S4 WE 320	ENI: Telium VSF 320

tab. 1

Calculate total ratio and output speed

Calcola il rapporto totale e la velocità di uscita

Ratios range: from 1/14 to 1/944

Range rapporti: da 1/14 a 1/924

$$i_{TOT} = i_a \cdot i_b$$

Ex.: $1/96 \times 1/9.83 = 1/944$ (Max ratio)

Output speed (n_2)

Velocità di uscita

$$n_2 = n_1 : i_{TOT}$$

Ex.: $1448 : 944 = 1.53$ rpm

i_a : D85 ratio - Rapporto D85

i_b : 211D ratio - Rapporto 211D

** Make sure input power for 211D and output torque for D85 is as catalogue ratios.

** Prestare attenzione a selezionare la potenza in entrata del 211D ed il momento torcente del D85 secondo le tabelle del catalogo.

n_1 Input speed

Velocità di ingresso

Input speed (n_1) = 1400 min⁻¹

Output speed n_2 [min ⁻¹]	Ratio i	Motor power P_{1M} [kW]	Output torque M_{2M} [Nm]	Service factor f_s	Nominal power P_{1R} [kW]	Nominal torque M_{2R} [Nm]	B5 motor flanges		B14 motor flanges		Dynamic efficiency RD	Tooth module [mm]	Ratio code
							-A	-B	-O	-P			
9.3	150	0.06	29	1.2	0.07	35	B		B-C		48	1.44	01
6.7	210	0.06	39	0.9	0.05	35	B		B-C		45	1.44	02
4.7	300	0.06*	35	<0.8	0.05	35	B		B-C		36	1.44	03
3.1	450	0.06*	35	<0.8	0.03	35	B		B-C		33	1.44	04
2.3	600	0.06*	35	<0.8	0.03	35	B		B-C		30	1.44	05
1.6	900	0.06*	35	<0.8	0.02	35	B		B-C		27	1.44	06
1.2	1200	0.06*	35	<0.8	0.02	35	B		B-C		26	1.44	07
0.8	1830	0.06*	35	<0.8	0.01	35	B		B-C		24	1.44	08
0.6	2400	0.06*	35	<0.8	0.01	35	B		B-C		22	1.44	09

* Power higher than the maximum one which can be supported by the gearbox. Select according to the torque M_{2R}
Potenza superiore a quella massima sopportabile dal riduttore. Selezionare in base al momento torcente M_{2R}

-  **Motor flanges available**
Flange motore disponibili
-  **B) Supplied with reduction bushing**
Fornito con bussola di riduzione
-  **B) Available on request without reduction bushing**
Disponibile a richiesta senza bussola di riduzione
-  **C) Motor flange holes position**
Posizione fori flangia motore

Lubrication

Lubrificazione

Unit 3D3 is supplied with synthetic oil to assure long life lubrication. Food grade oil is available on request. See Table 1 for lubrication and recommended quantity. See Table 2 for possible radial and axial loads on the gearbox.

Il riduttore tipo 3D3 viene fornito con olio sintetico e lubrificazione tipo "long life". Disponibile a richiesta olio alimentare. Vedi Tabella 1 per oli e quantità consigliati. Vedi Tabella 2 per i carichi radiali e assiali applicabili al riduttore.

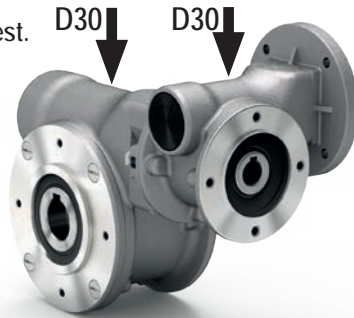

D30: 0.03 L	Shell Omala S4 WE 320	Eni Telium VSF 320
-------------	--------------------------	-----------------------

For all details on lubrication and plugs check our website. **Tab. 1**
Per maggiori dettagli su lubrificazione e tappi olio vedi il nostro sito web.

Suggested

Suggerito

Stainless steel protection cap (on request).

Coperchio di protezione in acciaio inox a richiesta.

Kit cod. KN300209

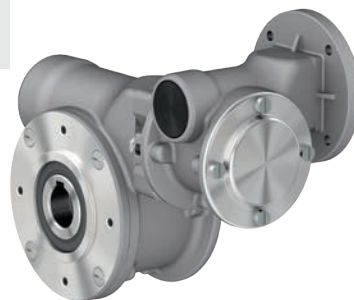

Radial and axial loads

Carichi radiali e assiali

Output shaft

Albero di uscita

n_2 [min ⁻¹]	FA [N]	FR [N]
25	300	1800
15	400	2000

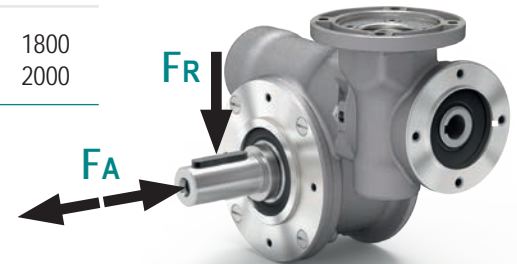

Input shaft

Albero in entrata

n_1 [min ⁻¹]	FA [N]	FR [N]
1400	20	100

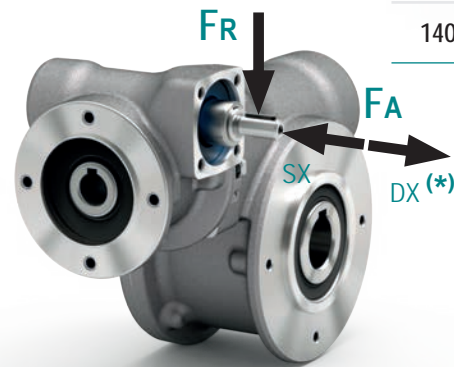

* Strong axial loads in the DX direction are not allowed.
** Non sono consentiti forti carichi assiali con direzione DX*

Tab. 2

P3D3UNI.. Basic gearbox
Riduttore base

M. flanges	Kit code	øF	A
56B5	KD304041	120	62
63B5	KD304042	140	63
56B14	KD304046	80	62
63B14	KD304045	90	63

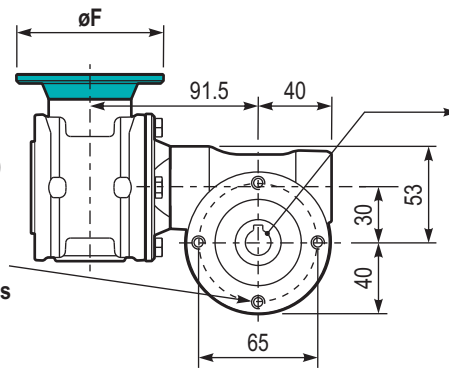
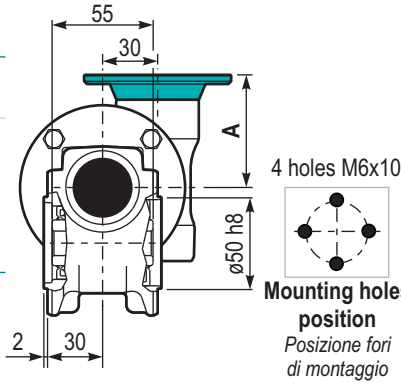

Gearbox weight
Peso riduttore 2.15 kg

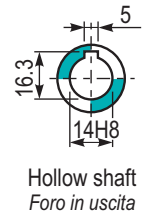

P3D3PA... Feet
Piedini

Type	T	Kit code
B**	87	K0309022
I*	80	KN309022

** Zink plated
* Stainless steel

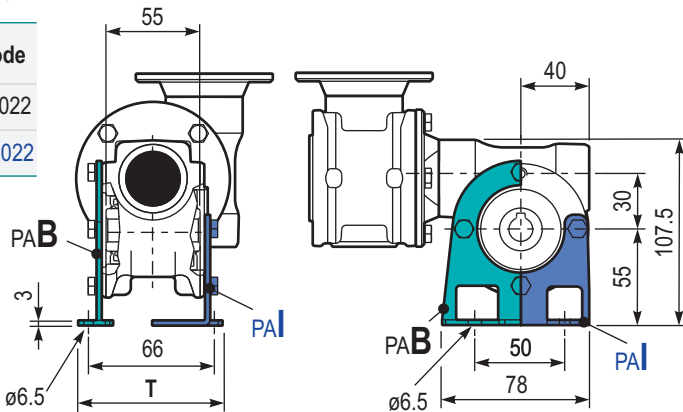

P3D3PBB.. Feet
Piedini

P3D3PV... Feet
Piedini

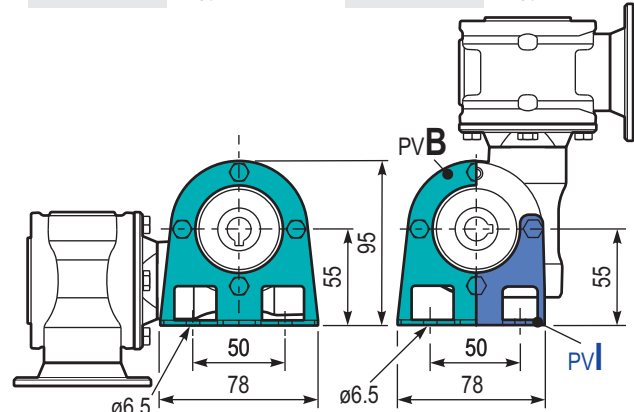

P3D3FL.. Output flange
Flangia uscita

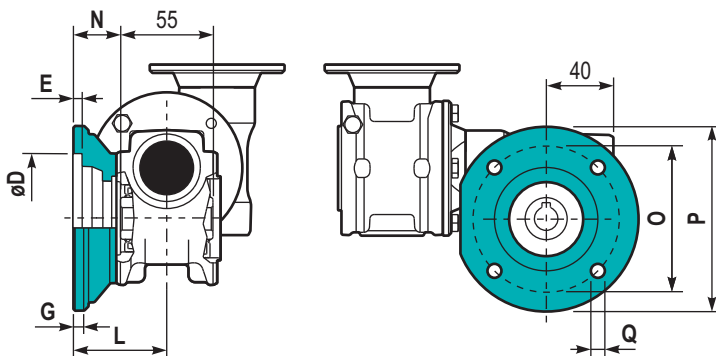

P3D3BR... Reaction arm
Braccio di reazione

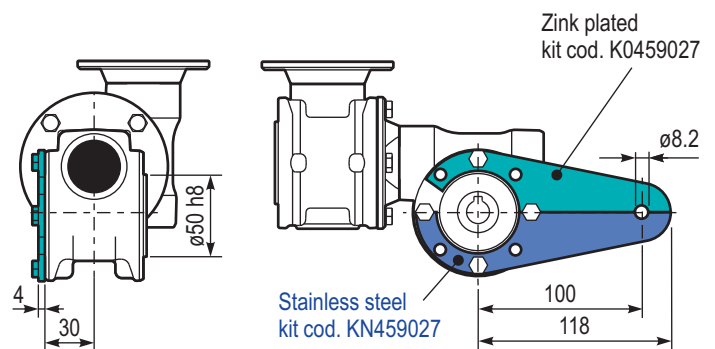

Type	øD	E	G	L	N	O	P	Q	Kit code
C	50 ^{+0.15} / _{+0.05}	6	6	50.5	23	68	80	7	K0309010
L	60 ^{+0.15} / _{+0.05}	6	6	55.5	28	87	110	8.5	K0459010

R3D3UNI.. Input shaft
Albero in entrata

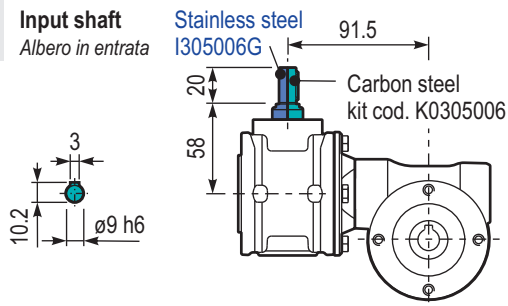

P3D3..SMA Single output shaft
Albero semplice in uscita

kit cod. KN300209
Protection cap (on request)
A richiesta coperchio di protezione

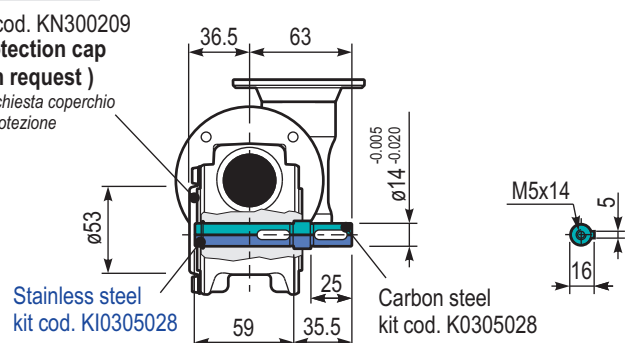

Input speed (n_1) = 1400 min⁻¹

Output speed n_2 [min ⁻¹]	Ratio i	Motor power P_{1M} [kW]	Output torque M_{2M} [Nm]	Service factor $f.s$	Nominal power P_{1R} [kW]	Nominal torque M_{2R} [Nm]	B5 motor flanges		B14 motor flanges		Dynamic efficiency RD	Tooth module [mm]	Ratio code
							-A 56	-B 63	-O 56	-P 63			
10.0	140	0.12	57	1.2	0.14	69	B		B-C		50	2.2	01
7.0	200	0.12	79	0.9	0.11	69	B		B-C		48	2.2	02
5.0	280	0.06	52	1.3	0.08	69	B		B-C		45	2.4	03
3.3	420	0.06	62	1.1	0.07	69	B		B-C		36	1.6	04
2.5	560	0.06	76	0.9	0.05	69	B		B-C		33	2.5	05
1.9	740	0.06	91	0.8	0.05	69	B		B-C		30	1.8	06
1.5	920	0.06*	69	<0.8	0.04	69	B		B-C		27	1.5	07
1.3	1120	0.06*	69	<0.8	0.03	69	B		B-C		26	2.5	08
0.9	1480	0.06*	69	<0.8	0.03	69	B		B-C		24	1.8	09
0.8	1840	0.06*	69	<0.8	0.02	69	B		B-C		22	1.5	10
0.6	2400	0.06*	69	<0.8	0.02	69	B		B-C		21	1.2	11

* Power higher than the maximum one which can be supported by the gearbox. Select according to the torque M_{2R}
Potenza superiore a quella massima sopportabile dal riduttore. Selezionare in base al momento torcente M_{2R}

Motor flanges available
Flange motore disponibili



B) Supplied with reduction bushing
Fornito con bussola di riduzione



B) Available on request without reduction bushing
Disponibile a richiesta senza bussola di riduzione



C) Motor flange holes position
Posizione fori flangia motore

Lubrication

Lubrificazione

Unit 4D3 is supplied with synthetic oil to assure long life lubrication. Food grade oil is available on request. See Table 1 for lubrication and recommended quantity. See Table 2 for possible radial and axial loads on the gearbox.

Il riduttore tipo 4D3 viene fornito con olio sintetico e lubrificazione tipo "long life". Disponibile a richiesta olio alimentare. Vedi Tabella 1 per oli e quantità consigliati. Vedi Tabella 2 per i carichi radiali e assiali applicabili al riduttore.

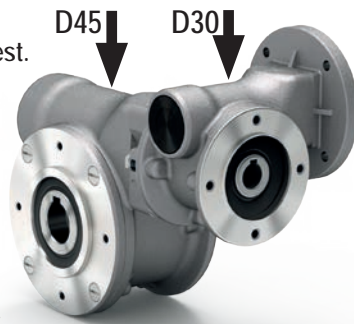

D45: 0.09 L

D30: 0.03 L

Shell

Omala S4 WE 320

Eni

Telium VSF 320

For all details on lubrication and plugs check our website.
Per maggiori dettagli su lubrificazione e tappi olio vedi il nostro sito web.

Tab. 1

Suggested

Suggerito

Stainless steel protection cap (on request).

Coperchio di protezione in acciaio inox a richiesta.

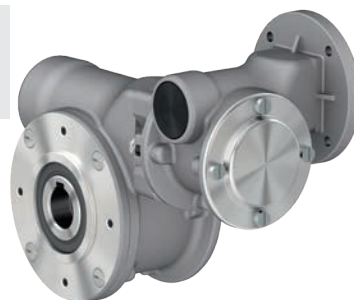

Kit cod. KN300209

Radial and axial loads

Carichi radiali e assiali

Output shaft

Albero di uscita

n_2 [min ⁻¹]	FA [N]	FR [N]
25	300	1800
15	400	2000

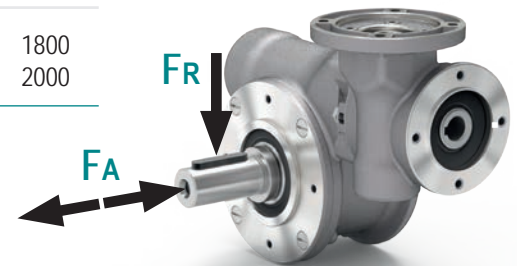

Input shaft

Albero in entrata

n_1 [min ⁻¹]	FA [N]	FR [N]
1400	20	100

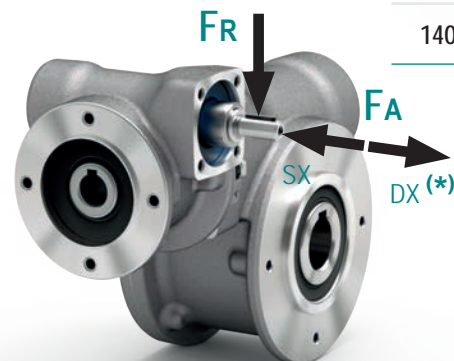

* Strong axial loads in the DX direction are not allowed.

* Non sono consentiti forti carichi assiali con direzione DX

Tab. 2

P4D3UNI.. Basic gearbox
Riduttore base

M. flanges	Kit code	øF	A
56B5	KD304041	120	62
63B5	KD304042	140	63
56B14	KD304046	80	62
63B14	KD304045	90	63

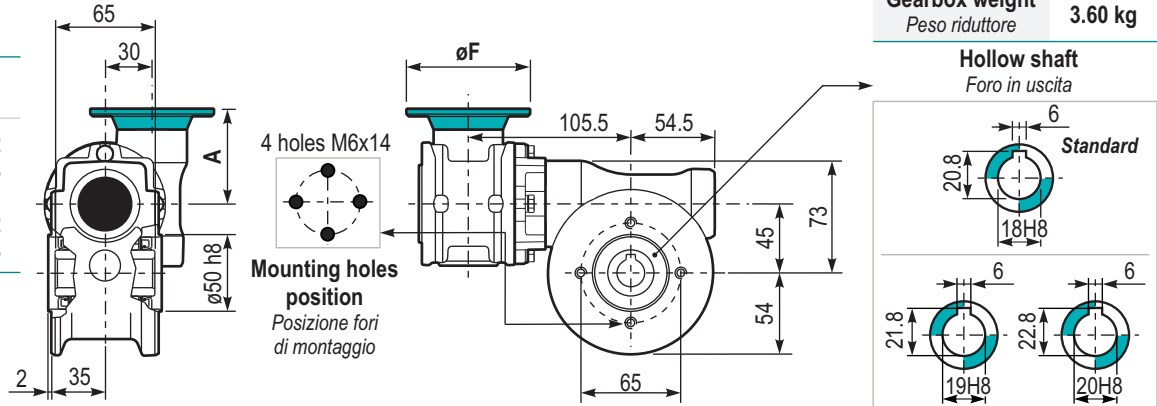

Gearbox weight
Peso riduttore **3.60 kg**

Hollow shaft
Foro in uscita

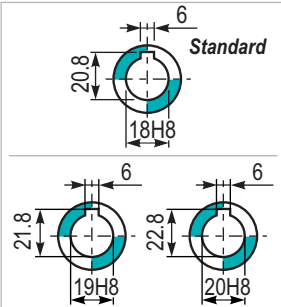

P4D3PA... Feet
Piedini

Type	T	Kit code
B**	102	K0459022
I*	100	KN459022

** Zink plated
* Stainless steel

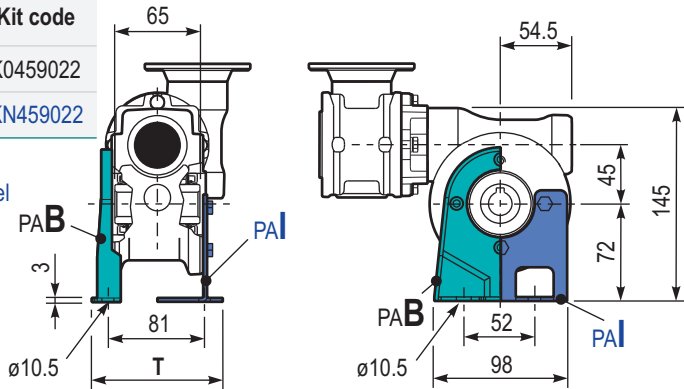

P4D3PBB... Feet
Piedini

P4D3PV... Feet
Piedini

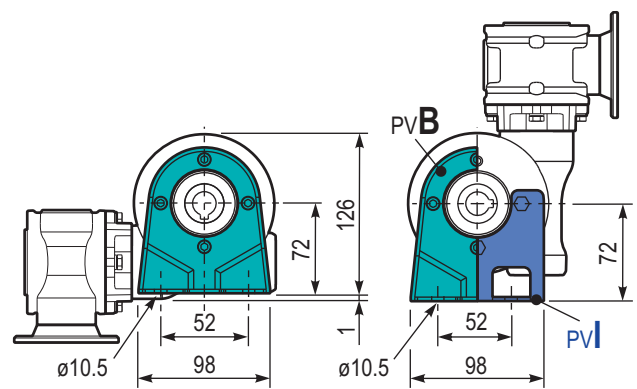

P4D3FL... Output flange
Flangia uscita

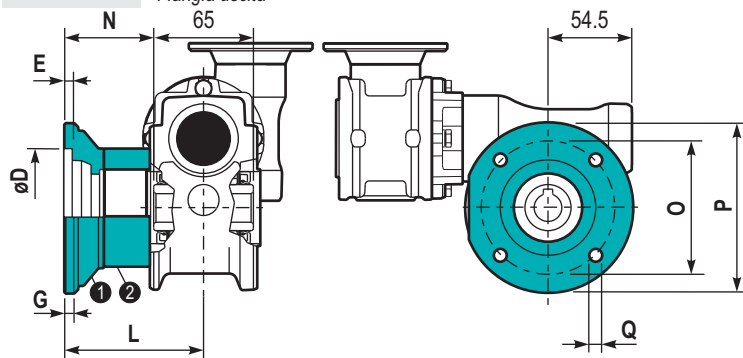

Type	øD	E	G	L	N	O	P	Q	Kit code
C	60 ^{+0.15} / _{+0.05}	9	9	60.5	28	87	110	8.5	① K0459010 ② - ③ K0459010 ④ K0450200
L	60 ^{+0.15} / _{+0.05}	9	9	90.5	58	87	110	8.5	

P4D3BR... Reaction arm
Braccio di reazione

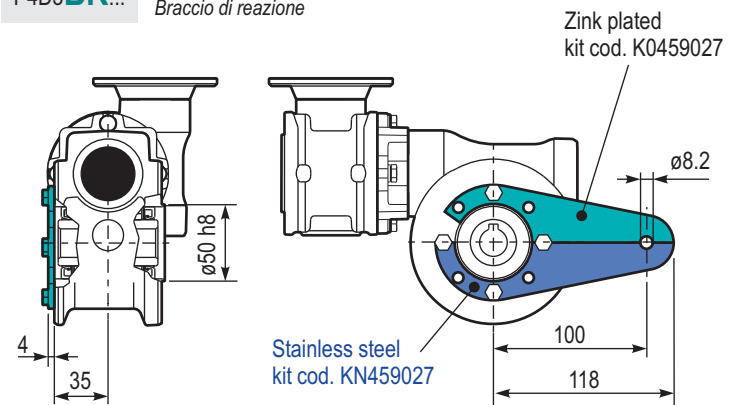

R4D3UNI... Input shaft
Albero in entrata

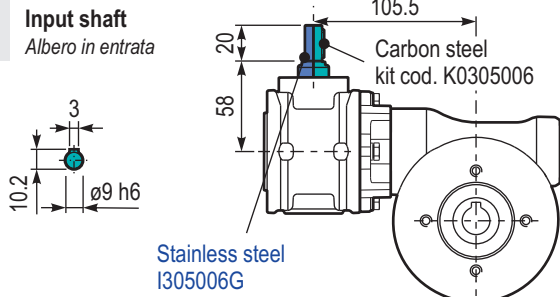

P4D3..SMB Single output shaft
Albero semplice in uscita

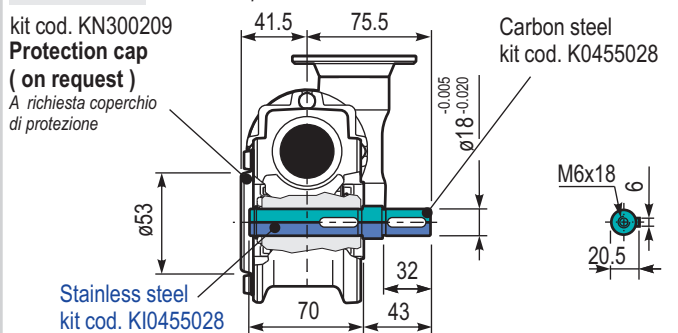

Input speed (n_1) = 1400 min⁻¹

Output speed n_2 [min ⁻¹]	Ratio i	Motor power P_{1M} [kW]	Output torque M_{2M} [Nm]	Service factor f_s	Nominal power P_{1R} [kW]	Nominal torque M_{2R} [Nm]	B5 motor flanges		B14 motor flanges		Dynamic efficiency RD	Tooth module [mm]	Ratio code
							-A	-B	-O	-P			
5.6	252	0.12	97	1.1	0.14	109	B		B-C		47	2.1	01
3.9	360	0.12	124	0.9	0.11	109	B		B-C		42	2.1	02
2.6	540	0.09	129	0.8	0.08	109	B		B-C		39	2.1	03
1.9	720	0.06	106	1.0	0.06	109	B		B-C		36	2.1	04
1.6	860	0.06	113	1.0	0.06	109	B		B-C		32	1.8	05
1.2	1200	0.06	133	0.8	0.05	109	B		B-C		27	1.3	06
1.0	1440	0.06*	109	<0.8	0.04	109	B		B-C		26	2.1	07
0.8	1720	0.06*	109	<0.8	0.04	109	B		B-C		25	1.8	08
0.6	2400	0.06*	109	<0.8	0.03	104	B		B-C		21	1.3	09

* Power higher than the maximum one which can be supported by the gearbox. Select according to the torque M_{2R}

Potenza superiore a quella massima sopportabile dal riduttore. Selezionare in base al momento torcente M_{2R}

Motor flanges available
Flange motore disponibili



B) Supplied with reduction bushing
Fornito con bussola di riduzione



B) Available on request without reduction bushing
Disponibile a richiesta senza bussola di riduzione



C) Motor flange holes position
Posizione fori flangia motore

Lubrication

Lubrificazione

Unit 5D3 is supplied with synthetic oil to assure long life lubrication. Food grade oil is available on request. See Table 1 for lubrication and recommended quantity. See Table 2 for possible radial and axial loads on the gearbox.

Il riduttore tipo 5D3 viene fornito con olio sintetico e lubrificazione tipo "long life". Disponibile a richiesta olio alimentare. Vedi Tabella 1 per oli e quantità consigliati. Vedi Tabella 2 per i carichi radiali e assiali applicabili al riduttore.

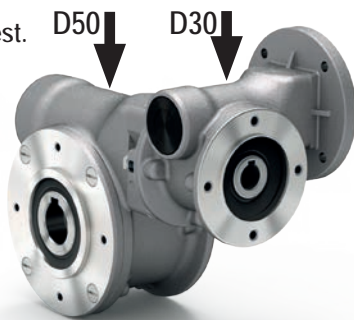

D50: 0.14 L

D30: 0.03 L

Shell

Omala S4 WE 320

Eni

Telium VSF 320

For all details on lubrication and plugs check our website.
Per maggiori dettagli su lubrificazione e tappi olio vedi il nostro sito web.

Tab. 1

Suggested

Suggerito

Stainless steel protection cap (on request).

Coperchio di protezione in acciaio inox a richiesta.

Kit cod. KN300209

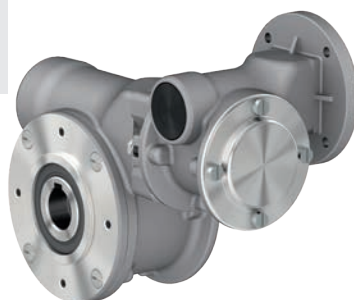

Radial and axial loads

Carichi radiali e assiali

Output shaft

Albero di uscita

n_2 [min ⁻¹]	F_A [N]	F_R [N]
25	480	2500
15	560	2800

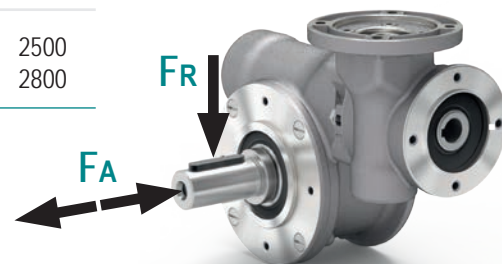

Input shaft

Albero in entrata

n_1 [min ⁻¹]	F_A [N]	F_R [N]
1400	20	100

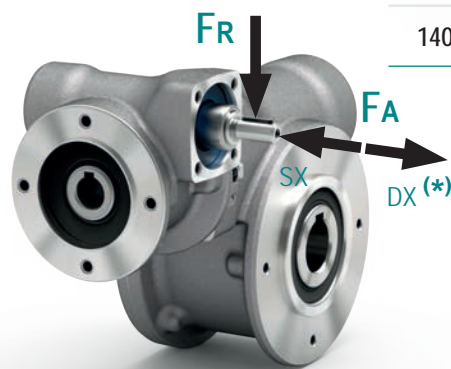

* Strong axial loads in the DX direction are not allowed.

* Non sono consentiti forti carichi assiali con direzione DX

Tab. 2

P5D3 **UNI..** Basic gearbox
Riduttore base

M. flanges	Kit code	øF	A
56B5	KD304041	120	62
63B5	KD304042	140	63
56B14	KD304046	80	62
63B14	KD304045	90	63

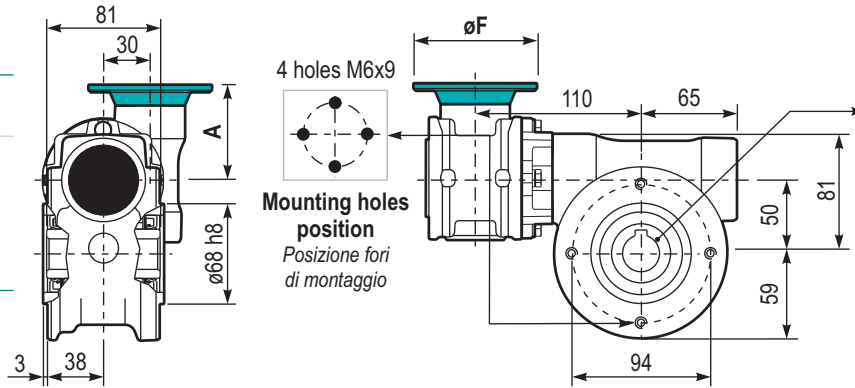

Gearbox weight
Peso riduttore **4.20 kg**

Hollow shaft
Foro in uscita

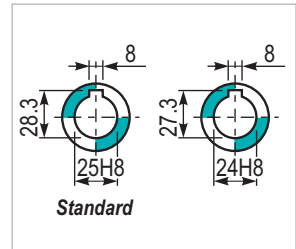

P5D3 **PA...** Feet
Piedini

Type	T	Kit code
B**	123	K0509022
I*	122	KN509022

** Zink plated
* Stainless steel

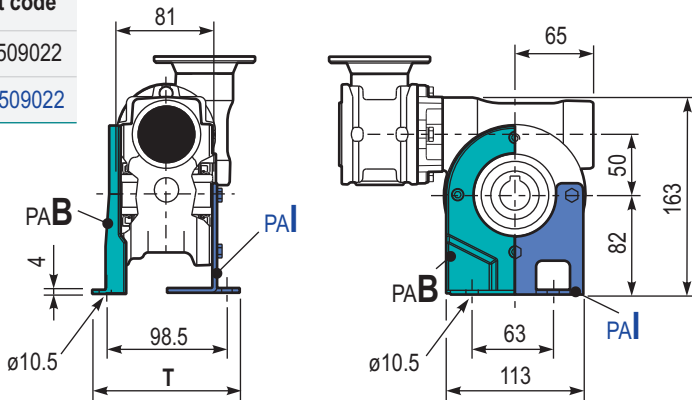

P5D3 **PBB..** Feet
Piedini

P5D3 **PV...** Feet
Piedini

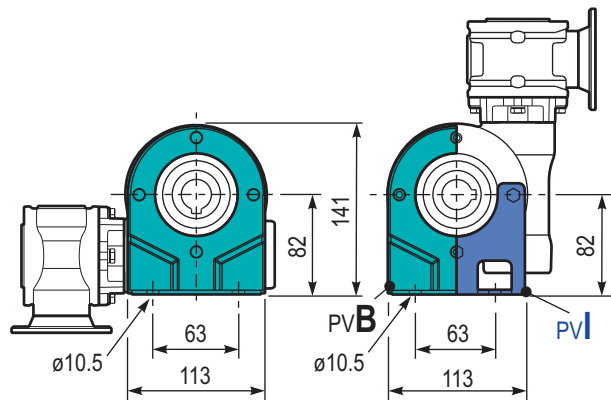

P5D3 **FL..** Output flange
Flangia uscita

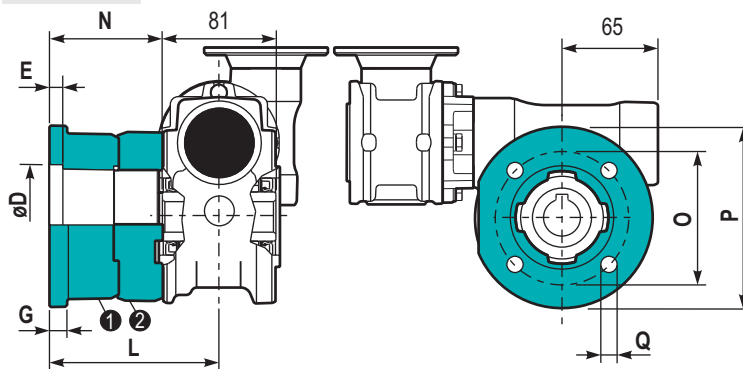

Type	øD	E	G	L	N	O	P	Q	Kit code
C	70 ^{+0.20} / _{+0.15}	9	12	85	44.5	90	123	10.5	① K0509010 ② -
L	70 ^{+0.20} / _{+0.15}	9	12	114.5	74	90	123	10.5	① K0509010 ② K0500200

P5D3 **BR...** Reaction arm
Braccio di reazione

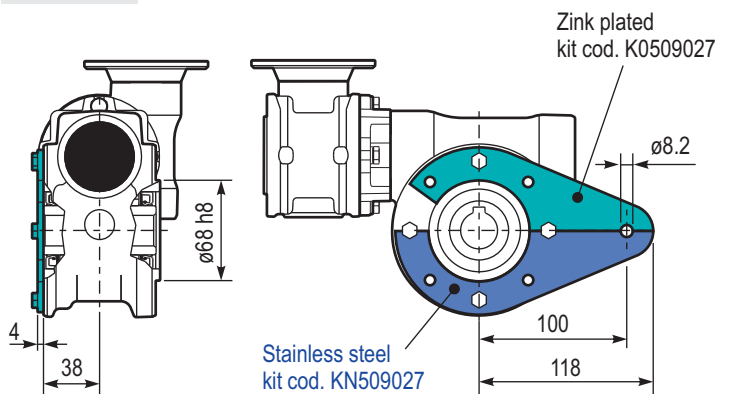

R5D3 **UNI..** Input shaft
Albero in entrata

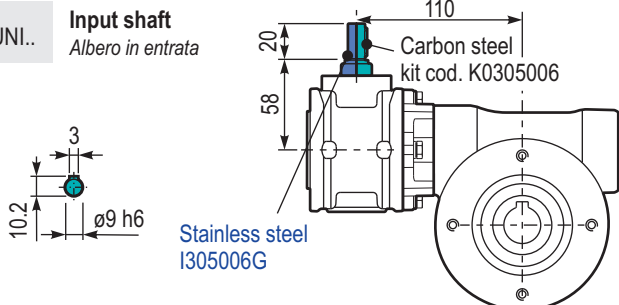

P5D3 **SMF** Single output shaft
Albero semplice in uscita

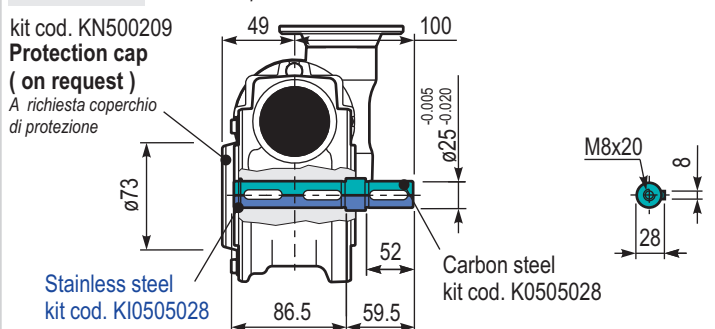

Input speed (n_1) = 1400 min⁻¹

Output speed n_2 [min ⁻¹]	Ratio i	Motor power P_{1M} [kW]	Output torque M_{2M} [Nm]	Service factor $f.s$	Nominal power P_{1R} [kW]	Nominal torque M_{2R} [Nm]	B5 motor flanges		B14 motor flanges		Dynamic efficiency RD	Tooth module [mm]	Ratio code
							-A	-B	-O	-P			
5.6	252	0.18	142	1.6	0.29	230	B		B-C		46	2.7	01
3.9	360	0.18	181	1.3	0.23	230	B		B-C		41	2.7	02
2.6	540	0.12	164	1.4	0.17	230	B		B-C		37	2.7	03
1.9	720	0.12	200	1.1	0.14	230	B		B-C		34	2.7	04
1.3	1080	0.12	265	0.9	0.10	230	B		B-C		30	2.7	05
1.0	1440	0.12*	230	<0.8	0.09	230	B		B-C		27	2.7	06
0.5	2745	0.12*	230	<0.8	0.05	230	B		B-C		23	2.1	07

* Power higher than the maximum one which can be supported by the gearbox. Select according to the torque M_{2R}
Potenza superiore a quella massima sopportabile dal riduttore. Selezionare in base al momento torcente M_{2R}

-  **Motor flanges available**
Flange motore disponibili
-  **B) Supplied with reduction bushing**
Fornito con bussola di riduzione
-  **B) Available on request without reduction bushing**
Disponibile a richiesta senza bussola di riduzione
-  **C) Motor flange holes position**
Posizione fori flangia motore

Lubrication

Lubrificazione

Unit 6D3 is supplied with synthetic oil to assure long life lubrication. Food grade oil is available on request. See Table 1 for lubrication and recommended quantity. See Table 2 for possible radial and axial loads on the gearbox.

Il riduttore tipo 6D3 viene fornito con olio sintetico e lubrificazione tipo "long life". Disponibile a richiesta olio alimentare. Vedi Tabella 1 per oli e quantità consigliati. Vedi Tabella 2 per i carichi radiali e assiali applicabili al riduttore.

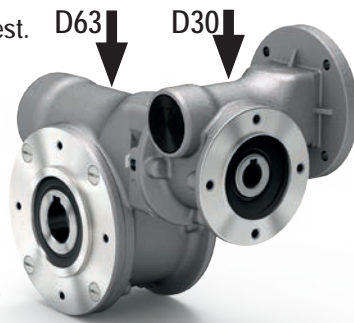

D63: 0.40 L	Shell	Eni
D30: 0.03 L	Omala S4 WE 320	Telium VSF 320

For all details on lubrication and plugs check our website.
Per maggiori dettagli su lubrificazione e tappi olio vedi il nostro sito web.

Tab. 1

Suggested

Suggerito

Stainless steel protection cap (on request).

Coperchio di protezione in acciaio inox a richiesta.

Kit cod. KN300209

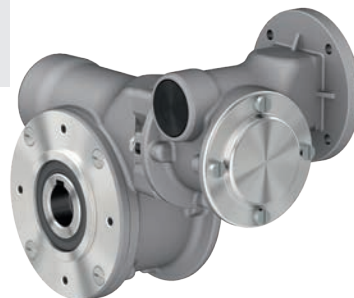

Radial and axial loads

Carichi radiali e assiali

Output shaft

Albero di uscita

n_2 [min ⁻¹]	FA [N]	FR [N]
25	700	3800
15	800	4000

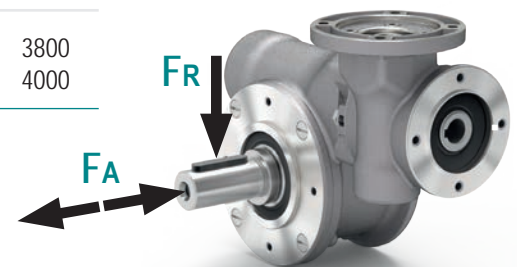

Input shaft

Albero in entrata

n_1 [min ⁻¹]	FA [N]	FR [N]
1400	20	100

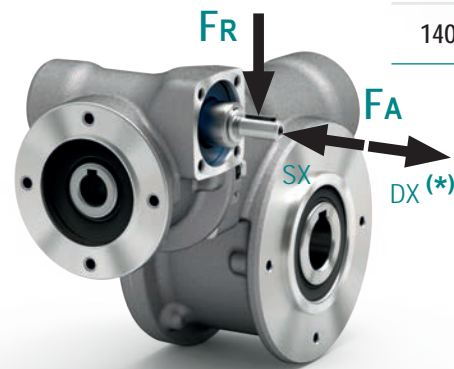

* Strong axial loads in the DX direction are not allowed.
* Non sono consentiti forti carichi assiali con direzione DX

Tab. 2

P6D3 **UNI..** Basic gearbox
Riduttore base

M. flanges	Kit code	øF	A
56B5	KD304041	120	62
63B5	KD304042	140	63
56B14	KD304046	80	62
63B14	KD304045	90	63

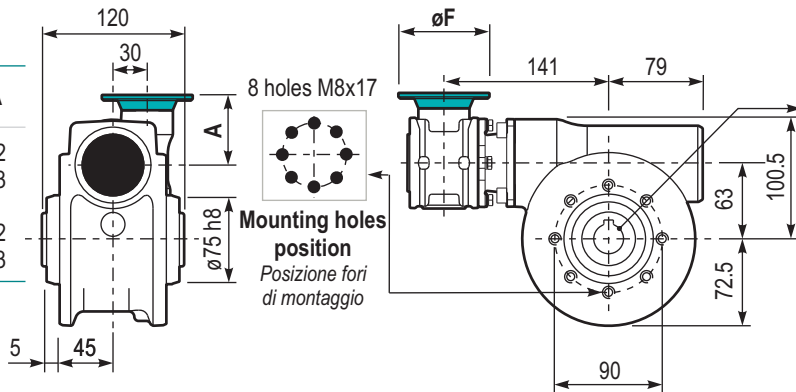

Gearbox weight
Peso riduttore **7.50 kg**

Hollow shaft
Foro in uscita

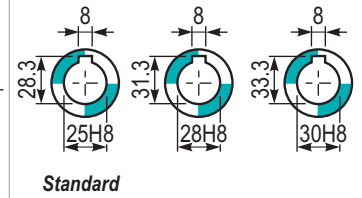

P6D3 **PA..** Feet
Piedini

Type	T	Kit code
B**	144	K0639022
I*	130	KN639022

** Zink plated
* Stainless steel

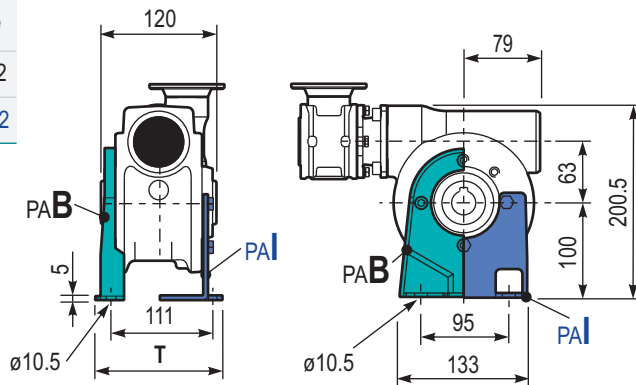

P6D3 **PBB..** Feet
Piedini

P6D3 **PV..** Feet
Piedini

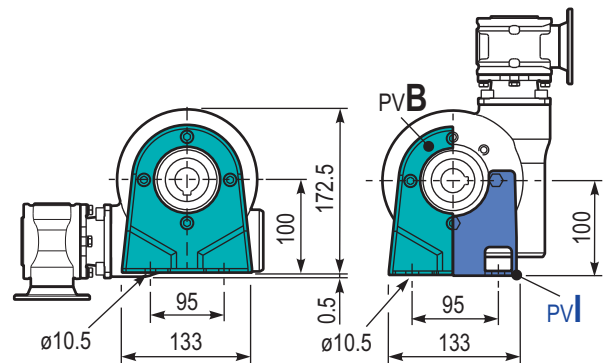

P6D3 **FL..** Output flange
Flangia uscita

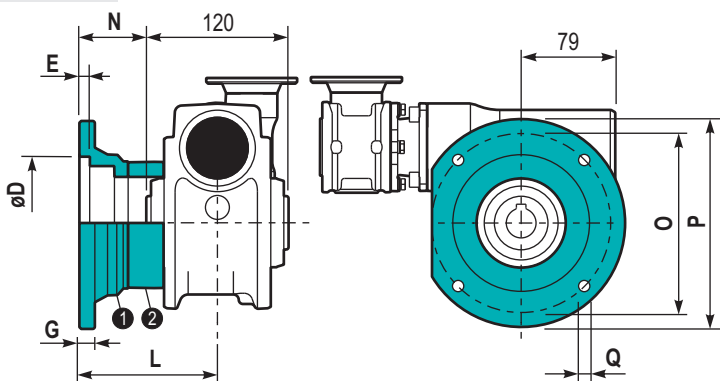

Type	øD	E	G	L	N	O	P	Q	Kit code
C	115 ^{+0.20} _{+0.15}	7	13	86	26	150	175	11	① K0639010 ② -
L	115 ^{+0.20} _{+0.15}	7	13	116	56	150	175	11	① K0639010 ② K0630200

P6D3 **BR..** Reaction arm
Braccio di reazione

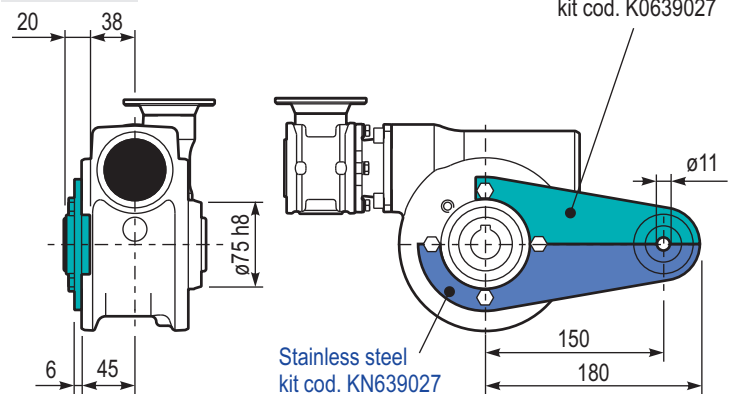

R6D3 **UNI..** Input shaft
Albero in entrata

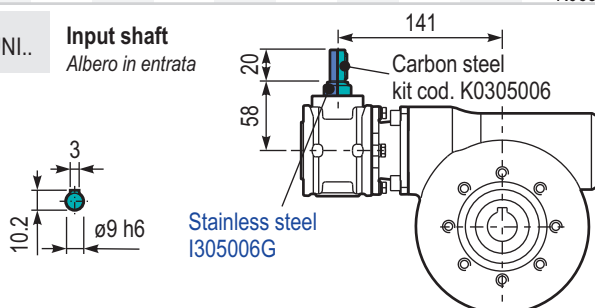

P6D3 **SMF** Single output shaft
Albero semplice in uscita

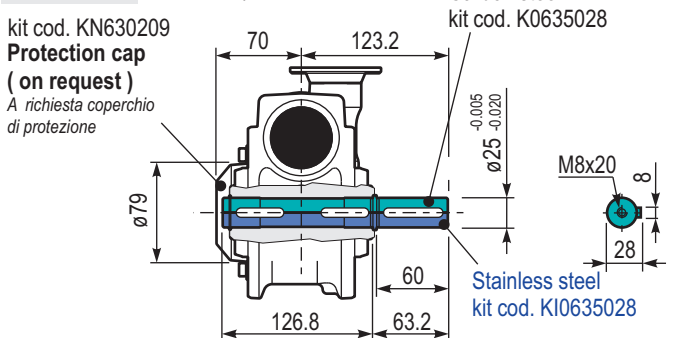

Input speed (n_1) = 1400 min⁻¹

Output speed n_2 [min ⁻¹]	Ratio i	Motor power P_{1M} [kW]	Output torque M_{2M} [Nm]	Service factor $f.s$	Nominal power P_{1R} [kW]	Nominal torque M_{2R} [Nm]	B5 motor flanges			B14 motor flanges			Dynamic efficiency RD	Tooth module [mm]	Ratio code
							-B 63	-C 71	-O 56	-P 63	-Q 71				
5.6	252	0.25	198	1.3	0.33	265	B		B-C	B-C		46	2.7	01	
3.9	360	0.18	186	1.4	0.26	265	B		B-C	B-C		42	2.7	02	
2.8	504	0.18	241	1.1	0.20	265	B		B-C	B-C		39	2.7	03	
1.9	756	0.12	204	1.3	0.16	265	B		B-C	B-C		33	2.7	04	
1.4	1008	0.12	256	1.0	0.12	265	B		B-C	B-C		31	2.7	05	
1.1	1332	0.12*	265	<0.8	0.10	265	B		B-C	B-C		30	2.7	06	
0.8	1656	0.12*	265	<0.8	0.08	265	B		B-C	B-C		28	2.7	07	
0.6	2160	0.12*	265	<0.8	0.07	265	B		B-C	B-C		26	2.7	08	
0.6	2520	0.12*	265	<0.8	0.06	265	B		B-C	B-C		25	2.7	09	

* Power higher than the maximum one which can be supported by the gearbox. Select according to the torque M_{2R}
Potenza superiore a quella massima sopportabile dal riduttore. Selezionare in base al momento torcente M_{2R}

-  **Motor flanges available**
Flange motore disponibili
-  **B) Supplied with reduction bushing**
Fornito con bussola di riduzione
-  **B) Available on request without reduction bushing**
Disponibile a richiesta senza bussola di riduzione
-  **C) Motor flange holes position**
Posizione fori flangia motore

Lubrication

Lubrificazione

Unit 6D4 is supplied with synthetic oil to assure long life lubrication. Food grade oil is available on request. See Table 1 for lubrication and recommended quantity. See Table 2 for possible radial and axial loads on the gearbox.

Il riduttore tipo 6D4 viene fornito con olio sintetico e lubrificazione tipo "long life". Disponibile a richiesta olio alimentare. Vedi Tabella 1 per oli e quantità consigliati. Vedi Tabella 2 per i carichi radiali e assiali applicabili al riduttore.

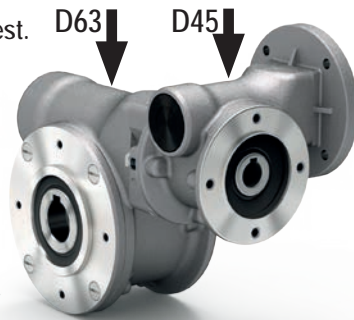

D63: 0.40 L	Shell	Eni
D45: 0.09 L	Omala S4 WE 320	Telium VSF 320

For all details on lubrication and plugs check our website.
Per maggiori dettagli su lubrificazione e tappi olio vedi il nostro sito web. **Tab. 1**

Suggested

Suggerito

Stainless steel protection cap (on request).

Coperchio di protezione in acciaio inox a richiesta.

Kit cod. KN300209

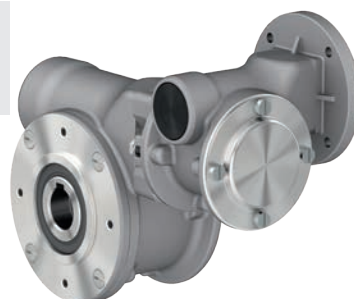

Radial and axial loads

Carichi radiali e assiali

Output shaft

Albero di uscita

n_2 [min ⁻¹]	FA [N]	FR [N]
25	700	3800
15	800	4000

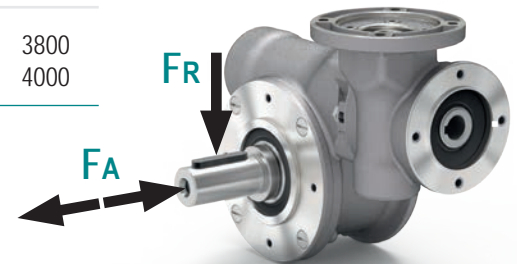

Input shaft

Albero in entrata

n_1 [min ⁻¹]	FA [N]	FR [N]
1400	42	210

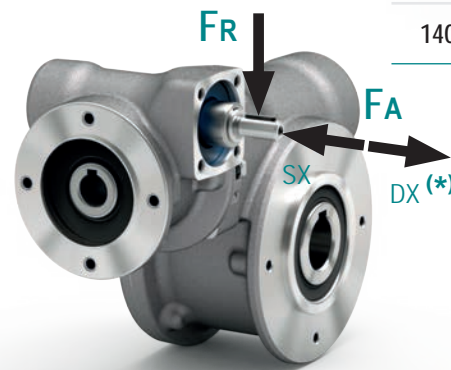

* Strong axial loads in the DX direction are not allowed.
* Non sono consentiti forti carichi assiali con direzione DX

Tab. 2

P6D4UNI.. Basic gearbox
Riduttore base

M. flanges	Kit code	øF	A
63B5	KD454041	138	74
71B5	KD454042	160	71.5
56B14	KD454049	80	71.5
63B14	KD454047	90	74
71B14	KD454045	105	71.5

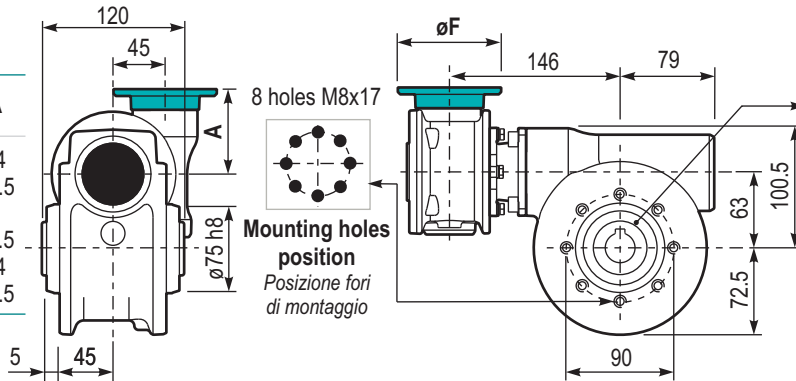

Gearbox weight
Peso riduttore 8.90 kg

Hollow shaft
Foro in uscita

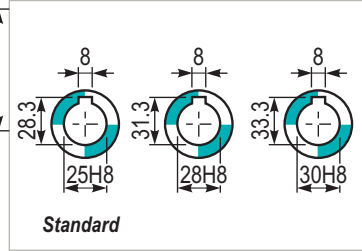

P6D4PA... Feet
Piedini

Type	T	Kit code
B**	144	K0639022
I*	130	KN639022

** Zink plated
* Stainless steel

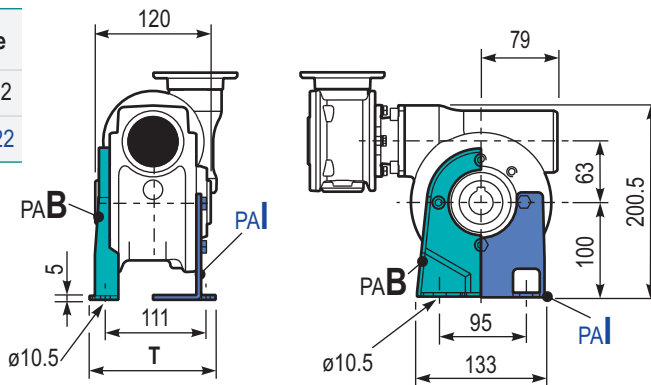

P6D4PBB... Feet
Piedini

P6D4PV... Feet
Piedini

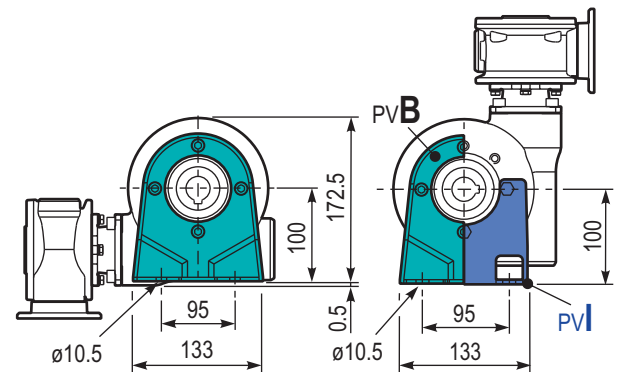

P6D4FL... Output flange
Flangia uscita

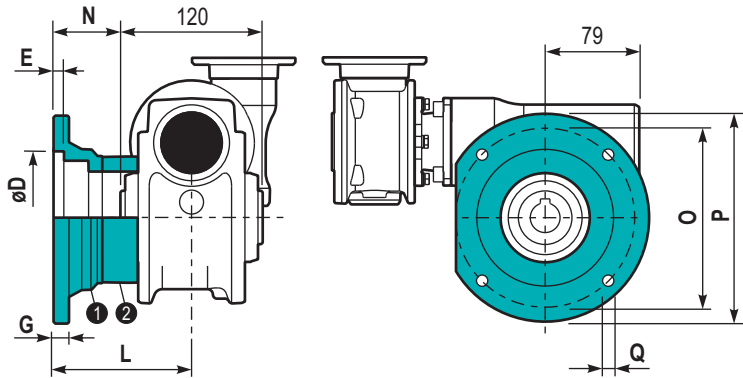

Type	øD	E	G	L	N	O	P	Q	Kit code
C	115 ^{+0.20} / _{-0.15}	7	13	86	26	150	175	11	① K0639010 ② -
L	115 ^{+0.20} / _{-0.15}	7	13	116	56	150	175	11	① K0639010 ② K0630200

P6D4BR... Reaction arm
Braccio di reazione

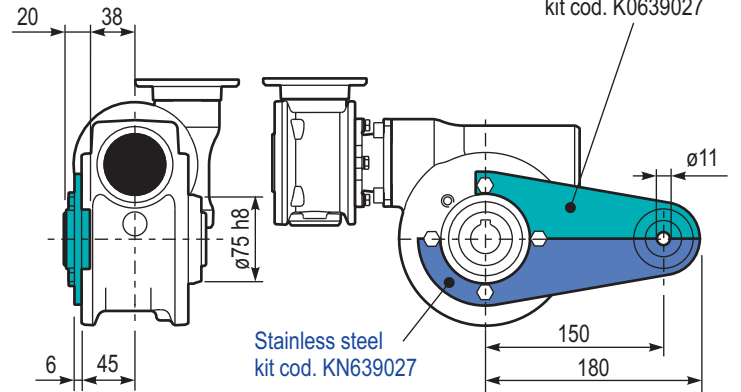

R6D4UNI.. Input shaft
Albero in entrata

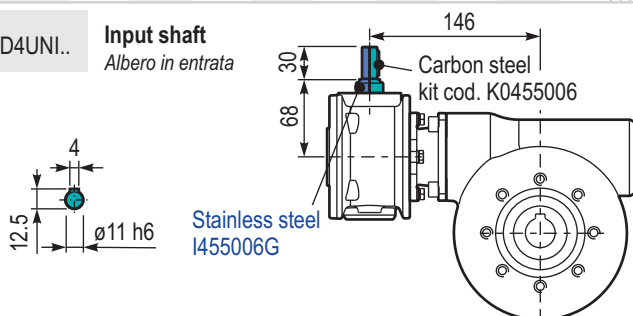

P6D4...SMF Single output shaft
Albero semplice in uscita

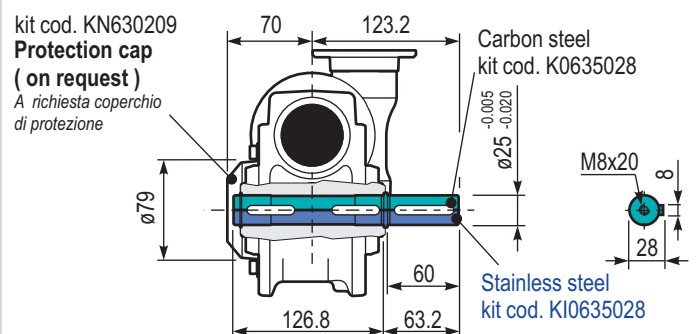

Input speed (n_1) = 1400 min⁻¹

Output speed n_2 [min ⁻¹]	Ratio i	Motor power P_{1M} [kW]	Output torque M_{2M} [Nm]	Service factor $f.s$	Nominal power P_{1R} [kW]	Nominal torque M_{2R} [Nm]	B5 motor flanges			B14 motor flanges			Dynamic efficiency RD	Tooth module [mm]	Ratio code
							-B 63	-C 71		-O 56	-P 63	-Q 71			
10	140	0.37	205	1.8	0.66	368	B			B-C	B-C		58	4.5	01
7.1	196	0.37	257	1.4	0.53	368	B			B-C	B-C		52	4.7	02
5.0	280	0.37	332	1.6	0.58	518	B			B-C	B-C		47	4.7	03
3.6	392	0.37	435	1.2	0.44	518	B			B-C	B-C		44	4.7	04
2.4	588	0.25	371	1.4	0.35	518	B			B-C	B-C		37	4.7	05
1.8	784	0.25	455	1.1	0.28	518	B			B-C	B-C		34	4.7	06
1.4	1036	0.18	420	1.2	0.22	518	B			B-C	B-C		33	4.7	07
1.1	1288	0.18	474	1.1	0.20	518	B			B-C	B-C		30	4.7	08
0.7	1960	0.12	449	1.2	0.14	518	B			B-C	B-C		28	4.7	09
0.5	2856	0.12	584	0.9	0.11	518	B			B-C	B-C		25	4.7	10

* Power higher than the maximum one which can be supported by the gearbox. Select according to the torque M_{2R}

Potenza superiore a quella massima sopportabile dal riduttore. Selezionare in base al momento torcente M_{2R}

Motor flanges available

Flange motore disponibili



B) Supplied with reduction bushing

Fornito con bussola di riduzione



B) Available on request without reduction bushing

Disponibile a richiesta senza bussola di riduzione



C) Motor flange holes position

Posizione fori flangia motore

Lubrication

Lubrificazione

Unit 8D4 is supplied with synthetic oil to assure long life lubrication.

Food grade oil is available on request.

See Table 1 for lubrication and recommended quantity.

See Table 2 for possible radial and axial loads on the gearbox.

Il riduttore tipo 8D4 viene fornito con olio sintetico e lubrificazione tipo "long life".
Disponibile a richiesta olio alimentare.
Vedi Tabella 1 per oli e quantità consigliati.
Vedi Tabella 2 per i carichi radiali e assiali applicabili al riduttore.

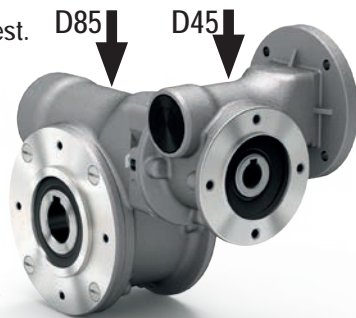

D85: 1.20 L

Shell

Omala S4 WE 320

Eni

Telium VSF 320

For all details on lubrication and plugs check our website.

Per maggiori dettagli su lubrificazione e tappi olio vedi il nostro sito web.

Tab. 1

Suggested

Sugerito

Stainless steel protection cap (on request).

Coperchio di protezione in acciaio inox a richiesta.

Kit cod. KN300209

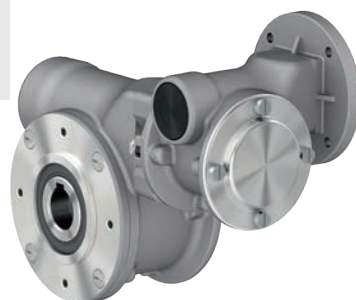

Radial and axial loads

Carichi radiali e assiali

Output shaft

Albero di uscita

n_2 [min ⁻¹]	FA [N]	FR [N]
25	1000	5000
15	1160	5800

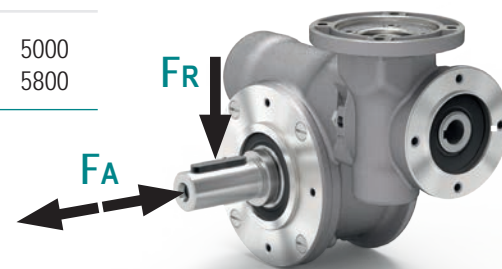

Input shaft

Albero in entrata

n_1 [min ⁻¹]	FA [N]	FR [N]
1400	42	210

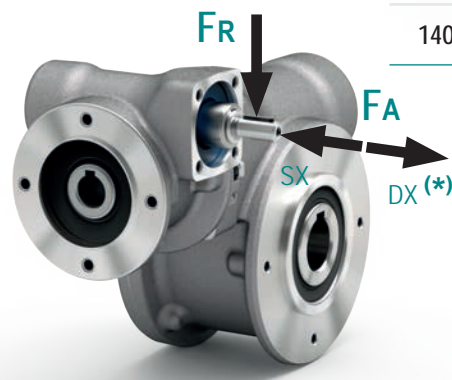

* Strong axial loads in the DX direction are not allowed.

* Non sono consentiti forti carichi assiali con direzione DX

Tab. 2

P8D4UNI.. Basic gearbox
Riduttore base

M. flanges	Kit code	øF	A
63B5	KD454041	138	74
71B5	KD454042	160	71.5
56B14	KD454049	80	71.5
63B14	KD454047	90	74
71B14	KD454045	105	71.5

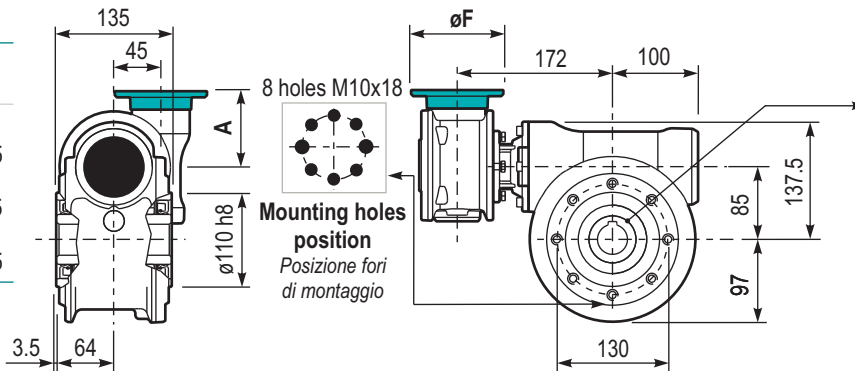

Gearbox weight
Peso riduttore **19.50 kg**

Hollow shaft
Foro in uscita

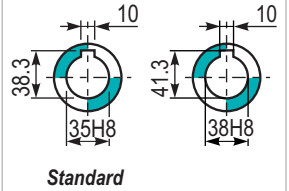

P8D4PA.. Feet
Piedini

Type	T	V	Kit code
B**	182	180	K0859022
I*	176	172	KN859022

** Zink plated
* Stainless steel

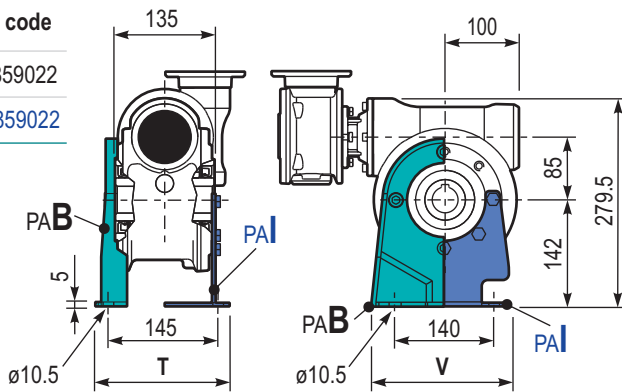

P8D4PBB.. Feet
Piedini

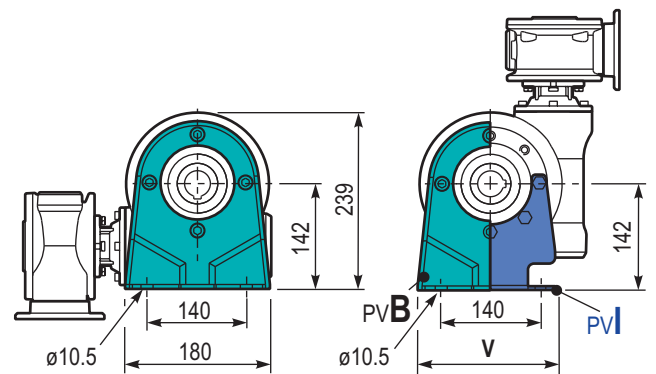

P8D4PV... Feet
Piedini

P8D4FL.. Output flange
Flangia uscita

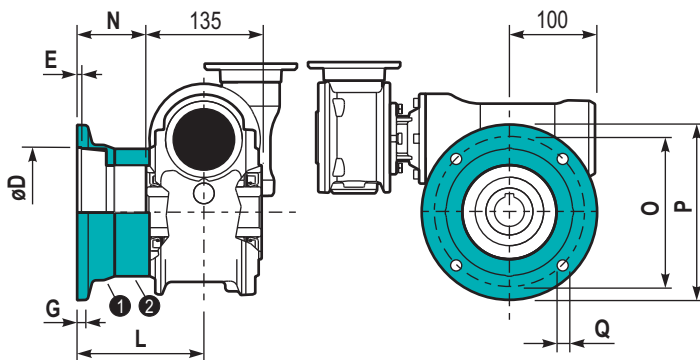

Type	øD	E	G	L	N	O	P	Q	Kit code
C	152 ^{+0.06} _{-0.00}	5	16	108	40.5	176	205	13	① K0859010 ② -
L	152 ^{+0.06} _{-0.00}	5	16	148.5	81	176	205	13	① K0859010 ② K0850201

P8D4BR.. Reaction arm
Braccio di reazione

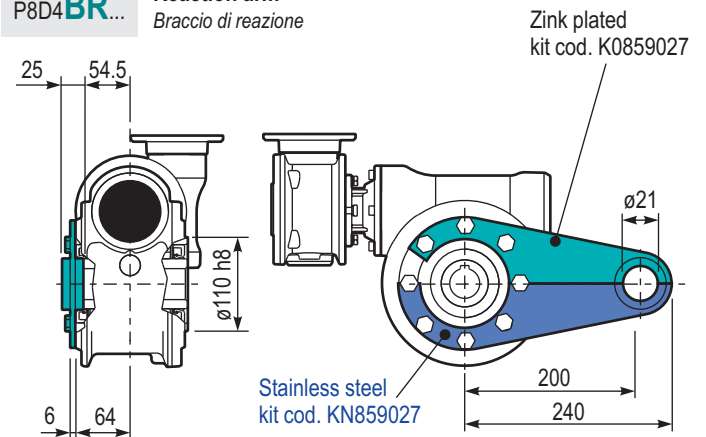

R8D4UNI.. Input shaft
Albero in entrata

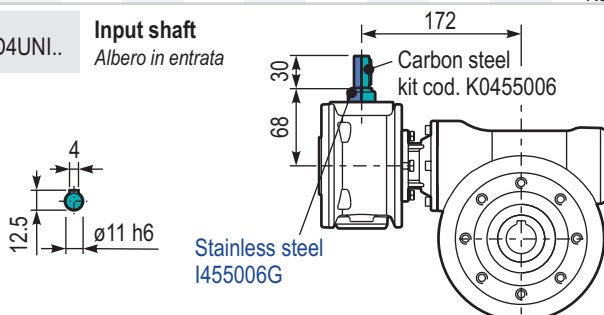

P8D4..SMK Single output shaft
Albero semplice in uscita

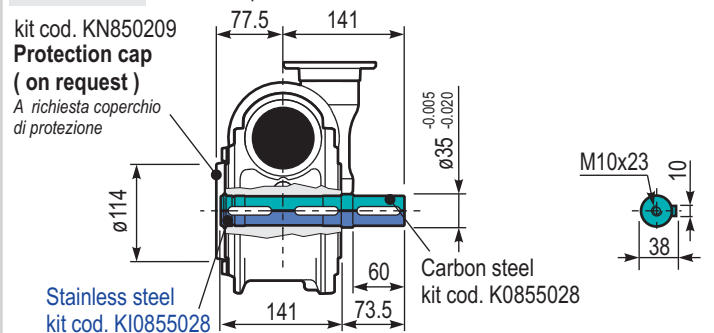



D RCD series Smooth surface aluminum ratio multipliers

Riduttori ad uno stadio in alluminio con superficie liscia

Section **2**
Sezione 2

ALUMINUM





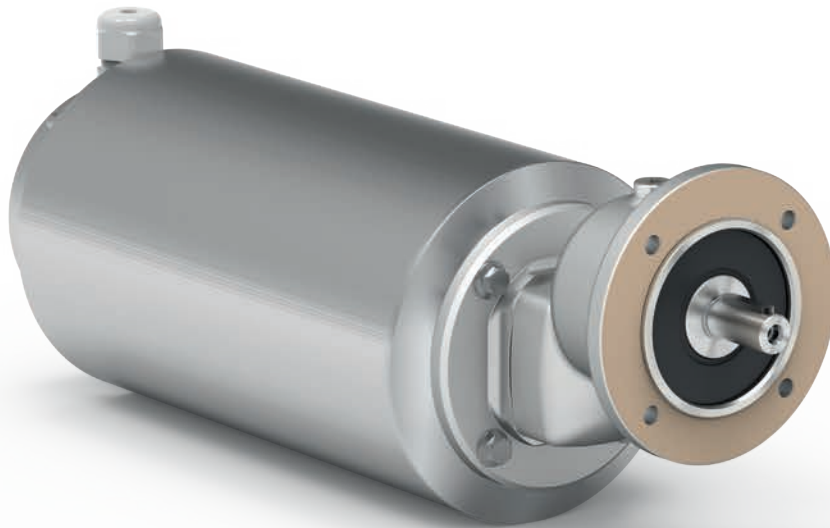

IP66













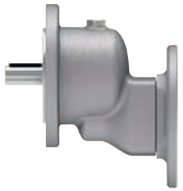



CE

On req.
A rich.



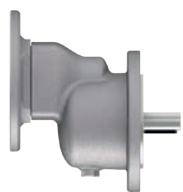

How to order Codifica

P	211D	-F	2.05	S	C
Type <i>Tipo</i>	Size <i>Grandezza</i>	Mounting <i>Montaggio</i>	Ratio <i>Rapporto</i>	Output shaft <i>Albero lento</i>	Shaft material <i>Materiale albero</i>
<p>P</p> 	211D	<p>-F</p> 	See technical data table <i>Vedi tabelle dati tecnici</i>		
<p>M</p> 		<p>→ Standard</p> <p>S → ø14</p>		<p>C Carbon steel <i>Acciaio</i></p> <p>I Stainless steel (Only for standard shaft) <i>Acciaio inox</i> (Solo per albero standard)</p>	
<p>B</p> 					
<p>R</p> 					

I	-Q	B3	ST	A	For M type specify terminal box position
Output flange <i>Flangia uscita</i>	Motor size <i>Grandezza motore</i>	Mounting position <i>Posizione di montaggio</i>	Input bore <i>Foro entrata</i>	Coating <i>Trattamento</i>	<i>Per tipo M specificare posizione morsetti</i>
 <p>I → ø105</p>	Motor flanges <i>Flange motore</i> 	B3 	ST Standard bore <i>Foro standard</i>	A Standard in aluminum <i>Standard in alluminio</i> 	A 
	IEC B14 <p>-O → 56 B14 (ø80) -P → 63 B14 (ø90) -Q → 71 B14 (ø105)</p>	B6 	N NTT coating <i>NTT Rivestimento</i> 	B 	
	Without flange <i>Senza flangia</i>  <p>211D</p> <p>-Z → ø9 (IEC 56) -0 → ø11 (IEC 63) -1 → ø14 (IEC 71)</p>	B7 	P Painted <i>Verniciato</i> 	C 	
	Type R <i>Tipo R</i>  <p>211D</p> <p>-1 → ø14</p>	B8 	D 		
		V5 			
		V6 			

The dynamic efficiency is **0.98** for all ratios

Input speed (n_1) = 1400 min⁻¹

Output speed n_2 [min ⁻¹]	Ratio i	Motor power P_{1M} [kW]	Output torque M_{2M} [Nm]	Service factor $f.s$	Nominal power P_{1R} [kW]	Nominal torque M_{2R} [Nm]	B5 motor flanges		B14 motor flanges			Output shaft 	Ratios code 
							-B 63	-C 71	-O 56	-P 63	-Q 71		
682	2.05	0.37	5	2.0	0.73	10			C	C		1939	01
595	2.35	0.37	6	2.1	0.76	12			C	C		1740	02
500	2.80	0.37	7	2.0	0.75	14			C	C		1542	03
414	3.38	0.37	8	2.0	0.75	17			C	C		1344	04
298	4.70	0.37	12	1.7	0.64	20			C	C	standard ø14	1047	05
225	6.22	0.37	15	1.5	0.55	23			C	C		956	06
169	8.29	0.37	20	1.0	0.36	20			C	C		758	07
142	9.83	0.25	16	1.0	0.24	16			C	C		659	08

Motor flanges available
Flange motore disponibili

 **B) Supplied with reduction bushing**
Fornito con bussola di riduzione

B) Available on request without reduction bushing
Disponibile a richiesta senza bussola di riduzione

 **C) Motor flange holes position**
Posizione fori flangia motore

Lubrication

Lubrificazione

Unit 211D is supplied with synthetic oil to assure long life lubrication.
Food grade oil is available on request.

See Table 1 for lubrication and recommended quantity.

See Table 2 for possible radial and axial loads on the gearbox.

Il riduttore tipo 211D viene fornito con olio sintetico e lubrificazione tipo "long life".

Disponibile a richiesta olio alimentare.

Vedi Tabella 1 per oli e quantità consigliati.

Vedi Tabella 2 per i carichi radiali e assiali applicabili al riduttore.

**Oil quantity for
all positions:
0.05 L**

Quantità olio per tutte
le posizioni: 0.05 L

Shell
Omala S4 WE 320

Eni
Telium VSF 320

Radial and axial loads

Carichi radiali e assiali

Output shaft

Albero di uscita

n_2 [min ⁻¹]	FA [N]	FR [N]
700	101	504
600	120	600
400	138	696
300	151	756
200	175	876
140	192	960

$$F_{eq} = F_R \cdot \frac{34.5}{X + 19.5}$$

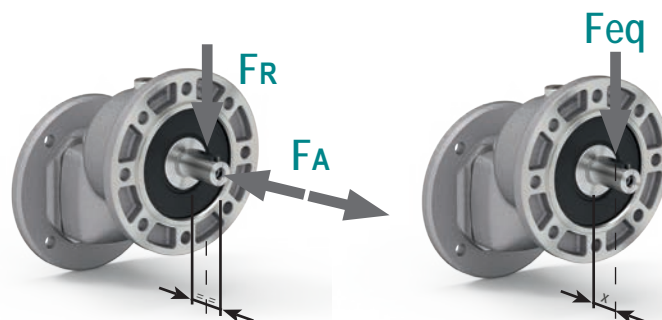

Tab. 1

Tab. 2

P211D-F... **Basic gearbox**
Riduttore base

Gearbox weight 1.40 kg
Peso riduttore

M. flanges	Kit code	k1	g6
63 B5	KD454041	99.5	138
71 B5	KD454042	97	160
56 B14	KD454049	97	80
63 B14	KD454047	99.5	90
71 B14	KD454045	97	105

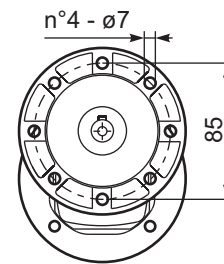
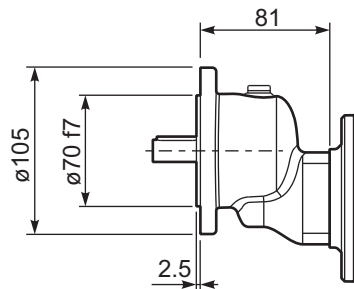
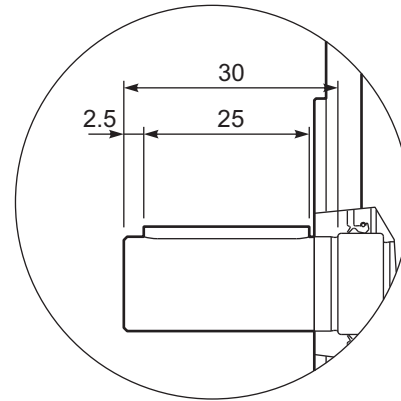
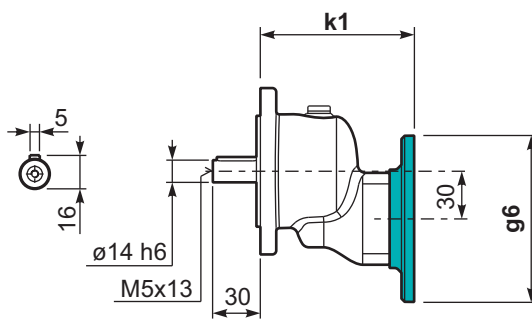

R211D-F... **Basic gearbox**
Riduttore base

kit cod. KC355061

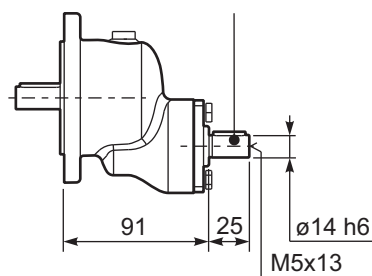



N VFN series Full stainless steel round worm gearboxes

Riduttori a vite senza fine tondo completamente in acciaio inox

Section **3**
Sezione 3

The best solution for the resistance to the corrosion. Suitable for all applications.

*La migliore soluzione per la resistenza alla corrosione.
Adatto a tutte le applicazioni.*

AISI 316L

IP66

CE

NSF

COMPONENT

















On req.
A rich.















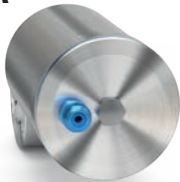

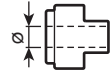
IP69k

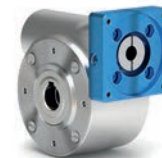
Ex
ATEX



How to order Codifica

P	N45	UNI	N	10	0	MB	I
Type <i>Tipo</i>	Size <i>Grandezza</i>	Mounting <i>Montaggio</i>	Position <i>Posizione</i>	Ratio <i>Rapporto</i>	Hub Output shaft <i>Mozzo corona Albero uscita</i>	Diameter <i>Diametro</i>	Input / output shaft material <i>Materiale albero in entrata e uscita</i>
P 	Worm gearboxes <i>Riduttori a vite senza fine</i>	UNI 	N 	See technical data table <i>Vedi tabelle dati tecnici</i>	0 Hollow <i>Mozzo</i> 	→ Standard N30 MA → ø14	I Stainless steel <i>Acciaio inox</i> The quill input hollow bore is always in carbon steel <i>Il foro cavo in entrata è sempre in acciaio</i>
M 		FLL 			S Solid output shaft <i>Albero in uscita</i> 	N45 MB → ø18 MC → ø19 MD → ø20 N50 ME → ø24 MF → ø25	
B 	N30 N45 N50 N63 N85	BRI Stainless steel <i>Acciaio inox</i> 	Select L or R position for output flange <i>Selezionare la posizione L o R per la flangia in uscita</i>			N63 MF → ø25 MG → ø28 MH → ø30	
R 		PAI Stainless steel <i>Acciaio inox</i> 	L Left <i>Sinistra</i> 				N85 MK → ø35
		PVI Stainless steel <i>Acciaio inox</i> 	R Right <i>Destra</i> 				Output male shaft is available only for standard bore <i>Albero maschio in uscita è disponibile solo per fori standard</i>

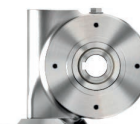
N		C	-R	B3	ST	For M type specify terminal box position
Protection cap <i>Coperchio di protezione</i>			Motor size <i>Grandezza motore</i>	Mounting position <i>Posizione di montaggio</i>	Input bore <i>Foro entrata</i>	<i>Per tipo M specificare posizione morsettiera</i>
Left <i>Sinistra</i>	Right <i>Destra</i>	Motor flanges <i>Flange motore</i>		B3	ST Standard bore* <i>Foro standard*</i>	A
					Input bore without reduction bushing -O → 9mm -P → 11mm -Q → 14mm -R → 19mm -T → 24mm -U → 28mm -V → 38mm	
N Without protection cap <i>Senza coperchietto di protezione</i>	N Without protection cap <i>Senza coperchietto di protezione</i>	IEC B14 -O → 56 B14 (ø80) -P → 63 B14 (ø90) -Q → 71 B14 (ø105) -R → 80 B14 (ø120) -T → 90 B14 (ø140) -U → 100-112B14 (ø160)		B8 		Coupling Standard (IEC)  -A → 9mm -B → 11mm -C → 14mm -D → 19mm -E → 24mm -F → 28mm
		Brushless  BB → 50/70-M5 BC → 60/75-M5 BD → 70/90-M6 BE → 80/100-M6 BF → 95/115-M8 BG → 110/145-M8 BH → 130/165-M8 Brushless-Tech catalogue is available in our website <i>Catalogo Brushless-Tech è disponibile nel nostro sito web</i>		B6 	Brushless*  -2 → 11mm -3 → 14mm -4 → 19mm -5 → 22mm -6 → 24mm	
C Closed <i>Chiuso</i>	C Closed <i>Chiuso</i>	Without flange <i>Senza flangia</i> -M → Metric 		B7 		Ready for input coupling <i>Predisposto per giunto</i> -0 Type B <i>Tipo B</i> 
		Type R <i>Tipo R</i> -0 → Metric 		V5 	* With reduction bushing where applicable <i>* Con bussola di riduzione dove prevista</i>	
				V6 		

Input speed (n_1) = 1400 min⁻¹

Output speed n_2 [min ⁻¹]	Ratio i	Motor power P_{1M} [kW]	Output torque M_{2M} [Nm]	Service factor $f.s$	Nominal power P_{1R} [kW]	Nominal torque M_{2R} [Nm]	B5 motor flanges		B14 motor flanges		Dynamic efficiency RD	Tooth module [mm]	Ratio code
							-	-	-O 56	-P 63			
280	5	0.18	5	3.3	0.60	17			B-C		82	1.26	09
200	7	0.18	7	2.4	0.44	17			B-C		80	1.44	01
140	10	0.18	10	1.8	0.32	17			B-C		78	1.44	02
93	15	0.18	13	1.4	0.25	19			B-C		73	1.44	03
70	20	0.18	17	1.1	0.20	19			B-C		70	1.09	04
47	30	0.12	15	1.4	0.17	21			B-C		62	1.44	05
35	40	0.12	19	1.1	0.13	20			B-C		57	1.09	06
23	61	0.09	19	1.1	0.10	20			B-C		50	0.72	07
17.5	80	0.06	16	1.0	0.06	16			B-C		48	0.56	08
14	100	0.06*	16	0.5	0.03	8			B-C		40	0.45	10

* Power higher than the maximum one which can be supported by the gearbox. Select according to the torque M_{2R}

Potenza superiore a quella massima sopportabile dal riduttore. Selezionare in base al momento torcente M_{2R}

Motor flanges available
Flange motore disponibili



B) Supplied with reduction bushing
Fornito con bussola di riduzione



B) Available on request without reduction bushing
Disponibile a richiesta senza bussola di riduzione



C) Motor flange holes position
Posizione fori flangia motore

Lubrication

Lubrificazione

Unit N30 is supplied with synthetic oil to assure long life lubrication. Food grade oil is available on request.

See Table 1 for lubrication and recommended quantity.

See Table 2 for possible radial and axial loads on the gearbox.

Il riduttore tipo N30 viene fornito con olio sintetico e lubrificazione tipo "long life". Disponibile a richiesta olio alimentare.

Vedi Tabella 1 per oli e quantità consigliati.

Vedi Tabella 2 per i carichi radiali e assiali applicabili al riduttore.

Oil quantity for all positions:
0.04 L

Quantità olio per tutte le posizioni: 0.04 L

Shell
Omala S4 WE 320

Eni
Teliium VSF 320

Tab. 1

Suggested

Suggerito

Stainless steel protection cap (on request).

Coperchio di protezione in acciaio inox a richiesta.

Kit cod. KN300209

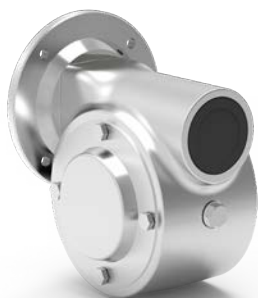

Radial and axial loads

Carichi radiali e assiali

Output shaft

Albero di uscita

n_2 [min ⁻¹]	F_A [N]	F_R [N]
200	120	600
150	140	700
100	160	800
75	180	900
50	200	1000
25	250	1250
15	280	1400

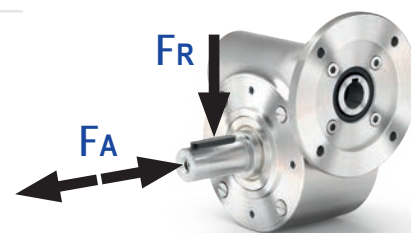

Input shaft

Albero in entrata

n_1 [min ⁻¹]	F_A [N]	F_R [N]
1400	20	100

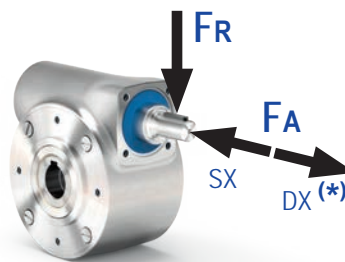

* Strong axial loads in the DX direction are not allowed.

* Non sono consentiti forti carichi assiali con direzione DX

Tab. 2

PN30UNI.. Basic gearbox
Riduttore base

Gearbox weight
Peso riduttore **2.2 kg**

M. flanges	Kit code	øF	A
56B14	KI304046	80	61.5
63B14	KI304045	90	62.5

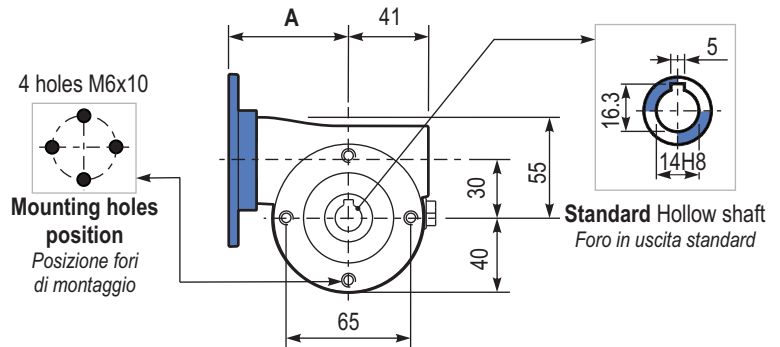
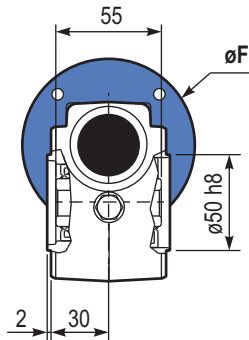

PN30PAI.. Feet
Piedini

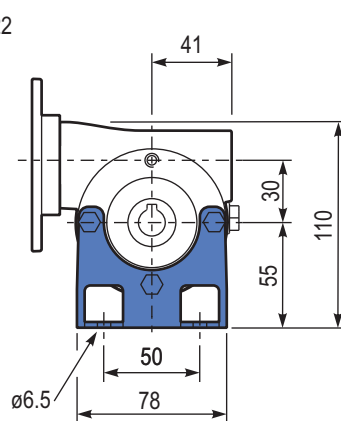
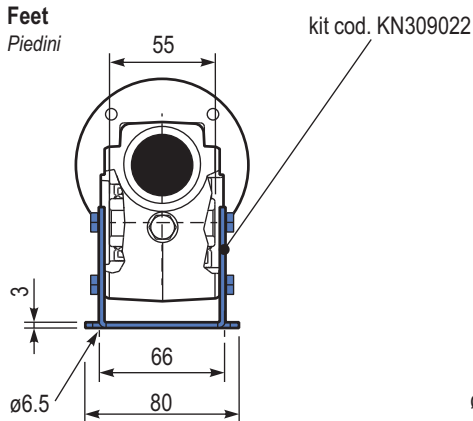

PN30PVI.. Feet
Piedini

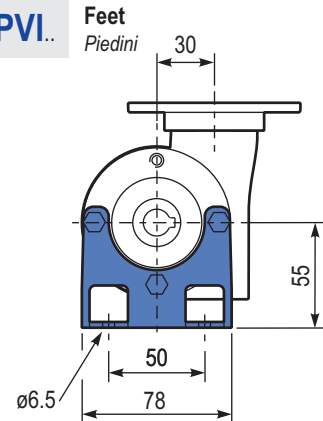

PN30FLL.. Output flange
Flangia uscita

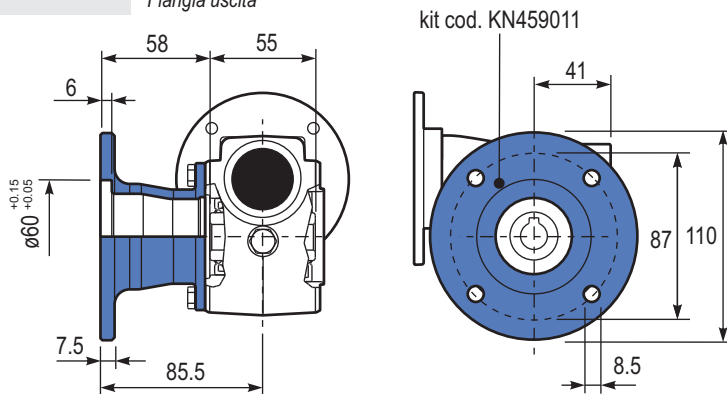

PN30BRI.. Reaction arm
Braccio di reazione

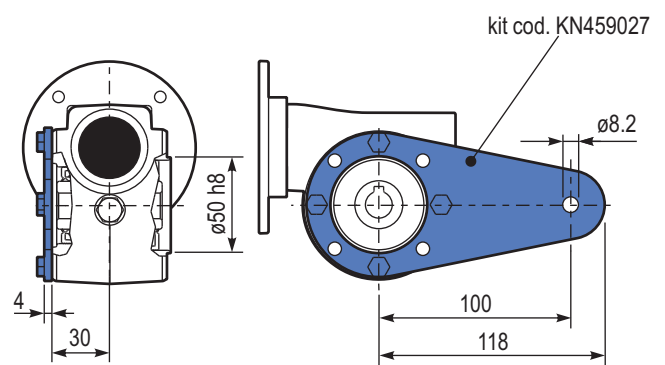

RN30UNI.. Input shaft
Albero in entrata

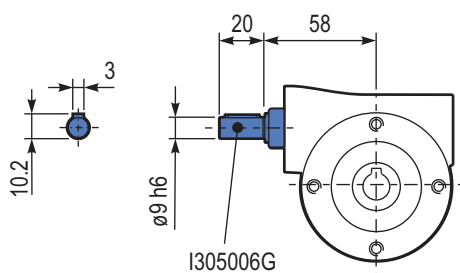

PN30..SMA Single output shaft
Albero semplice in uscita

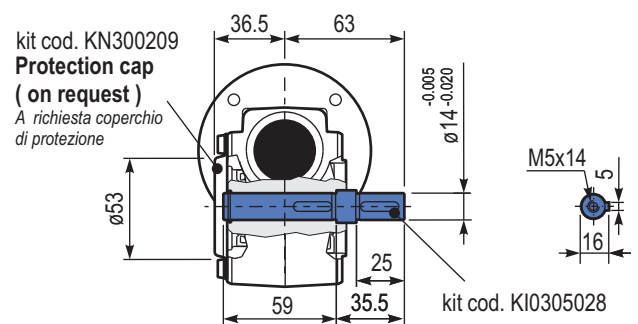

Input speed (n_1) = 1400 min⁻¹

Output speed n_2 [min ⁻¹]	Ratio i	Motor power P_{1M} [kW]	Output torque M_{2M} [Nm]	Service factor $f.s$	Nominal power P_{1R} [kW]	Nominal torque M_{2R} [Nm]	B5 motor flanges		B14 motor flanges		Dynamic efficiency RD	Tooth module [mm]	Ratio code
							-	-	-P 63	-Q 71			
200	7	0.37	14	2.2	0.80	30			B-C		80	2.2	01
140	10	0.37	20	1.5	0.57	30			B-C		79	2.2	02
100	14	0.37	27	1.1	0.41	30			B-C		77	2.4	03
67	21	0.37	36	1.2	0.43	41			B-C		67	1.6	04
50	28	0.25	31	1.3	0.33	41			B-C		65	2.5	05
38	37	0.25	40	1.0	0.26	41			B-C		63	1.8	06
30	46	0.25	46	0.9	0.22	41			B-C		59	1.5	07
23	60	0.18	41	1.0	0.18	41			B-C		56	1.2	08
20	70	0.12	31	1.0	0.12	30			B-C		54	1.0	09
13.7	102	0.12	41	0.7	0.09	29			B-C		49	0.72	10

Motor flanges available
Flange motore disponibili

B) Supplied with reduction bushing
Fornito con bussola di riduzione

B) Available on request without reduction bushing
Disponibile a richiesta senza bussola di riduzione

C) Motor flange holes position
Posizione fori flangia motore

Lubrication

Lubrificazione

Unit N45 is supplied with synthetic oil to assure long life lubrication. Food grade oil is available on request.

See Table 1 for lubrication and recommended quantity.

See Table 2 for possible radial and axial loads on the gearbox.

Il riduttore tipo N45 viene fornito con olio sintetico e lubrificazione tipo "long life". Disponibile a richiesta olio alimentare.

Vedi Tabella 1 per oli e quantità consigliati.

Vedi Tabella 2 per i carichi radiali e assiali applicabili al riduttore.

Oil quantity for all positions:
0.13 L

Quantità olio per tutte le posizioni: 0.13 L

Shell
Omala S4 WE 320

Eni
Telium VSF 320

Tab. 1

Suggested

Suggerito

Stainless steel protection cap (on request).

Coperchio di protezione in acciaio inox a richiesta.

Kit cod. KN300209

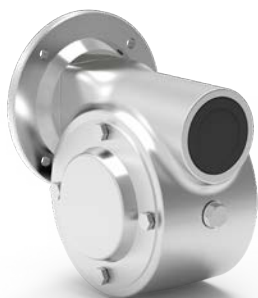

Radial and axial loads

Carichi radiali e assiali

Output shaft

Albero di uscita

n_2 [min ⁻¹]	F_A [N]	F_R [N]
200	180	900
150	200	1000
100	220	1100
75	240	1200
50	260	1400
25	300	1800
15	400	2000

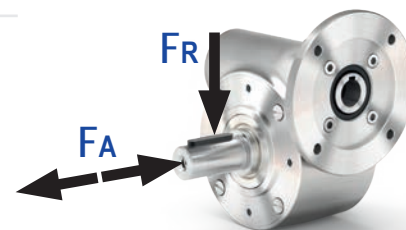

Input shaft

Albero in entrata

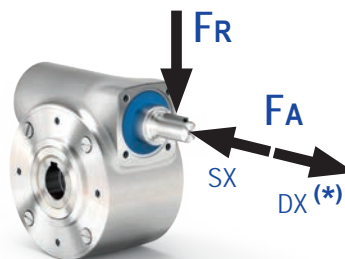

n_1 [min ⁻¹]	F_A [N]	F_R [N]
1400	42	210

* Strong axial loads in the DX direction are not allowed.

* Non sono consentiti forti carichi assiali con direzione DX

Tab. 2

PN45UNI.. Basic gearbox
Riduttore base

M. flanges	Kit code	øF	A
63B14	KI504047	90	73.5
71B14	KI504045	105	71

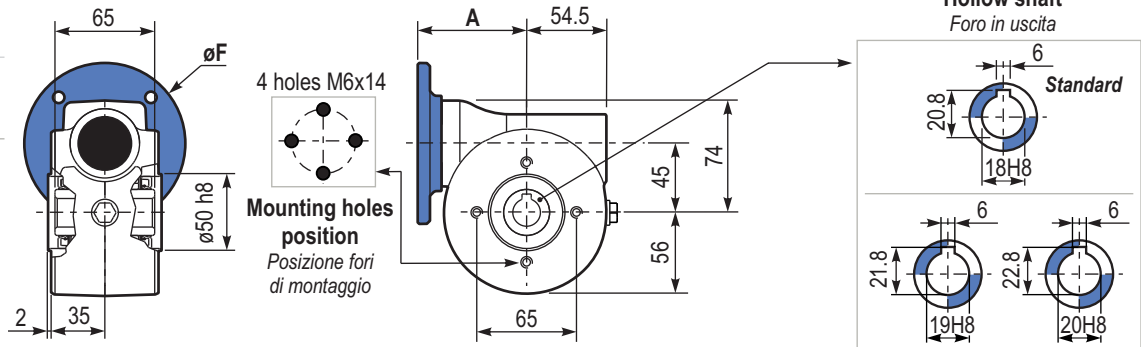

Gearbox weight
Peso riduttore **4.1 kg**

Hollow shaft
Foro in uscita

PN45PAI.. Feet
Piedini

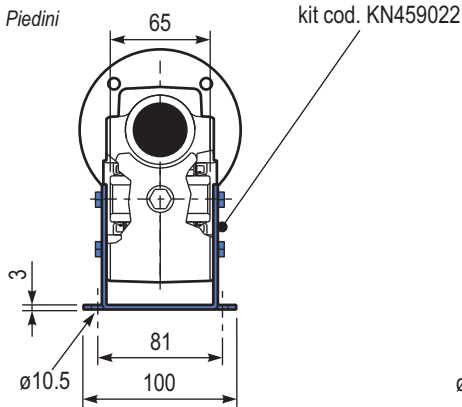

PN45PVI.. Feet
Piedini

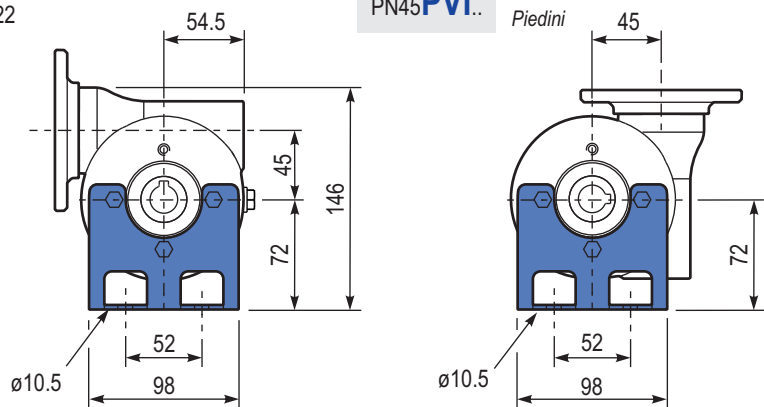

PN45FLL.. Output flange
Flangia uscita

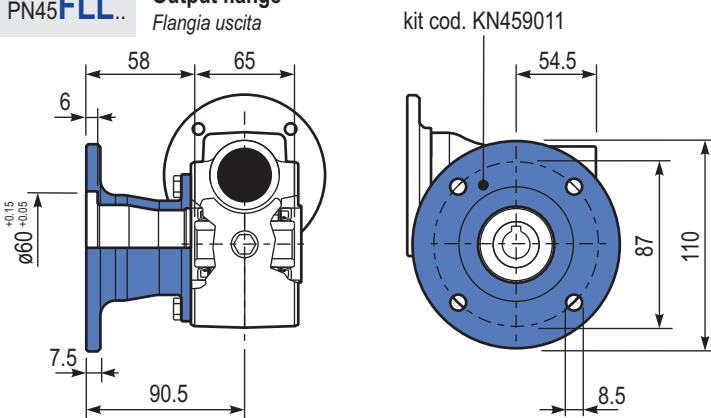

PN45BRI.. Reaction arm
Braccio di reazione

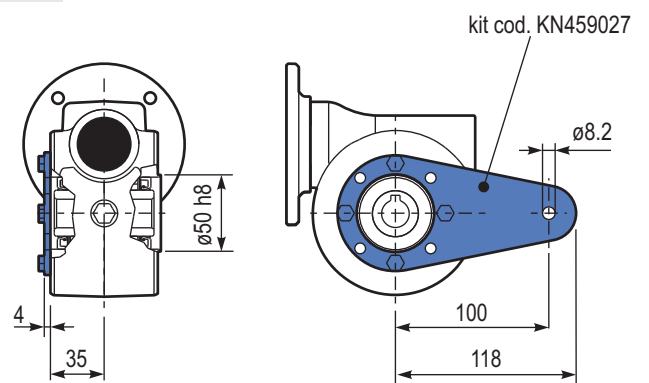

RN45UNI.. Input shaft
Albero in entrata

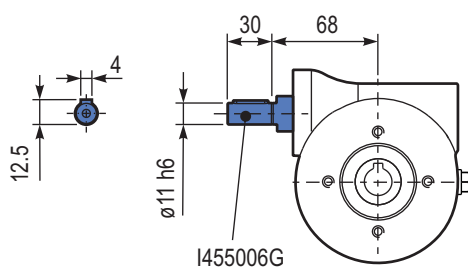

PN45..SMB Single output shaft
Albero semplice in uscita

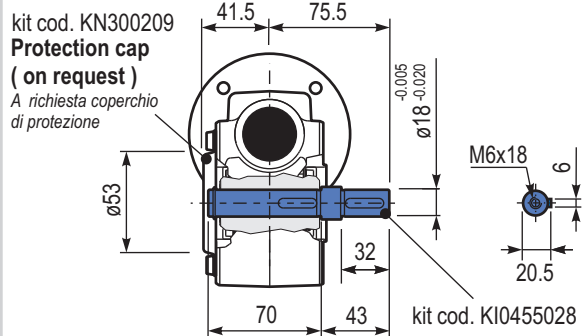

Input speed (n_1) = 1400 min⁻¹

Output speed n_2 [min ⁻¹]	Ratio i	Motor power P_{1M} [kW]	Output torque M_{2M} [Nm]	Service factor $f.s$	Nominal power P_{1R} [kW]	Nominal torque M_{2R} [Nm]	B5 motor flanges			B14 motor flanges			Dynamic efficiency RD	Tooth module [mm]	Ratio code
							-	-	-	-P 63	-Q 71	-R 80			
200	7	0.75	29	1.9	1.5	57				B-C	B		82	2.5	01
140	10	0.75	41	1.5	1.1	62				B-C	B		80	2.4	02
100	14	0.75	57	1.2	0.90	68				B-C	B		79	2.6	03
78	18	0.55	51	1.2	0.67	62				B-C	B		75	2.0	04
54	26	0.55	67	1.0	0.54	66				B-C	B		69	2.7	05
47	30	0.55	79	0.9	0.50	72				B-C	B		70	2.5	12
39	36	0.37	63	1.2	0.43	72				B-C			69	2.1	06
33	43	0.37	72	1.0	0.35	68				B-C			66	1.8	07
28	50	0.25	53	1.2	0.31	66				B-C			62	1.5	13
23	60	0.25	59	1.0	0.26	62				B-C			58	1.3	08
21	68	0.25	66	0.9	0.22	58				B-C			57	1.2	09
17.5	80	0.18	53	1.1	0.19	57				B-C			54	1.0	10
14	100	0.12	41	1.3	0.15	51				B-C			50	0.8	11

Motor flanges available
Flange motore disponibili



B) Supplied with reduction bushing
Fornito con bussola di riduzione



B) Available on request without reduction bushing
Disponibile a richiesta senza bussola di riduzione



C) Motor flange holes position
Posizione fori flangia motore

Lubrication

Lubrificazione

Unit N50 is supplied with synthetic oil to assure long life lubrication. Food grade oil is available on request. See Table 1 for lubrication and recommended quantity. See Table 2 for possible radial and axial loads on the gearbox.

Il riduttore tipo N50 viene fornito con olio sintetico e lubrificazione tipo "long life". Disponibile a richiesta olio alimentare. Vedi Tabella 1 per oli e quantità consigliati. Vedi Tabella 2 per i carichi radiali e assiali applicabili al riduttore.

Oil quantity for all positions:
0.18 L

Quantità olio per tutte le posizioni: 0.18 L

Shell
Omala S4 WE 320

Eni
Telium VSF 320

Tab. 1

Suggested

Suggerito

Stainless steel protection cap (on request).

Coperchio di protezione in acciaio inox a richiesta.

Kit cod. KN500209



Radial and axial loads

Carichi radiali e assiali

Output shaft

Albero di uscita

n_2 [min ⁻¹]	FA [N]	FR [N]
200	240	1200
150	280	1400
100	300	1500
75	340	1700
50	380	1900
25	480	2500
15	560	2800

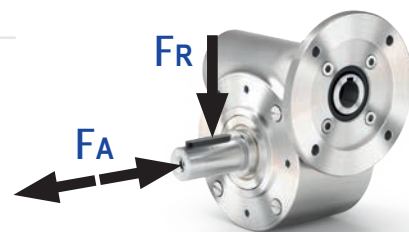

Input shaft

Albero in entrata

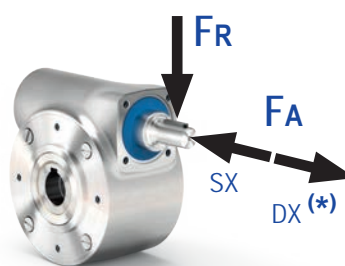

n_1 [min ⁻¹]	FA [N]	FR [N]
1400	76	380

* Strong axial loads in the DX direction are not allowed.
* Non sono consentiti forti carichi assiali con direzione DX

Tab. 2

PN50UNI.. Basic gearbox
Riduttore base

M. flanges	Kit code	øF	A
63B14	KI504047	90	78
71B14	KI504045	105	75.5
80B14	KI504046	120	76

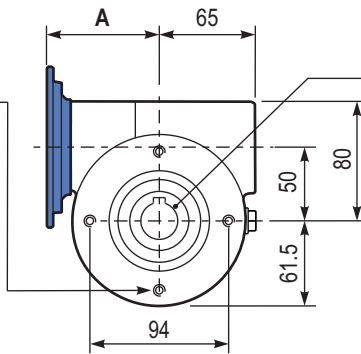
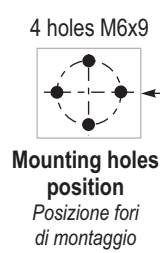
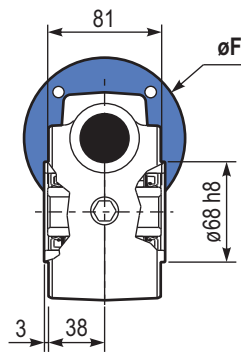

Gearbox weight
Peso riduttore **5.3 kg**

Hollow shaft
Foro in uscita

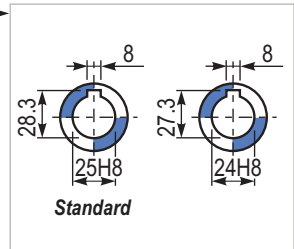

PN50PAI..

Feet
Piedini

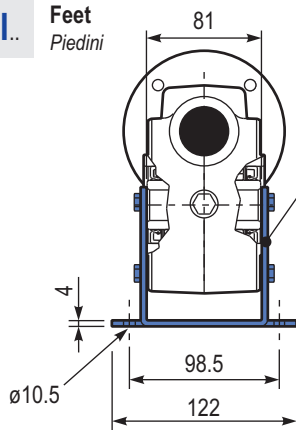

kit cod. KN509022

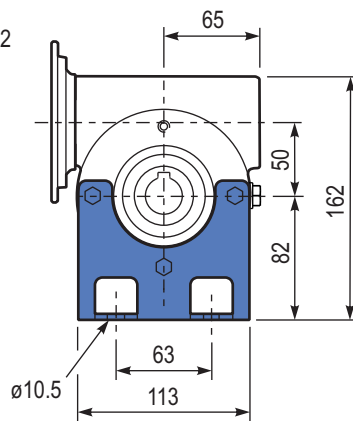

PN50PVI..

Feet
Piedini

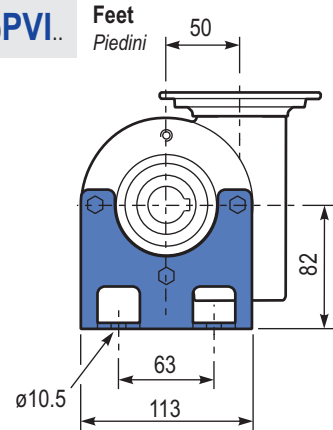

PN50FLL..

Output flange
Flangia uscita

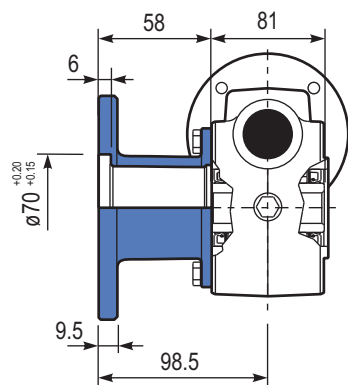

kit cod. KN509011

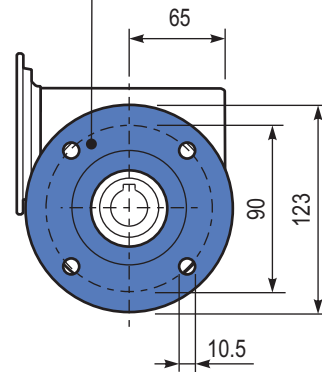

PN50BRI..

Reaction arm
Braccio di reazione

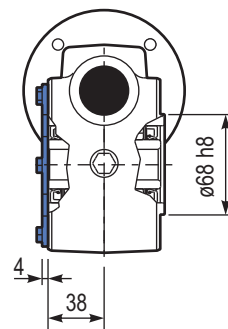

kit cod. KN509027

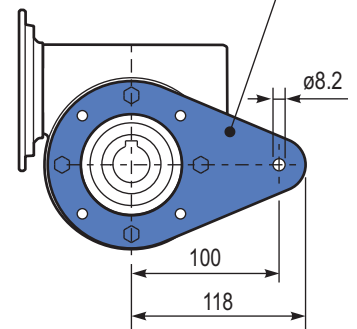

RN50UNI..

Input shaft
Albero in entrata

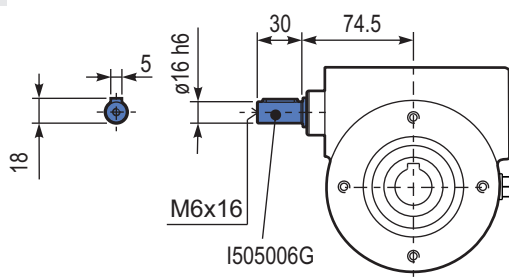

PN50..SMF

Single output shaft
Albero semplice in uscita

kit cod. KN500209
Protection cap
(on request)
A richiesta coperchio di protezione

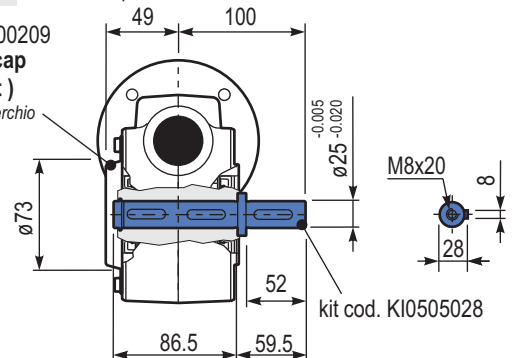

Input speed (n_1) = 1400 min⁻¹

Output speed n_2 [min ⁻¹]	Ratio i	Motor power P_{1M} [kW]	Output torque M_{2M} [Nm]	Service factor $f.s$	Nominal power P_{1R} [kW]	Nominal torque M_{2R} [Nm]	B5 motor flanges			B14 motor flanges			Dynamic efficiency RD	Tooth module [mm]	Ratio code
							-	-	-	-Q	-R	-T			
200	7	1.8	71	1.8	3.2	125	-	-	-	-Q	-R	-T	83	3.1	01
140	10	1.8	99	1.4	2.4	134	-	-	-	71	80	90	81	3.1	02
93	15	1.5	121	1.1	1.7	138	-	-	-	B-C	B-C		79	3.1	03
74	19	1.1	111	1.2	1.4	138	-	-	-	B-C	B-C		78	2.6	04
58	24	1.1	135	1.0	1.2	142	-	-	-	B-C	B-C		75	2.0	05
47	30	1.1	167	0.9	0.96	146	-	-	-	B-C	B-C		74	3.2	06
39	36	0.75	125	1.2	0.88	147	-	-	-	B-C	B-C		68	2.7	07
35	40	0.75	135	1.0	0.78	140	-	-	-	B-C	B-C		66	2.5	13
31	45	0.55	111	1.2	0.67	135	-	-	-	B-C	C		66	2.1	08
23	60	0.55	140	0.9	0.51	130	-	-	-	B-C	C		62	1.6	12
21	67	0.55	151	0.8	0.45	124	-	-	-	B-C	C		60	1.5	09
17.5	80	0.37	115	1.0	0.38	119	-	-	-	B-C	C		57	1.3	10
14.9	94	0.37	123	1.0	0.36	119	-	-	-	B-C	C		52	1.1	11

Motor flanges available
Flange motore disponibili



B) Supplied with reduction bushing
Fornito con bussola di riduzione



B) Available on request without reduction bushing
Disponibile a richiesta senza bussola di riduzione



C) Motor flange holes position
Posizione fori flangia motore

Lubrication

Lubrificazione

Unit N63 is supplied with synthetic oil to assure long life lubrication. Food grade oil is available on request. See Table 1 for lubrication and recommended quantity. See Table 2 for possible radial and axial loads on the gearbox.

Il riduttore tipo N63 viene fornito con olio sintetico e lubrificazione tipo "long life". Disponibile a richiesta olio alimentare. Vedi Tabella 1 per oli e quantità consigliati. Vedi Tabella 2 per i carichi radiali e assiali applicabili al riduttore.

Oil quantity for all positions:
0.45 L

Quantità olio per tutte le posizioni: 0.45 L

Shell
Omala S4 WE 320

Eni
Telium VSF 320

Tab. 1

Suggested

Suggerito

Stainless steel protection cap (on request).

Coperchio di protezione in acciaio inox a richiesta.

Kit cod. KN630209

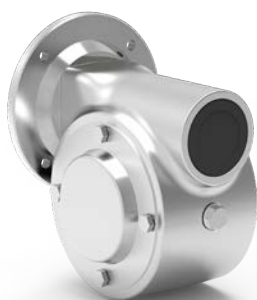

Radial and axial loads

Carichi radiali e assiali

Output shaft

Albero di uscita

n_2 [min ⁻¹]	FA [N]	FR [N]
200	360	1800
150	400	2000
100	460	2300
75	500	2500
50	600	3000
25	700	3800
15	800	4000

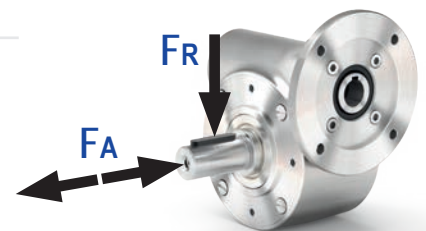

Input shaft

Albero in entrata

n_1 [min ⁻¹]	FA [N]	FR [N]
1400	90	450

* Strong axial loads in the DX direction are not allowed.

* Non sono consentiti forti carichi assiali con direzione DX

Tab. 2

PN63 **UNI..** Basic gearbox
Riduttore base

M. flanges	Kit code	øF	A
71B14	KI634047	105	97
80B14	KI634046	120	99
90B14	KI634041	140	99

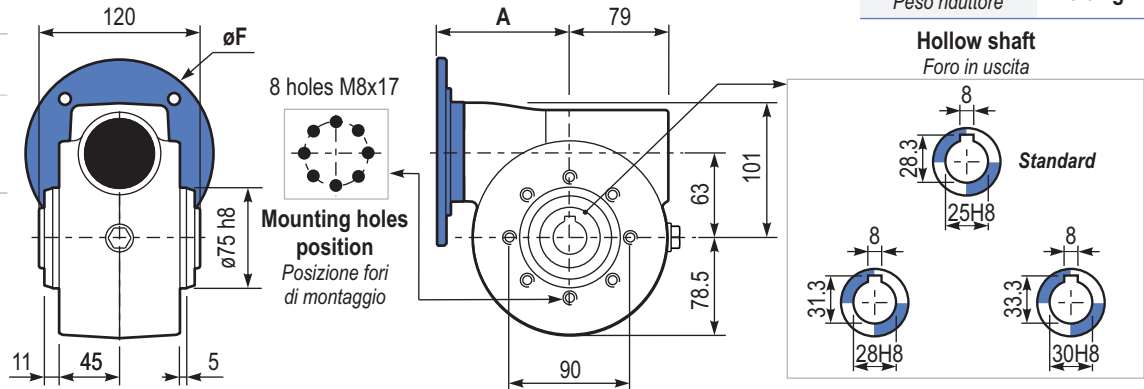

Gearbox weight
Peso riduttore 10.0 kg

PN63 **PAI..** Feet
Piedini

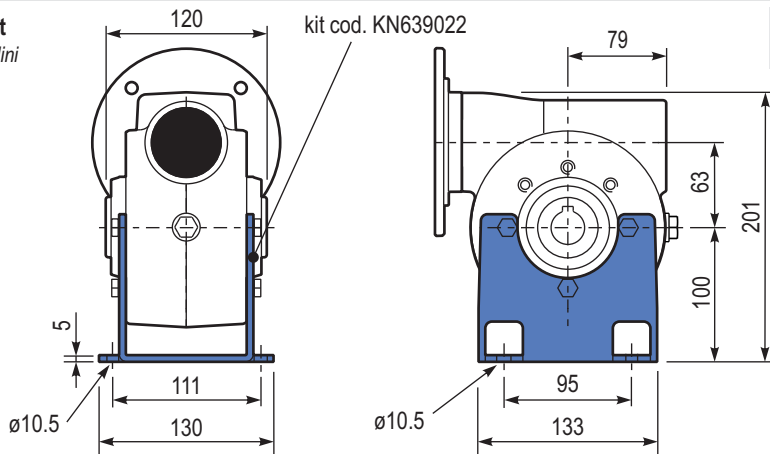

PN63 **PVI..** Feet
Piedini

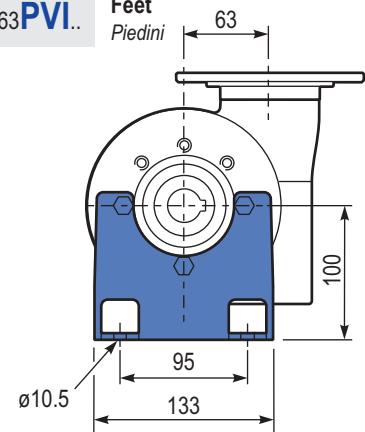

PN63 **FLL..** Output flange
Flangia uscita

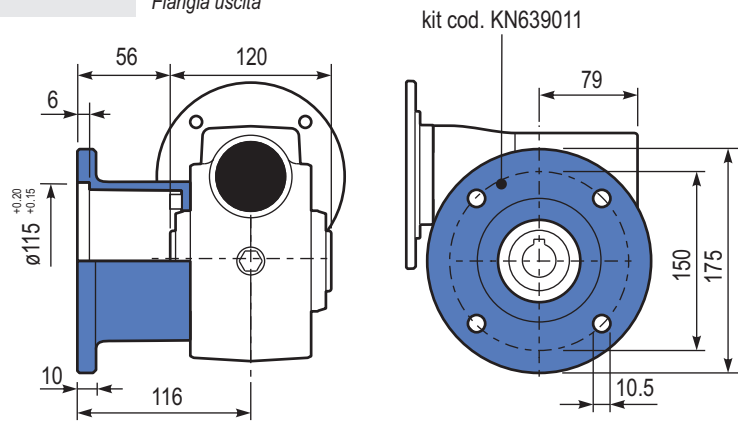

PN63 **BRI..** Reaction arm
Braccio di reazione

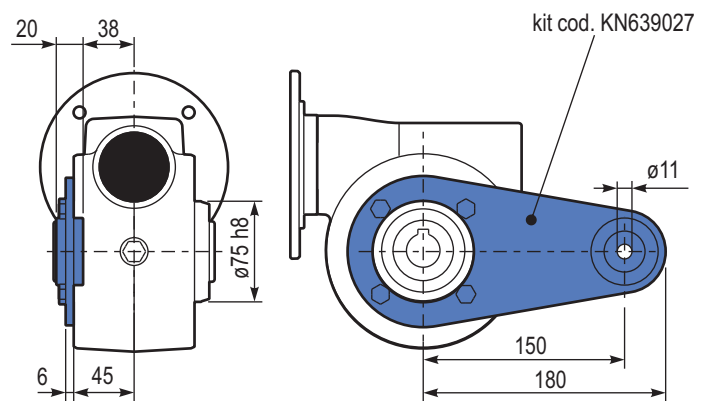

RN63 **UNI..** Input shaft
Albero in entrata

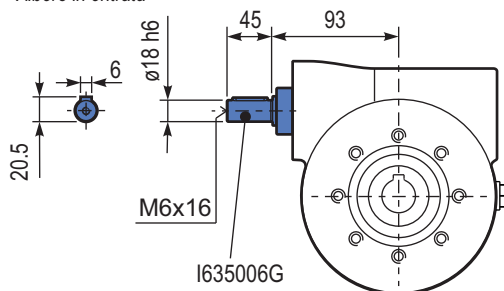

PN63 **SMF** Single output shaft
Albero semplice in uscita

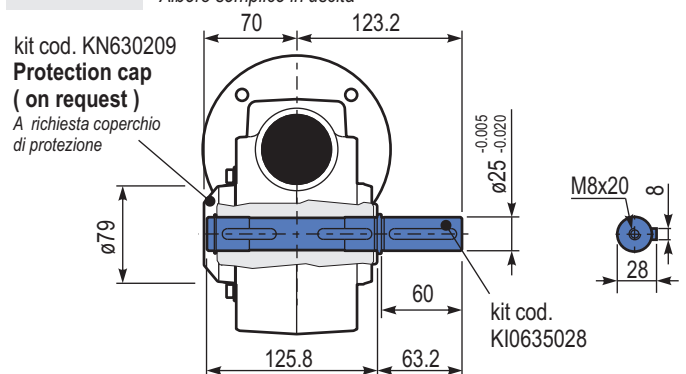

Input speed (n_1) = 1400 min⁻¹

Output speed n_2 [min ⁻¹]	Ratio i	Motor power P_{1M} [kW]	Output torque M_{2M} [Nm]	Service factor $f.s$	Nominal power P_{1R} [kW]	Nominal torque M_{2R} [Nm]	B5 motor flanges			B14 motor flanges			Dynamic efficiency RD	Tooth module [mm]	Ratio code
							-	-	-	-R	-T	-U			
200	7	4.0	168	1.5	6.1	257	-	-	-	B	B	88	4.23	01	
140	10	4.0	218	1.3	5.2	284	-	-	-	B	B	80	4.2	02	
100	14	3.0	223	1.4	4.1	305	-	-	-	B	B	78	4.5	03	
70	20	2.2	237	1.2	2.7	294	-	-	-	B	B	79	3.4	04	
64	22	2.2	258	1.1	2.5	294	-	-	-	B	B	78	3.1	05	
50	28	2.2	315	1.1	2.4	347	-	-	-	B	B	75	4.7	06	
37	38	1.5	276	1.2	1.8	336	-	-	-	B	B	71	3.5	07	
30	46	1.5	320	1.0	1.5	326	-	-	-	B	B	68	3.1	08	
27	52	1.1	258	1.1	1.2	289	-	-	-	B	B	66	2.7	09	
21	67	1.1	327	0.9	0.97	289	-	-	-	B	B	65	2.1	10	
18.9	74	0.75	220	1.2	0.91	268	-	-	-	B	B	58	1.9	11	
14.6	96	0.55	191	1.3	0.70	242	-	-	-	B	B	53	1.5	12	

Motor flanges available
Flange motore disponibili



B) Supplied with reduction bushing
Fornito con bussola di riduzione



B) Available on request without reduction bushing
Disponibile a richiesta senza bussola di riduzione



C) Motor flange holes position
Posizione fori flangia motore

Lubrication

Lubrificazione

Unit N85 is supplied with synthetic oil to assure long life lubrication. Food grade oil is available on request. See Table 1 for lubrication and recommended quantity. See Table 2 for possible radial and axial loads on the gearbox.

Il riduttore tipo N85 viene fornito con olio sintetico e lubrificazione tipo "long life". Disponibile a richiesta olio alimentare. Vedi Tabella 1 per oli e quantità consigliati. Vedi Tabella 2 per i carichi radiali e assiali applicabili al riduttore.

Oil quantity for all positions:
1.0 L

Quantità olio per tutte le posizioni: 1.0 L

Shell
Omala S4 WE 320

Eni
Telium VSF 320

Tab. 1

Suggested

Suggerito

Stainless steel protection cap (on request).

Coperchio di protezione in acciaio inox a richiesta.

Kit cod. KN850209

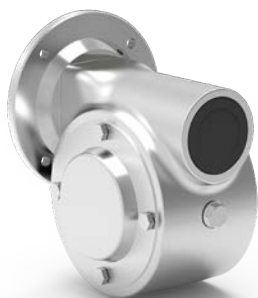

Radial and axial loads

Carichi radiali e assiali

Output shaft

Albero di uscita

n_2 [min ⁻¹]	FA [N]	FR [N]
200	500	2500
150	580	2900
100	600	3000
75	700	3500
50	800	4000
25	1000	5000
15	1160	5800

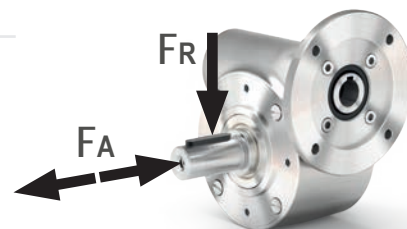

Input shaft

Albero in entrata

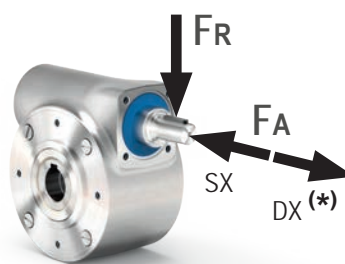

n_1 [min ⁻¹]	FA [N]	FR [N]
1400	130	650

* Strong axial loads in the DX direction are not allowed.

* Non sono consentiti forti carichi assiali con direzione DX

Tab. 2

PN85UNI.. Basic gearbox
Riduttore base

Gearbox weight
Peso riduttore 21.0 kg

M. flanges	Kit code	øF	A
80B14	KI854046	120	118
90B14	KI854045	140	118
100/112B14	KI854041	160	127

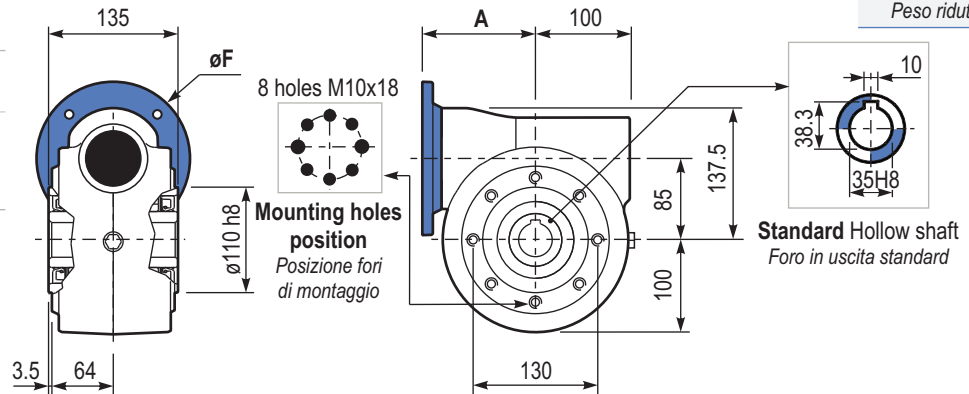

PN85PAI.. Feet
Piedini

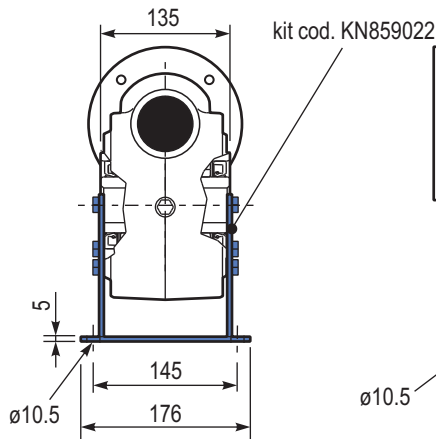

PN85PVI.. Feet
Piedini

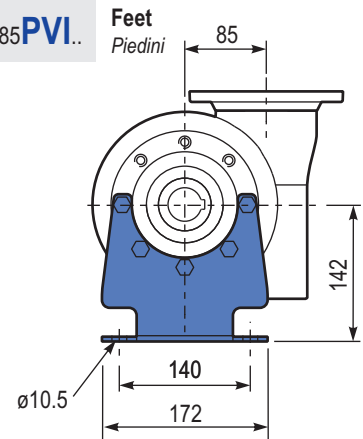

PN85FLL.. Output flange
Flangia uscita

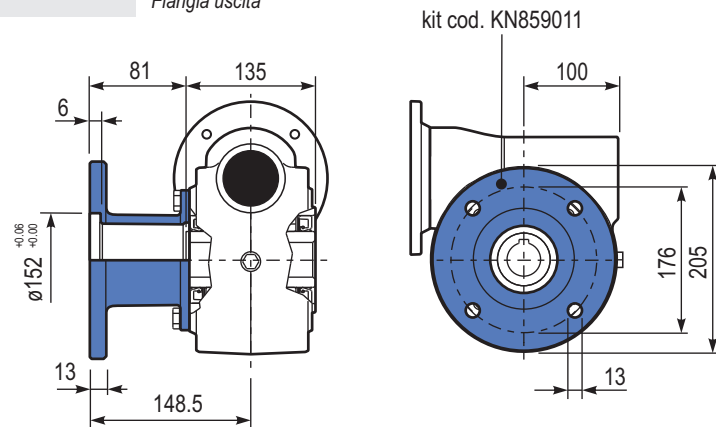

PN85BRI.. Reaction arm
Braccio di reazione

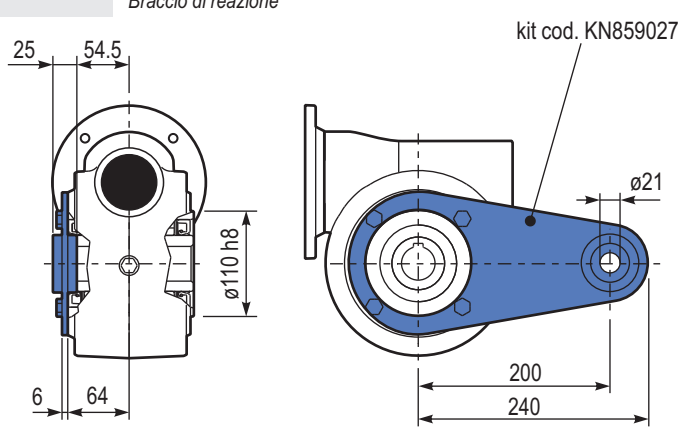

RN85UNI.. Input shaft
Albero in entrata

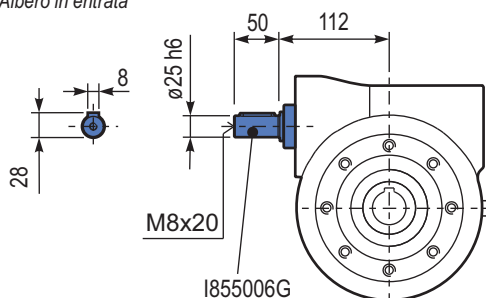

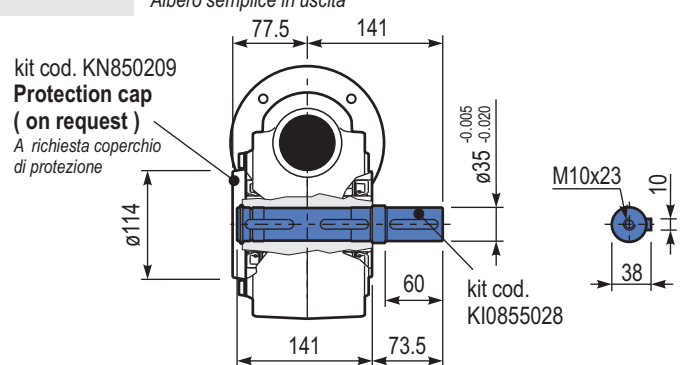

PN85..SMK Single output shaft
Albero semplice in uscita



N45 Ratios/Rating

Rapporti/Selezione N45

Ratio	Max output torque ** M_{2R} [Nm]	Tooth module  [mm]	Standard input bore	Ratio code 
i _a				
7	35	2.2	ø14	01
10	35	2.2	ø14	02
14	35	2.4	ø14	03
21	47	1.6	ø14	04
28	47	2.5	ø14	05
37	47	1.8	ø14	06
46	47	1.5	ø14	07
60	47	1.2	ø14	08
70	35	1.0	ø14	09
102	34	0.72	ø14	10

N45 weight
Peso N45

4.10 kg

211N Ratios/Power

Rapporti/potenza 211N

Ratio	Max input power ** P_{1M} [kW]	Standard output shaft	Ratios code 
i _b			
2.05	0.37	ø14	01
2.35	0.37	ø14	02
2.80	0.37	ø14	03
3.38	0.37	ø14	04
4.70	0.37	ø14	05
6.22	0.37	ø14	06
8.29	0.37	ø14	07
9.83	0.25	ø14	08

211N weight
Peso 211N

2.50 kg



211N Motor flanges

Flange motore 211N

	kit code	g6	A
63B14	KI504047	90	99.5
71B14	KI504045	105	97

How to connect N45+211N

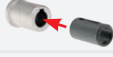
Come collegare N45 + 211N

Worm gearbox		Ratio multiplier	Connection kit	
Standard input bore	Output shaft	211N	With standard input bore	With coupling
N45	øN	211N		
Ratios from 1/7 ÷ 1/102	ø14	ø14	Reduction bushing is not necessary	KB14P

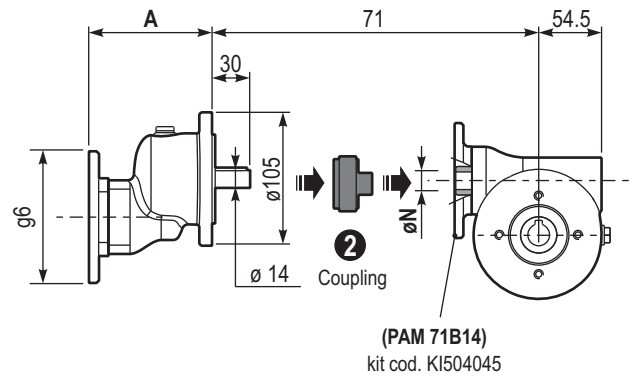
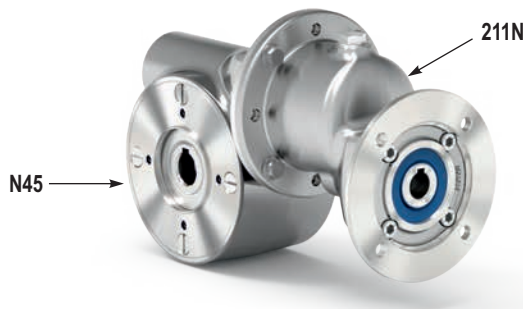

Ratios range: from 1/14 to 1/1003

Range rapporti: da 1/14 a 1/1003

Lubrication

Lubrificazione

Unit N45+211N is supplied with synthetic oil to assure long life lubrication. Food grade oil is available on request. See Table 1 for lubrication and recommended quantity.

Il riduttore tipo N45+211N viene fornito con olio sintetico e lubrificazione tipo "long life".

Disponibile a richiesta olio alimentare.

Vedi Tabella 1 per oli e quantità consigliati.

For all details on lubrication and plugs check our website.

Per maggiori dettagli su lubrificazione e tappi olio vedi il nostro sito web.

N45: 0.13 L	SHELL: Omala S4 WE 320	ENI: Telium VSF 320
211N: 0.05 L	SHELL: Omala S4 WE 320	ENI: Telium VSF 320

tab. 1

Calculate total ratio and output speed

Calcola il rapporto totale e la velocità di uscita

Ratios range: from 1/14 to 1/1003

Range rapporti: da 1/14 a 1/1003

$$i_{TOT} = i_a \cdot i_b$$

Ex.: 1/102 x 1/9.83 = 1/1003 (Max ratio)

Output speed (n₂)

Velocità di uscita

$$n_2 = n_1 : i_{TOT}$$

Ex.: 1448 : 1003 = 1.44 rpm

i_a : N45 ratio - Rapporto N45

i_b : 211N ratio - Rapporto 211N

** Make sure input power for 211N and output torque for N45 is as catalogue ratios.

** Prestare attenzione a selezionare la potenza in entrata del 211N ed il momento torcente del N45 secondo le tabelle del catalogo.

n₁ Input speed

Velocità di ingresso



VFN series with ratio multiplier RCN series

N50 211N

Riduttori a vite senza fine serie VFN in acciaio inox con precoppia serie RCN

N50 Ratios/Rating

Rapporti/Selezione N50

Ratio	Max output torque $**M_{2R}$ [Nm]	Tooth module  [mm]	Standard input bore	Ratio code 
i_a				
7	65	2.5	∅19	01
10	71	2.4	∅19	02
14	78	2.6	∅19	03
18	71	2.0	∅19	04
26	76	2.7	∅19	05
30	83	2.5	∅19	12
36	83	2.1	∅14	06
43	78	1.8	∅14	07
50	76	1.5	∅14	13
60	71	1.3	∅14	08
68	66	1.2	∅14	09
80	65	1.0	∅14	10
100	59	0.8	∅14	11

N50 weight
Peso N50

5.30 kg

211N Ratios/Power

Rapporti/potenza 211N

Ratio	Max input power $**P_{1M}$ [kW]	Output shaft	Ratios code 
i_b			
2.05	0.37	∅14	01
2.35	0.37	∅14	02
2.80	0.37	∅14	03
3.38	0.37	∅14	04
4.70	0.37	∅14	05
6.22	0.37	∅14	06
8.29	0.37	∅14	07
9.83	0.25	∅14	08

211N weight
Peso 211N

2.50 kg



211N Motor flanges

Flange motore 211N

	kit code	g6	A
63B14	KI504047	90	99.5
71B14	KI504045	105	97

How to connect N50+211N

Come collegare N50 + 211N

Worm gearbox		Ratio multiplier	Connection kit	
Standard input bore	Output shaft	211N	With standard input bore	With coupling
N50	∅N	211N		
Ratios from 1/7 ÷ 1/30	∅19	∅14	KBR14/19	KC14P
Ratios from 1/36 ÷ 1/100	∅14		Reduction bushing is not necessary	

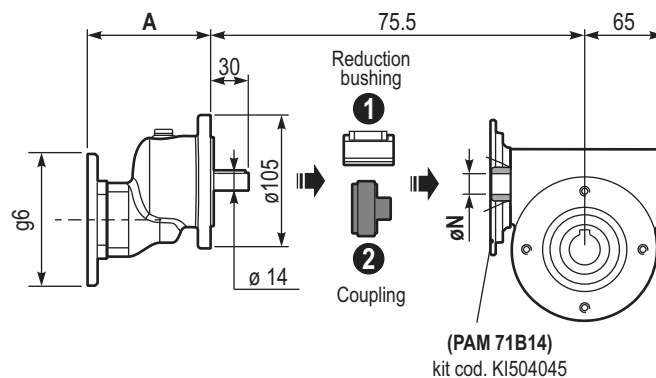

Ratios range: from 1/14 to 1/983

Range rapporti: da 1/14 a 1/983

Lubrication

Lubrificazione

Unit N50+211N is supplied with synthetic oil to assure long life lubrication. Food grade oil is available on request. See Table 1 for lubrication and recommended quantity.

Il riduttore tipo N50+211N viene fornito con olio sintetico e lubrificazione tipo "long life".

Disponibile a richiesta olio alimentare.

Vedi Tabella 1 per oli e quantità consigliati.

For all details on lubrication and plugs check our website.

Per maggiori dettagli su lubrificazione e tappi olio vedi il nostro sito web.

N50: 0.18 L	SHELL: Omala S4 WE 320	ENI: Telium VSF 320
211N: 0.05 L	SHELL: Omala S4 WE 320	ENI: Telium VSF 320

tab. 1

Calculate total ratio and output speed

Calcola il rapporto totale e la velocità di uscita

Ratios range: from 1/14 to 1/983

Range rapporti: da 1/14 a 1/983

$$i_{TOT} = i_a \cdot i_b$$

Ex.: $1/100 \times 1/9.83 = 1/983$ (Max ratio)

Output speed (n_2)

Velocità di uscita

$$n_2 = n_1 : i_{TOT}$$

Ex.: $1448 : 983 = 1.47$ rpm

i_a : N50 ratio - Rapporto N50

i_b : 211N ratio - Rapporto 211N

** Make sure input power for 211N and output torque for N50 is as catalogue ratios.

** Prestare attenzione a selezionare la potenza in entrata del 211N ed il momento torcente del N50 secondo le tabelle del catalogo.

n_1 Input speed

Velocità di ingresso



N63 211N

VFN series with ratio multiplier RCN series

Riduttori a vite senza fine serie VFN in acciaio inox con precoppia serie RCN

N63 Ratios/Rating

Rapporti/Selezione N63

Ratio	Max output torque ** M_{2R} [Nm]	Tooth module  [mm]	Standard input bore	Ratio code 
i _a				
7	144	3.1	ø24	01
10	155	3.1	ø24	02
15	158	3.1	ø24	03
19	158	2.6	ø24	04
24	163	2.0	ø24	05
30	168	3.2	ø24	06
36	169	2.7	ø24	07
40	161	2.5	ø24	13
45	156	2.1	ø19	08
60	150	1.6	ø19	12
67	142	1.5	ø19	09
80	136	1.3	ø19	10
94	136	1.1	ø19	11

N63 weight
Peso N63

10.00 kg

211N Ratios/Power

Rapporti/potenza 211N

Ratio	Max input power ** P_{1M} [kW]	Standard output shaft	Ratios code 
i _b			
2.05	0.37	ø14	01
2.35	0.37	ø14	02
2.80	0.37	ø14	03
3.38	0.37	ø14	04
4.70	0.37	ø14	05
6.22	0.37	ø14	06
8.29	0.37	ø14	07
9.83	0.25	ø14	08

211N weight
Peso 211N

2.50 kg

211N Motor flanges

Flange motore 211N

	kit code	g6	A
63B14	KI504047	90	99.5
71B14	KI504045	105	97

How to connect N63+211N

Come collegare N63 + 211N

Worm gearbox	Ratio multiplier	Connection kit	
		With standard input bore	With coupling
Standard input bore	Output shaft		
N63	øN	211N	
Ratios from 1/7 ÷ 1/40	ø24	ø14	KBR14/24
Ratios from 1/45 ÷ 1/94	ø19		KD14P

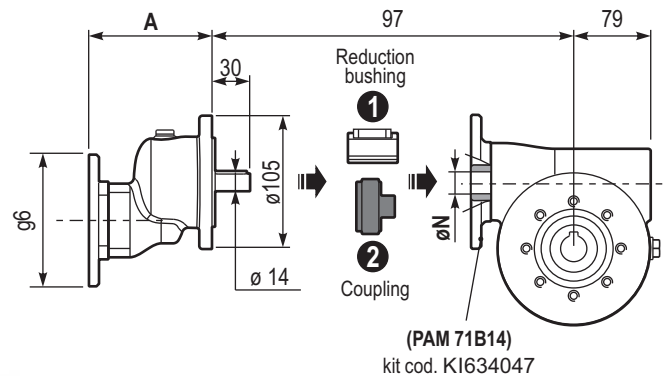

Ratios range: from 1/14 to 1/924

Range rapporti: da 1/14 a 1/924

Lubrication

Lubrificazione

Unit N63+211N is supplied with synthetic oil to assure long life lubrication. Food grade oil is available on request. See Table 1 for lubrication and recommended quantity.

Il riduttore tipo N63+211N viene fornito con olio sintetico e lubrificazione tipo "long life".

Disponibile a richiesta olio alimentare. Vedi Tabella 1 per oli e quantità consigliati.

For all details on lubrication and plugs check our website.

Per maggiori dettagli su lubrificazione e tappi olio vedi il nostro sito web.

N63: 0.45 L	SHELL: Omala S4 WE 320	ENI: Telium VSF 320
211N: 0.05 L	SHELL: Omala S4 WE 320	ENI: Telium VSF 320

Calculate total ratio and output speed

Calcola il rapporto totale e la velocità di uscita

Ratios range: from 1/14 to 1/924

Range rapporti: da 1/14 a 1/924

$$i_{TOT} = i_a \cdot i_b$$

Ex.: 1/94 x 1/9.83 = 1/924 (Max ratio)

Output speed (n₂)

Velocità di uscita

$$n_2 = n_1 : i_{TOT}$$

Ex.: 1448 : 924 = 1.57 rpm

i_a : N63 ratio - Rapporto N63

i_b : 211N ratio - Rapporto 211N

** Make sure input power for 211N and output torque for N63 is as catalogue ratios.

** Prestare attenzione a selezionare la potenza in entrata del 211N ed il momento torcente del N63 secondo le tabelle del catalogo.

n₁ Input speed

Velocità di ingresso



VFN series with ratio multiplier RCN series

N85 211N

Riduttori a vite senza fine serie VFN in acciaio inox con precoppia serie RCN

N85 Ratios/Rating

Rapporti/Selezione N85



Ratio	Max output torque	Tooth module	Standard input bore	Ratio code
i_a	** M_{2R} [Nm]	 [mm]		
7	296	4.23	ø28	01
10	326	4.2	ø28	02
14	350	4.5	ø28	03
20	338	3.4	ø28	04
22	338	3.1	ø28	05
28	398	4.7	ø28	06
38	386	3.5	ø24	07
46	374	3.1	ø24	08
52	332	2.7	ø24	09
67	332	2.1	ø24	10
74	308	1.9	ø24	11
96	278	1.5	ø24	12

N85 weight
Peso N85

21.00 kg

211N Ratios/Power

Rapporti/potenza 211N

Ratio	Max input power	Output shaft	Ratios code
i_b	** P_{1M} [kW]		
2.05	0.37	ø14	01
2.35	0.37	ø14	02
2.80	0.37	ø14	03
3.38	0.37	ø14	04
4.70	0.37	ø14	05
6.22	0.37	ø14	06
8.29	0.37	ø14	07
9.83	0.25	ø14	08

211N weight
Peso 211N

2.50 kg

211N Motor flanges

Flange motore 211N

	kit code	g6	A
63B14	KI504047	90	99.5
71B14	KI504045	105	97

How to connect N85+211N

Come collegare N85 + 211N

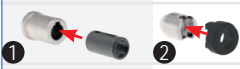
Worm gearbox	Ratio multiplier	Connection kit	
		With standard input bore	With coupling
Standard input bore	Output shaft		
N85	øN	211N	
Ratios from 1/7 ÷ 1/28	ø28	ø14	KBR14/28
Ratios from 1/38 ÷ 1/96	ø24		KBR14/24
			KE14P



Ratios range: from 1/14 to 1/944

Range rapporti: da 1/14 a 1/924

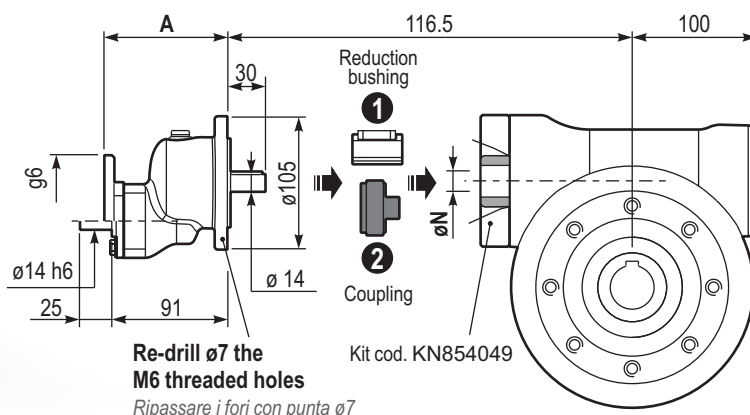

Lubrication

Lubrificazione

Unit N85+211N is supplied with synthetic oil to assure long life lubrication. Food grade oil is available on request. See Table 1 for lubrication and recommended quantity.

Il riduttore tipo N85+211N viene fornito con olio sintetico e lubrificazione tipo "long life".

Disponibile a richiesta olio alimentare. Vedi Tabella 1 per oli e quantità consigliati.

For all details on lubrication and plugs check our website.

Per maggiori dettagli su lubrificazione e tappi olio vedi il nostro sito web.

N85: 1.00 L	SHELL: Omala S4 WE 320	ENI: Telium VSF 320
211N: 0.05 L	SHELL: Omala S4 WE 320	ENI: Telium VSF 320

tab. 1

Calculate total ratio and output speed

Calcola il rapporto totale e la velocità di uscita

Ratios range: from 1/14 to 1/944

Range rapporti: da 1/14 a 1/924

$$i_{TOT} = i_a \cdot i_b$$

Ex.: $1/96 \times 1/9.83 = 1/944$ (Max ratio)

i_a : N85 ratio - Rapporto N85

i_b : 211N ratio - Rapporto 211N

** Make sure input power for 211N and output torque for N85 is as catalogue ratios.

** Prestare attenzione a selezionare la potenza in entrata del 211N ed il momento torcente del N85 secondo le tabelle del catalogo.

Output speed (n_2)

Velocità di uscita

$$n_2 = n_1 : i_{TOT}$$

Ex.: $1448 : 944 = 1.53$ rpm

n_1 Input speed

Velocità di ingresso



RCN series Full stainless steel ratio multipliers

Riduttori ad uno stadio completamente in acciaio inox

Section **4**
Sezione 4

AISI 316L

IP66





CE

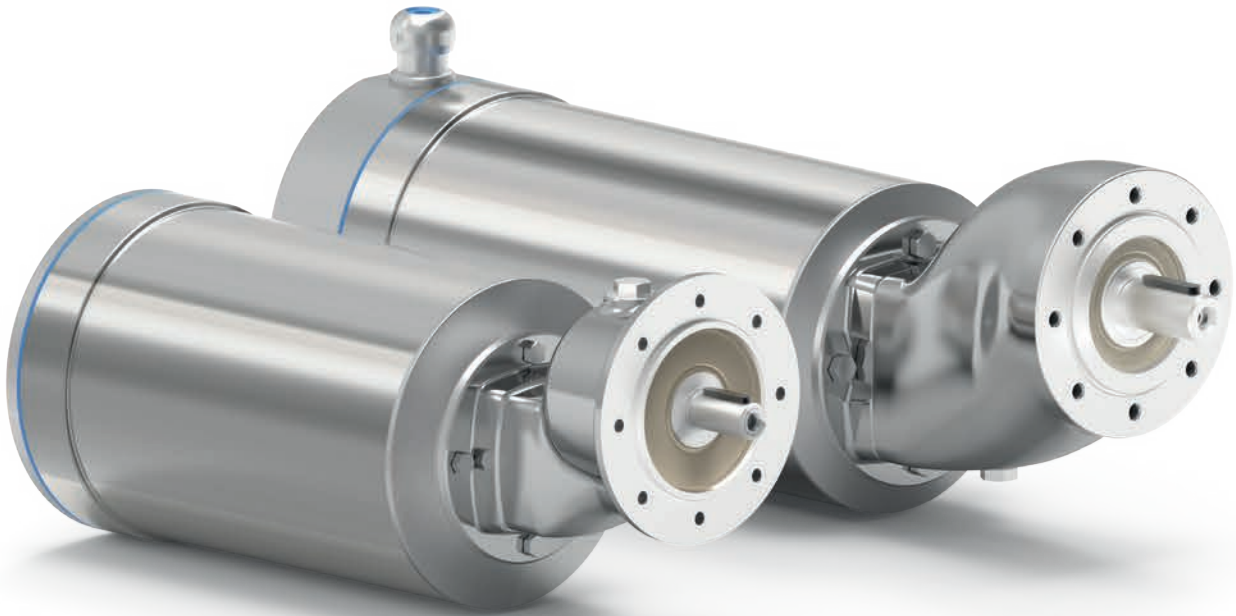











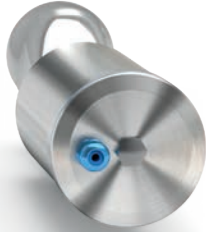

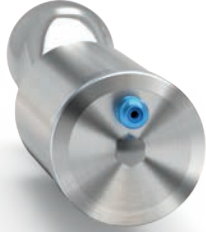
On req.
A rich.

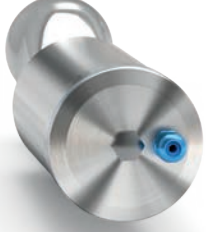



How to order *Codifica*

P	411N	-F	1.57	C
Type <i>Tipo</i>	Size <i>Grandezza</i>	Mounting <i>Montaggio</i>	Ratio <i>Rapporto</i>	Output shaft <i>Albero lento</i>
P 	211N 411N	-F 	See technical data table <i>Vedi tabelle dati tecnici</i>	→ Standard 
M 		211N		S → ø14
B 		411N		C → ø19

I	-T	B3	ST	For M type specify terminal box position
Output flange <i>Flangia uscita</i>	Motor size <i>Grandezza motore</i>	Mounting position <i>Posizione di montaggio</i>	Input bore <i>Foro entrata</i>	<i>Per tipo M specificare posizione morsettiera</i>
 <p>I → ø105</p>	Motor flanges <i>Flange motore</i>	B3 	ST Standard bore <i>Foro standard</i>	A 
		B6 		B 
	IEC B14	B7 		C 
	-P → 63 B14 (ø90) -Q → 71 B14 (ø105) -R → 80 B14 (ø120) -T → 90 B14 (ø140)	B8 		D 
	Without flange <i>Senza flangia</i>	V5 		
		V6 		
	211N			
	-Z → ø9 (IEC 56) -0 → ø11 (IEC 63) -1 → ø14 (IEC 71)			
	411N			
	-1 → ø14 (IEC 71)			
-2 → ø19 (IEC 80)				
-3 → ø24 (IEC 90)				

The dynamic efficiency is **0.98** for all ratios

Input speed (n_1) = 1400 min⁻¹

Output speed n_2 [min ⁻¹]	Ratio i	Motor power P_{1M} [kW]	Output torque M_{2M} [Nm]	Service factor $f.s$	Nominal power P_{1R} [kW]	Nominal torque M_{2R} [Nm]	B5 motor flanges		B14 motor flanges			Output shaft  standard ø14	Ratios code 
							-	-	-P 63	-Q 71			
682	2.05	0.37	5	2.0	0.73	10			C		1939	01	
595	2.35	0.37	6	2.1	0.76	12			C		1740	02	
500	2.80	0.37	7	2.0	0.75	14			C		1542	03	
414	3.38	0.37	8	2.0	0.75	17			C		1344	04	
298	4.70	0.37	12	1.7	0.64	20			C		1047	05	
225	6.22	0.37	15	1.5	0.55	23			C		956	06	
169	8.29	0.37	20	1.0	0.36	20			C		758	07	
142	9.83	0.25	16	1.0	0.24	16			C		659	08	

Motor flanges available
Flange motore disponibili

 **B) Supplied with reduction bushing**
Fornito con bussola di riduzione

B) Available on request without reduction bushing
Disponibile a richiesta senza bussola di riduzione

 **C) Motor flange holes position**
Posizione fori flangia motore

Lubrication

Lubrificazione

Unit 211N is supplied with synthetic oil to assure long life lubrication.
Food grade oil is available on request.
See Table 1 for lubrication and recommended quantity.
See Table 2 for possible radial and axial loads on the gearbox.

*Il riduttore tipo 211N viene fornito con olio sintetico e lubrificazione tipo "long life".
Disponibile a richiesta olio alimentare.
Vedi Tabella 1 per oli e quantità consigliati.
Vedi Tabella 2 per i carichi radiali e assiali applicabili al riduttore.*

Oil quantity for all positions: 0.05 L Quantità olio per tutte le posizioni: 0.05 L	Shell Omala S4 WE 320	Eni Telium VSF 320

Radial and axial loads

Carichi radiali e assiali

Output shaft

Albero di uscita

n_2 [min ⁻¹]	F_A [N]	F_R [N]
700	101	504
600	120	600
400	138	696
300	151	756
200	175	876
140	192	960

$$F_{eq} = F_R \cdot \frac{34.5}{X + 19.5}$$

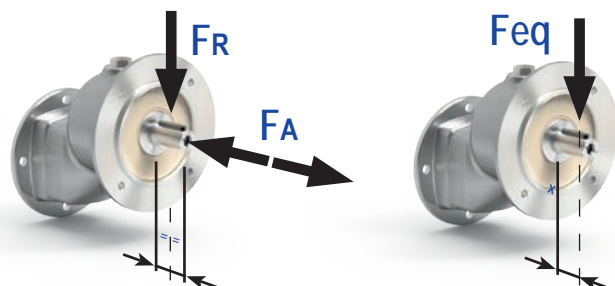

Tab. 1

Tab. 2

P211N-F... **Basic gearbox**
Riduttore base

Gearbox weight
peso riduttore **2.50 kg**

Input flanges / flange di entrata

	Kit code	k1	g6
63 B14	KI504047	99.5	90
71 B14	KI504045	97	105

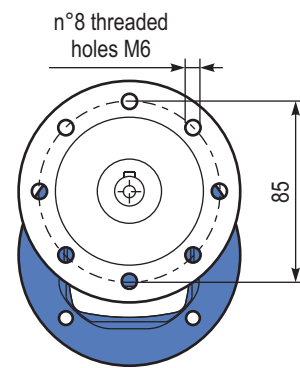
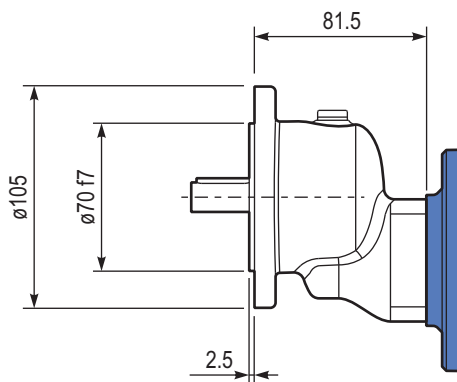
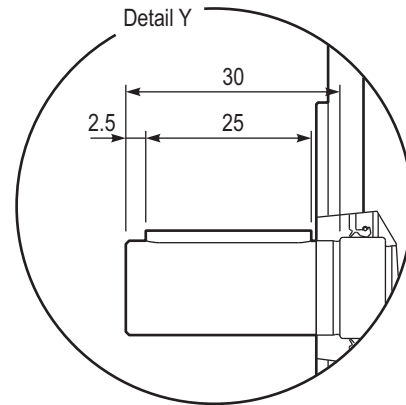
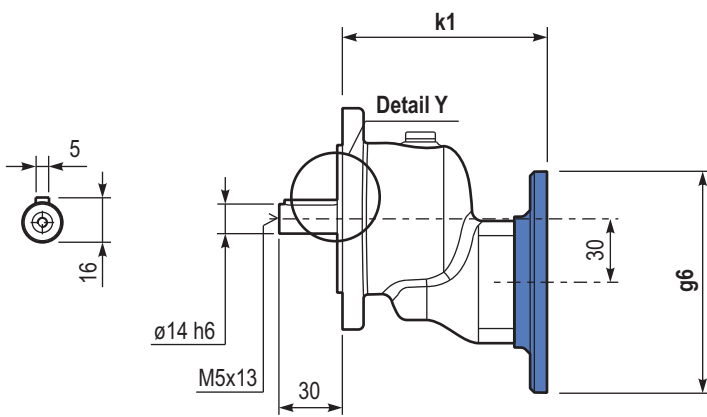

The dynamic efficiency is **0.98** for all ratios

Input speed (n_1) = 1400 min⁻¹

Output speed n_2 [min ⁻¹]	Ratio i	Motor power P_{1M} [kW]	Output torque M_{2M} [Nm]	Service factor $f.s$	Nominal power P_{1R} [kW]	Nominal torque M_{2R} [Nm]	B5 motor flanges		B14 motor flanges			Output shaft 	Ratios code
							-	-	-Q	-R	-T		
							-	-	71	80	90		
891	1.57	1.5	16	1.3	1.9	20			C	C		2844	01
493	2.84	1.5	28	1.2	1.8	35			C	C		1954	02
425	3.29	1.5	33	1.2	1.7	38			C	C		1756	03
362	3.87	1.5	39	1.0	1.5	40			C	C		1558	04
303	4.62	1.5	46	1.0	1.5	47			C	C	standard ø19	1360	05
222	6.30	1.1	46	1.0	1.1	46			C	C		1063	06
170	8.22	0.55	30	1.3	0.69	38			C	C		974	07
129	10.86	0.37	27	1.0	0.39	28			C	C		776	08

Motor flanges available
Flange motore disponibili

B) Supplied with reduction bushing
Fornito con bussola di riduzione

B) Available on request without reduction bushing
Disponibile a richiesta senza bussola di riduzione

C) Motor flange holes position
Posizione fori flangia motore

Lubrication

Lubrificazione

Unit 411N is supplied with synthetic oil to assure long life lubrication.

Food grade oil is available on request.

See Table 1 for lubrication and recommended quantity.

See Table 2 for possible radial and axial loads on the gearbox.

Il riduttore tipo 411N viene fornito con olio sintetico e lubrificazione tipo "long life".

Disponibile a richiesta olio alimentare.

Vedi Tabella 1 per oli e quantità consigliati.

Vedi Tabella 2 per i carichi radiali e assiali applicabili al riduttore.

Oil quantity for all positions:
0.14 L

Quantità olio per tutte le posizioni: 0.14 L

Shell
Omala S4 WE 320

Eni
Telium VSF 320

Radial and axial loads

Carichi radiali e assiali

Output shaft

Albero di uscita

n_2 [min ⁻¹]	FA [N]	FR [N]
700	182	910
600	200	1000
400	230	1150
300	250	1250
200	290	1450
140	320	1600

$$F_{eq} = F_R \cdot \frac{48.5}{X + 28.5}$$

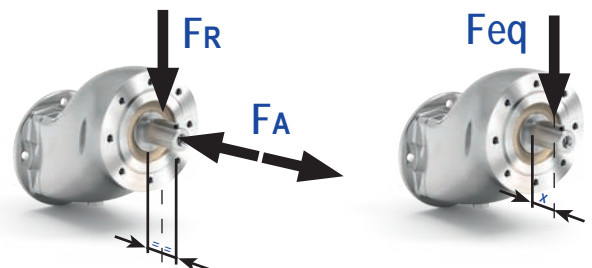

Tab. 1

Tab. 2

P411N-F... **Basic gearbox**
Riduttore base

Gearbox
weight
peso riduttore **5.3 kg**

Input flanges / flange di entrata

	Kit code	k1	g6
71 B14	KI634047	126	105
80 B14	KI634046	128	120
90 B14	KI634041	128	140

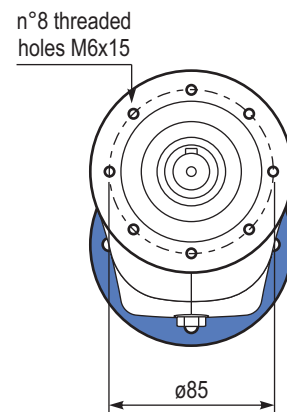
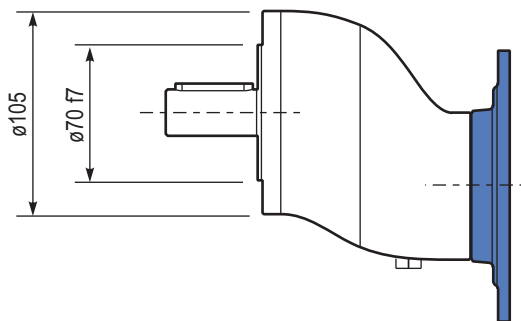
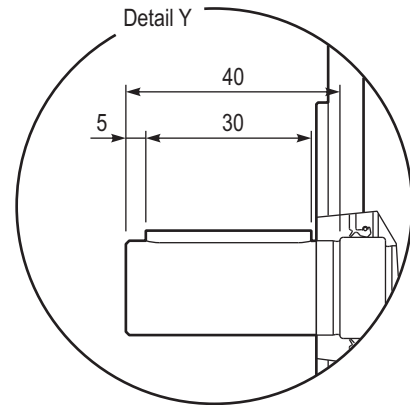
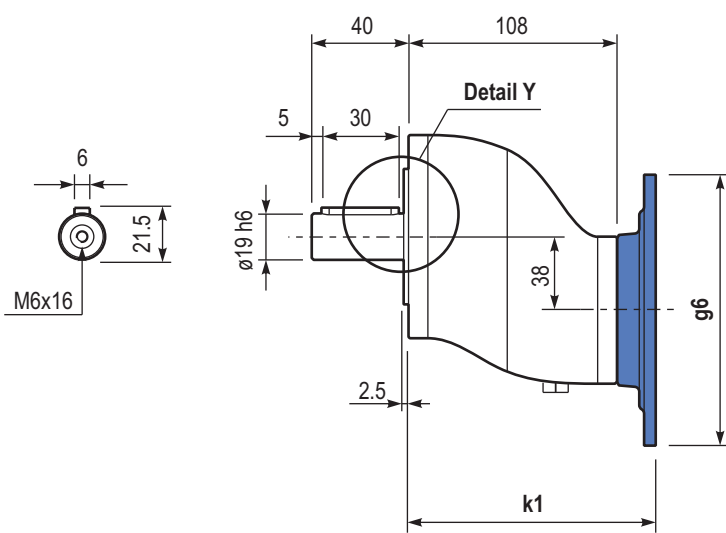



I BVN series Full stainless steel helical bevel gearboxes

Riduttori a coppia conica completamente in acciaio inox

Section **5**
Sezione 5

The best high efficiency solution to resist corrosion. Suitable for all applications.

*La migliore soluzione ad alta efficienza per la resistenza alla corrosione.
Adatto a tutte le applicazioni.*

AISI 316L

IP66

CE







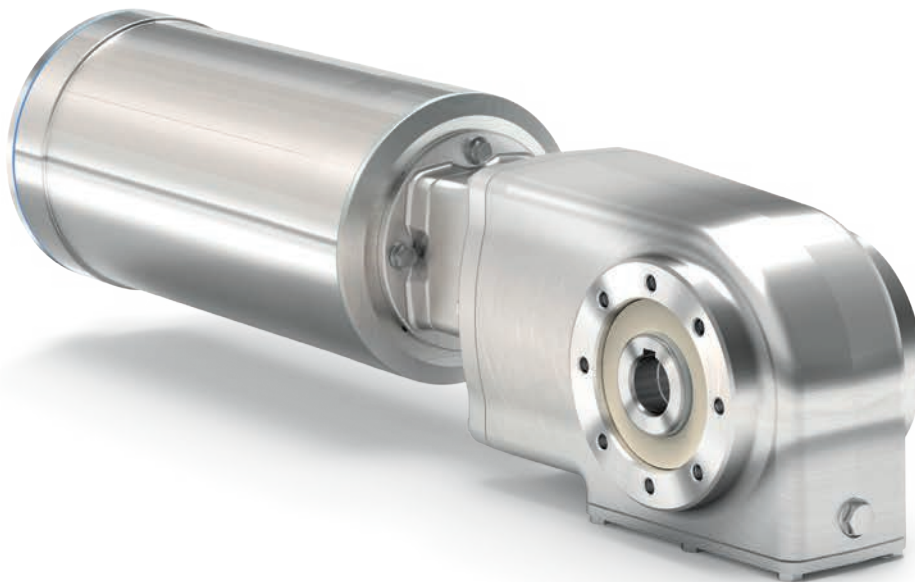





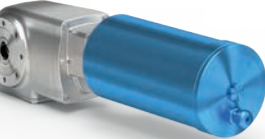



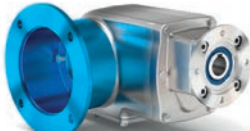





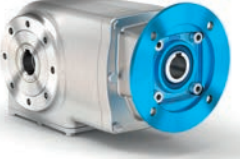

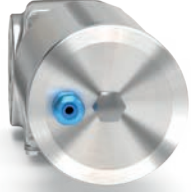
On req.
A rich.

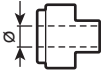
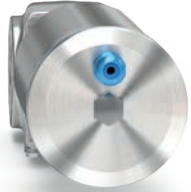
IP69k

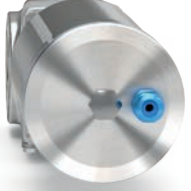

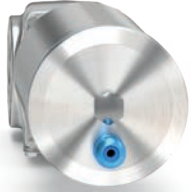
How to order Codifica

M	X42N	I	7.29	-C	BR
Type <i>Tipo</i>	Size <i>Grandezza</i>	Hub <i>Mozzo</i>	Ratio <i>Rapporto</i>	Output shaft <i>Albero uscita</i>	Type <i>Tipo</i>
P 	2 Stages <i>2 Riduzioni</i>	I Stainless steel hollow output shaft <i>Foro albero uscita in acciaio inox</i> 	See technical data table <i>Vedi tabelle dati tecnici</i>	Hollow output shaft <i>Foro albero uscita</i>	FB Universal <i>Forma base</i> 
	X42N X62N			→ Standard X42N - X43N -B → $\varnothing 20$ -C → $\varnothing 25$ X62N - X63N -D → $\varnothing 30$ -E → $\varnothing 35$	
M 	3 Stages <i>3 Riduzioni</i>	S Stainless steel single output shaft <i>Albero uscita singolo in acciaio inox</i> 		→ Standard X42N - X43N -B → $\varnothing 20$ -C → $\varnothing 25$ X62N - X63N -D → $\varnothing 30$ -E → $\varnothing 35$	BR Reaction arm <i>Braccio di reazione</i> 
	X43N X63N X73N			-F → $\varnothing 40$	
B 	4 Stages <i>4 Riduzioni</i>			→ Standard X73N - X74N -F → $\varnothing 40$	-F Output flange <i>Flangia uscita</i> 
	X74N			Single output shaft <i>Albero uscita singolo</i> 	
				→ Standard X42N - X43N -L → $\varnothing 25$ X62N - X63N X73N - X74N -N → $\varnothing 35$	PA 
					PV 

N	-T	B3	ST	For M type specify terminal box position
Output flange <i>Flangia in uscita</i>	Motor size <i>Grandezza motore</i>	Mounting position <i>Posizione di montaggio</i>	Input bore <i>Foro entrata</i>	<i>Per tipo M specificare posizione morsettiera</i>
N Without flange <i>Senza flangia</i> 	Motor flanges <i>Flange motore</i> 	B3 	ST Standard bore <i>Foro standard</i> 	A 
	IEC B14 -P → 63 B14 (ø90) -Q → 71 B14 (ø105) -R → 80 B14 (ø120) -T → 90 B14 (ø140) -U → 100÷112 B14 (ø160)	B6 	Coupling Standard (IEC)  -B → 11mm -C → 14mm -D → 19mm -E → 24mm -F → 28mm	B 
X42N - X43N 2 → ø175 X62N - X63N X73N - X74N	Brushless BB → 50/70-M5 BC → 60/75-M5 BD → 70/90-M6 BE → 80/100-M6 BF → 95/115-M8 BG → 110/145-M8 BH → 130/165-M8 Brushless-Tech catalogue is available in our website <i>Catalogo Brushless-Tech è disponibile nel nostro sito web</i>	B7 	Brushless  -3 → 14mm -4 → 19mm -5 → 22mm -6 → 24mm With reduction bushing where applicable <i>Con bussola di riduzione dove prevista</i>	C 
3 → ø205	Without flange <i>Senza flangia</i> -M Ready for coupling <i>Predisposto per giunto</i>	B8 	Ready for input coupling <i>Predisposto per giunto</i> -0 Type B <i>Tipo B</i> 	D 
	X43N -0 → ø11 (IEC 63) -1 → ø14 (IEC 71)	V5 	V6 	
X42N - X63N - X74N -1 → ø14 (IEC 71) -2 → ø19 (IEC 80) -3 → ø24 (IEC 90) X62N - X73N -2 → ø19 (IEC 80) -3 → ø24 (IEC 90) -4 → ø28 (IEC 100)		V8 		

The dynamic efficiency is **0.96** for all ratios

Input speed (n_1) = 1400 min⁻¹

Output speed n_2 [min ⁻¹]	Ratio i	Motor power P_{1M} [kW]	Output torque M_{2M} [Nm]	Service factor $f.s$	Nominal power P_{1R} [kW]	Nominal torque M_{2R} [Nm]	B5 motor flanges		B14 motor flanges			Output shaft 	Ratio code
							-	-	-Q 71	-R 80	-T 90		
192	7.29	1.5	71	1.1	1.7	80			C	C		2811	01
125	11.20	1.5	110	1.2	1.8	130			C	C		288	02
106	13.18	1.5	129	1.0	1.5	130			C	C		1911	03
92	15.27	1.1	109	1.2	1.3	130			C	C		1711	04
78	17.93	1.1	128	1.0	1.1	130			C	C		1511	05
69	20.25	1.1	145	0.9	0.98	130			C	C		198	06
65	21.40	0.75	105	1.2	0.93	130			C	C		1311	07
60	23.47	0.75	115	1.1	0.85	130			C	C		178	08
51	27.55	0.75	135	1.0	0.72	130			C	C		158	09
47.9	29.21	0.75	143	0.9	0.68	130			C	C		1011	10
42.6	32.88	0.55	119	1.1	0.60	130			C	C		138	11
36.7	38.12	0.55	138	0.9	0.52	130			C	C		911	12
31.2	44.89	0.37	109	1.2	0.44	130			C	C		108	13
27.8	50.34	0.37	122	0.9	0.33	110			C	C		711	14
23.9	58.58	0.37	142	0.9	0.34	130			C	C		98	15
18.1	77.36	0.25	126	1.0	0.26	130			C	C		78	16

Motor flanges available
Flange motore disponibili

 **B) Supplied with reduction bushing**
Fornito con bussola di riduzione

B) Available on request without reduction bushing
Disponibile a richiesta senza bussola di riduzione

 **C) Motor flange holes position**
Posizione fori flangia motore

Lubrication

Lubrificazione

Unit X42N is supplied with synthetic oil to assure long life lubrication. Food grade oil is available on request.

See Table 1 for lubrication and recommended quantity.

See Table 2 for possible radial and axial loads on the gearbox.

Il riduttore tipo X42N viene fornito con olio sintetico e lubrificazione tipo "long life".

Disponibile a richiesta olio alimentare.

Vedi Tabella 1 per oli e quantità consigliati.

Vedi Tabella 2 per i carichi radiali e assiali applicabili al riduttore.

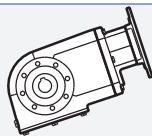
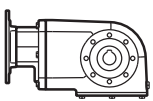
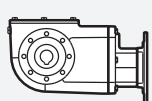
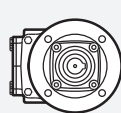
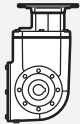
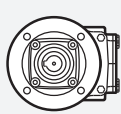
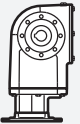
Shell Omala S4 WE 320	Eni Telium VSF 320	V8 On request ASK	
B3 Standard 0.50 L		B8 On request 0.85 L	
B6 On request 0.80 L		V5 On request 1.30 L	
B7 On request 0.75 L		V6 On request 0.90 L	

For more details on lubrication and plugs check our website.

Per maggiori dettagli su lubrificazione e tappi olio vedi il nostro sito web.

Tab. 1

Radial and axial loads

Carichi radiali e assiali

Output shaft

Albero di uscita

n_2 [min ⁻¹]	F_A [N]	F_R [N]
250	500	2500
150	600	3000
100	700	3500
75	800	4000
50	960	4800
25	960	4800
15	960	4800

$$F_{eq} = F_R \cdot \frac{123}{X + 97}$$

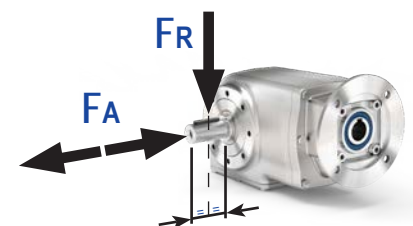
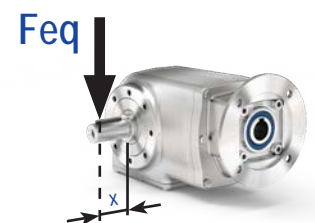

Tab. 2

PX42N...FB Basic gearbox
Riduttore base

M. flanges	Kit code	øF	A
71B14	KI634047	105	198.5
80B14	KI634046	120	200.5
90B14	KI634041	140	200.5

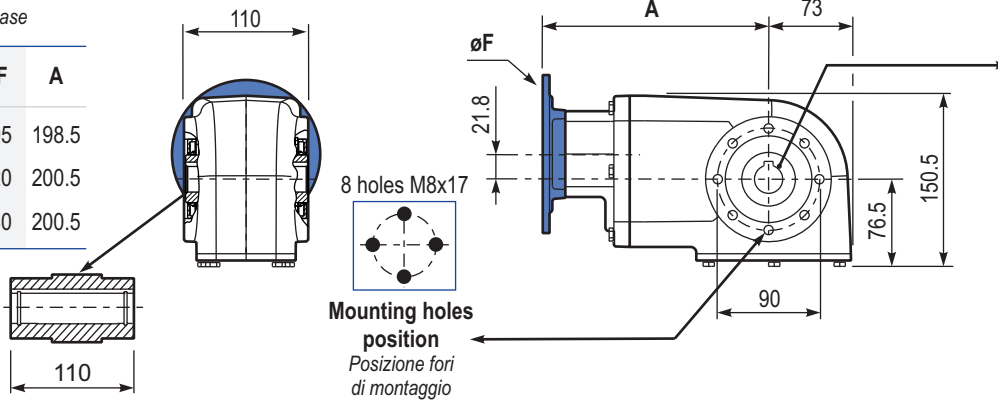

Gearbox weight
peso riduttore **12.8 kg**

Hollow shaft
Foro in uscita

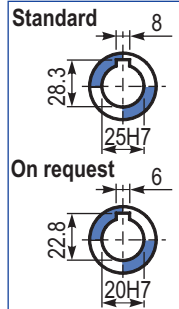

PX42NPA.. Feet
Piedini

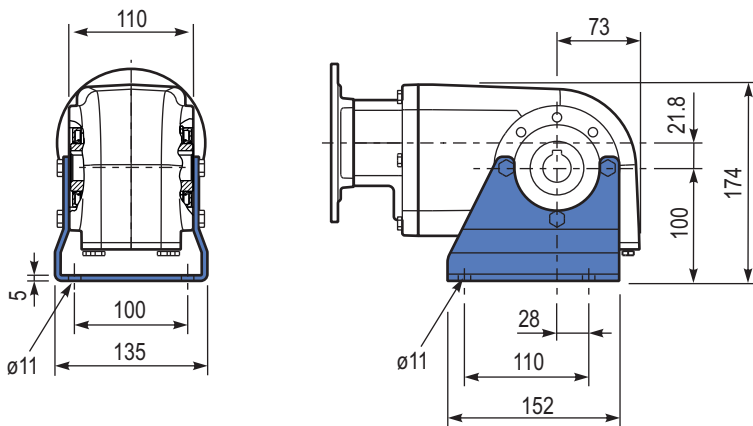

PX42NPV.. Feet
Piedini

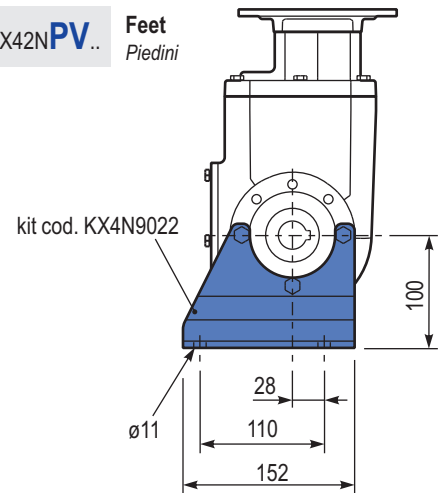

PX42NFL.. Output flange
Flangia uscita

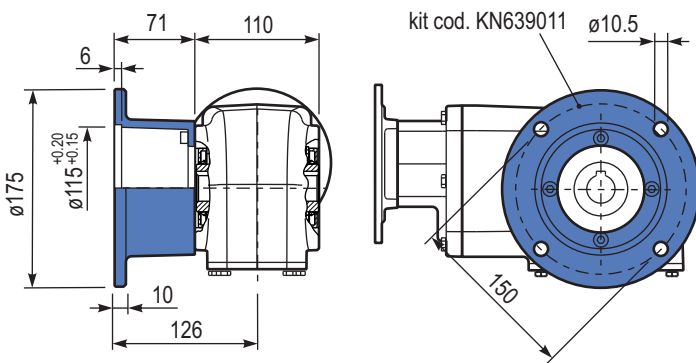

PX42NBR.. Reaction Arm
Braccio di reazione

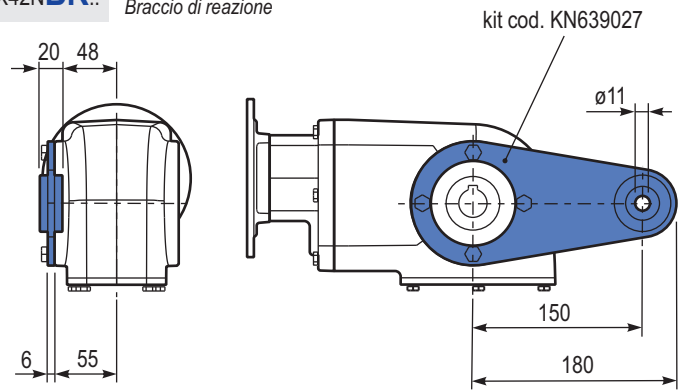

PX42NA.. Single output shaft
Albero semplice in uscita

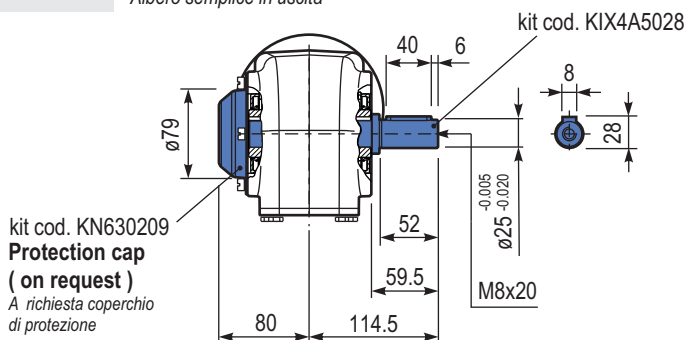

kit cod. KN630209
Protection cap
(on request)
A richiesta coperchio di protezione

Suggested
Suggerito

Stainless steel protection cap
(on request).

Coperchio di protezione in acciaio inox a richiesta.

Kit cod. KN630209



The dynamic efficiency is **0.94** for all ratios

Input speed (n_1) = 1400 min⁻¹

Output speed n_2 [min ⁻¹]	Ratio i	Motor power P_{1M} [kW]	Output torque M_{2M} [Nm]	Service factor $f.s$	Nominal power P_{1R} [kW]	Nominal torque M_{2R} [Nm]	B5 motor flanges		B14 motor flanges		Output shaft 	Ratio code
							-	-	-P 63	-Q 71		
27.8	50.35	0.37	119	1.1	0.40	130			C		171311	01
25.4	55.22	0.37	131	1.0	0.37	130			C		17178	02
23.4	59.92	0.37	142	0.9	0.34	130			C		151311	03
21.3	65.72	0.25	105	1.2	0.31	130			C		15178	04
19.5	71.78	0.25	115	1.1	0.28	130			C		101711	05
17.6	79.44	0.25	127	1.0	0.26	130			C		13178	06
15.2	92.08	0.25	147	0.9	0.22	130			C		15138	07
14.7	95.03	0.25	152	0.9	0.21	130			C		91711	08
11.1	126.55	0.18	155	0.9	0.17	136			C	Standard ø25	71711	09
10.5	133.15	0.12	105	1.3	0.16	136			C		91311	10
9.3	150.18	0.12	119	1.1	0.14	136			C		61711	11
7.9	177.30	0.12	140	1.0	0.12	136			C		71311	12
6.7	210.42	0.12*	166	0.8	0.10	136			C		61311	13
6.1	230.79	0.12*	182	0.7	0.09	136			C		6178	14
5.1	272.47	0.12*	215	0.6	0.08	136			C		7138	15
4.3	323.37	0.12*	256	0.5	0.07	136			C		6138	16

* Power higher than the maximum one which can be supported by the gearbox. Select according to the torque M_{2R}

* Potenza superiore a quella massima sopportabile dal riduttore. Selezionare in base al momento torcente M_{2R}

-  **Motor flanges available**
Flange motore disponibili
-  **B) Supplied with reduction bushing**
Fornito con bussola di riduzione
- B) Available on request without reduction bushing**
Disponibile a richiesta senza bussola di riduzione
-  **C) Motor flange holes position**
Posizione fori flangia motore

Lubrication

Lubrificazione

Unit X43N is supplied with synthetic oil to assure long life lubrication. Food grade oil is available on request.

See Table 1 for lubrication and recommended quantity.

See Table 2 for possible radial and axial loads on the gearbox.

Il riduttore tipo X43N viene fornito con olio sintetico e lubrificazione tipo "long life". Disponibile a richiesta olio alimentare.

Vedi Tabella 1 per oli e quantità consigliati.

Vedi Tabella 2 per i carichi radiali e assiali applicabili al riduttore.

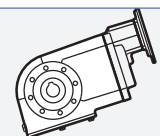
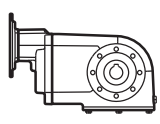
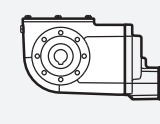
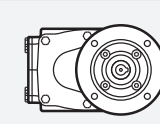
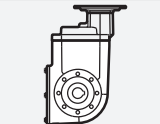
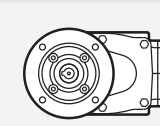
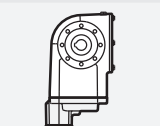
Shell Omala S4 WE 320	Eni Telium VSF 320	V8 On request ASK	
B3 Standard 0.90 L		B8 On request 0.85 L	
B6 On request 0.80 L		V5 On request 1.40 L	
B7 On request 0.75 L		V6 On request 0.90 L	

For more details on lubrication and plugs check our website.
Per maggiori dettagli su lubrificazione e tappi olio vedi il nostro sito web.

Tab. 1

Radial and axial loads

Carichi radiali e assiali

Output shaft

Albero di uscita

n_2 [min ⁻¹]	F_A [N]	F_R [N]
250	500	2500
150	600	3000
100	700	3500
75	800	4000
50	960	4800
25	960	4800
15	960	4800

$$F_{eq} = F_R \cdot \frac{123}{X + 97}$$

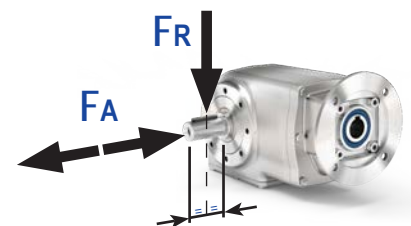
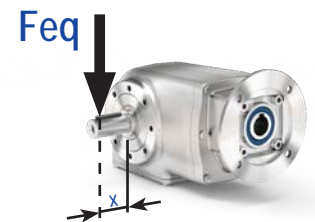

Tab. 2

PX43NI...FB Basic gearbox
Riduttore base

M. flanges	Kit code	øF	A
63B14	KI504047	90	206
71B14	KI504045	105	203.5

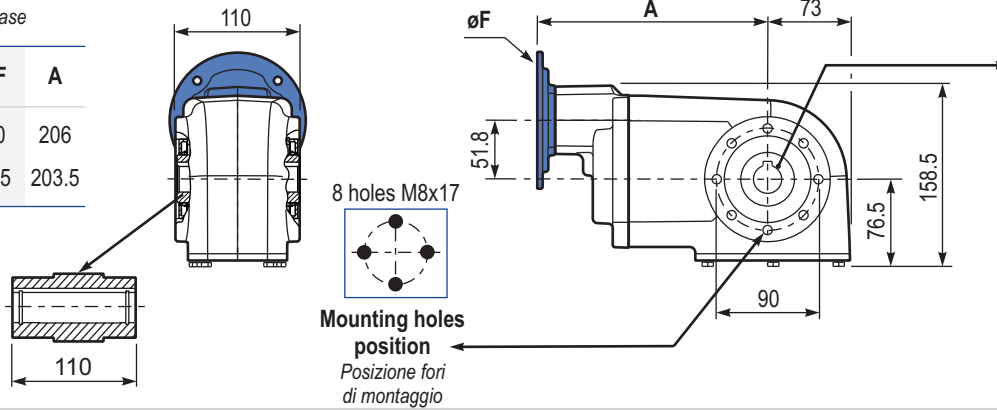

Gearbox weight
peso riduttore **13.0 kg**

Hollow shaft
Foro in uscita

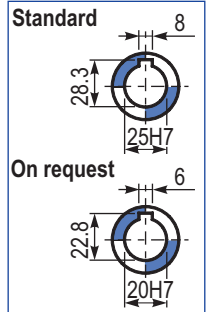

PX43NPA.. Feet
Piedini

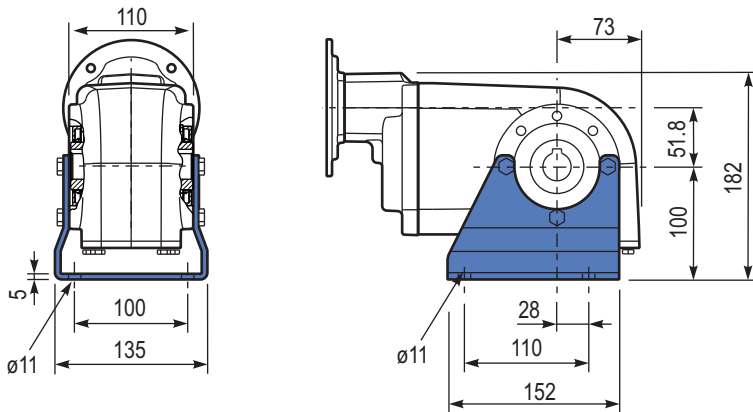

PX43NPV.. Feet
Piedini

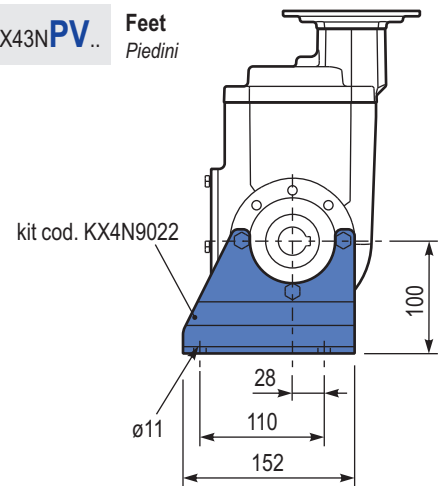

PX43N-FL.. Output flange
Flangia uscita

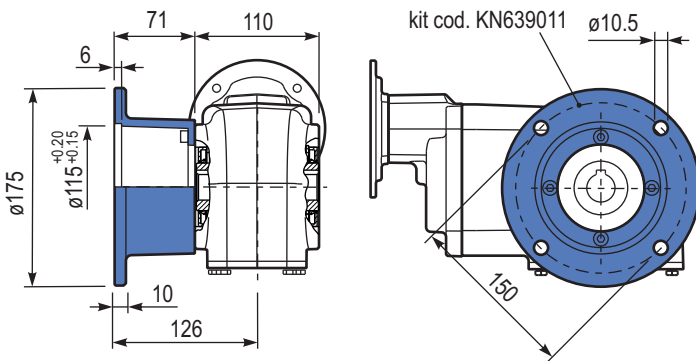

PX43NBR.. Reaction Arm
Braccio di reazione

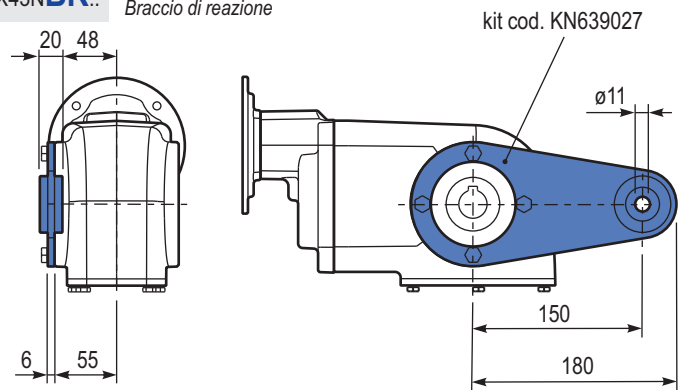

PX43N..A.. Single output shaft
Albero semplice in uscita

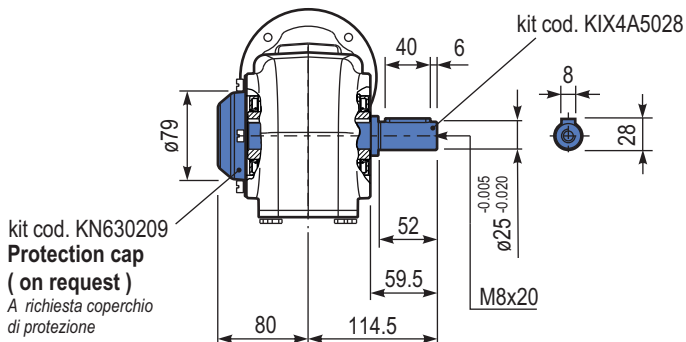

kit cod. KN630209
Protection cap
(on request)
A richiesta coperchio di protezione

Suggested
Suggerito

Stainless steel protection cap
(on request).

Coperchio di protezione in acciaio inox a richiesta.

Kit cod. KN630209



The dynamic efficiency is **0.96** for all ratios

Input speed (n_1) = 1400 min⁻¹

Output speed n_2 [min ⁻¹]	Ratio i	Motor power P_{1M} [kW]	Output torque M_{2M} [Nm]	Service factor f_s	Nominal power P_{1R} [kW]	Nominal torque M_{2R} [Nm]	B5 motor flanges			B14 motor flanges			Output shaft 	Ratio code	
							-	-	-	-R	-T	-U			
232	6.03	4	155	1.6	6.1	240	-	-	-	-R	-T	-U	Standard ø35	01	
151	9.26	4	238	1.1	4.5	270	-	-	-	80	90	100-112		3011	02
123	11.36	4	291	1.2	4.7	350	-	-	-	-	-	-		308	03
91	15.36	4	394	1.0	3.8	385	-	-	-	-	-	-		2011	04
80	17.46	4	448	0.9	3.5	400	-	-	-	-	-	-		1611	05
70	19.97	3	386	1.1	3.1	410	-	-	-	-	-	-		208	06
59	23.60	3	456	0.9	2.7	410	-	-	-	-	-	-		1311	07
57	24.45	3	472	0.9	2.6	410	-	-	-	-	-	-		168	08
45.6	30.69	2.2	436	0.9	2.0	410	-	-	-	-	-	-		1111	09
39.6	35.35	1.5	346	1.2	1.8	410	-	-	-	-	-	-		138	10
37.3	37.57	1.5	368	1.1	1.7	410	-	-	-	-	-	-		811	11
28.8	48.68	1.1	348	1.0	1.1	365	-	-	-	-	-	-		118	12
25.8	54.33	1.1	389	1.1	1.2	410	-	-	-	-	-	-		611	13
18.7	74.81	0.75	367	1.0	0.73	360	-	-	-	-	-	-		88	14
							-	-	-	-	-	-	68		

Motor flanges available
Flange motore disponibili

 **B) Supplied with reduction bushing**
Fornito con bussola di riduzione

B) Available on request without reduction bushing
Disponibile a richiesta senza bussola di riduzione

 **C) Motor flange holes position**
Posizione fori flangia motore

Lubrication

Lubrificazione

Unit X62N is supplied with synthetic oil to assure long life lubrication. Food grade oil is available on request.

See Table 1 for lubrication and recommended quantity.

See Table 2 for possible radial and axial loads on the gearbox.

Il riduttore tipo X62N viene fornito con olio sintetico e lubrificazione tipo "long life".

Disponibile a richiesta olio alimentare.

Vedi Tabella 1 per oli e quantità consigliati.

Vedi Tabella 2 per i carichi radiali e assiali applicabili al riduttore.

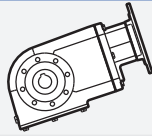
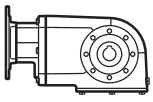
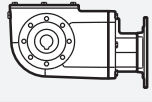
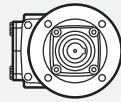
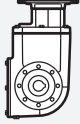
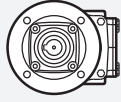
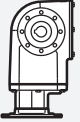
Shell Omala S4 WE 320	Eni Telium VSF 320	V8 On request ASK	
B3 Standard 1.05 L		B8 On request 1.90 L	
B6 On request 1.85 L		V5 On request 3.20 L	
B7 On request 1.70 L		V6 On request 2.25 L	

For more details on lubrication and plugs check our website.

Per maggiori dettagli su lubrificazione e tappi olio vedi il nostro sito web.

Tab. 1

Radial and axial loads

Carichi radiali e assiali

Output shaft

Albero di uscita

n_2 [min ⁻¹]	F_A [N]	F_R [N]
250	600	3000
150	700	3500
100	780	3900
75	890	4450
50	1140	5700
25	1330	6650
15	1660	8300

$$F_{eq} = F_R \cdot \frac{168}{X + 138}$$

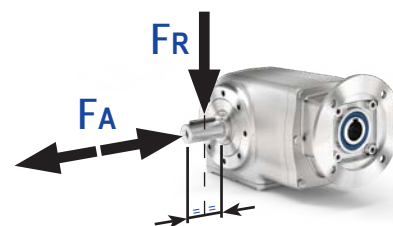
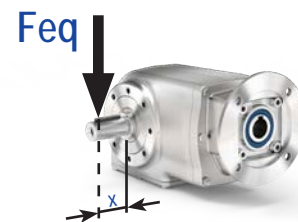

Tab. 2

PX62NI...FB Basic gearbox
Riduttore base

M. flanges	Kit code	øF	A
80B14	KI854046	120	255
90B14	KI854045	140	255
100-112B14	KI854041	160	264

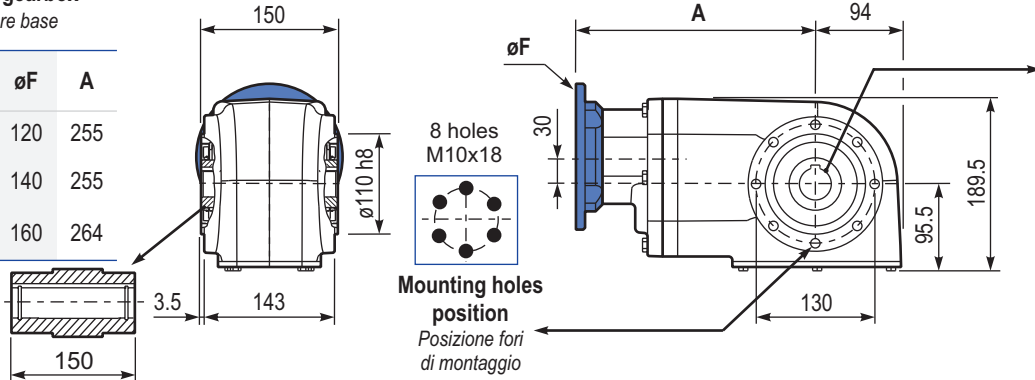

Gearbox weight peso riduttore **23.2 kg**

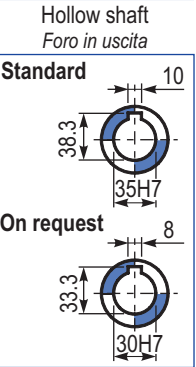

PX62NPA.. Feet
Piedini

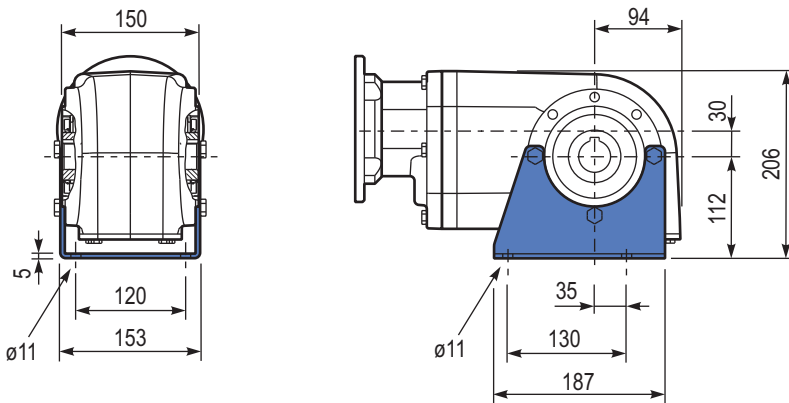

PX62NPV.. Feet
Piedini

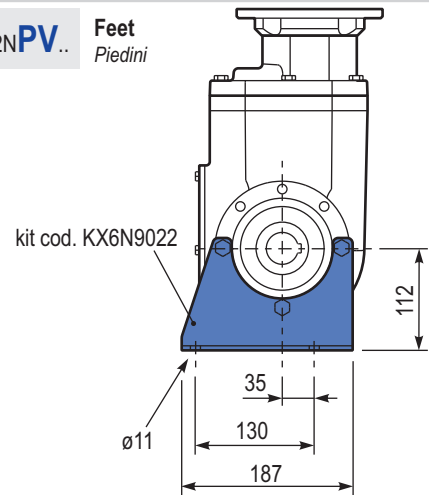

PX62NFL.. Output flange
Flangia uscita

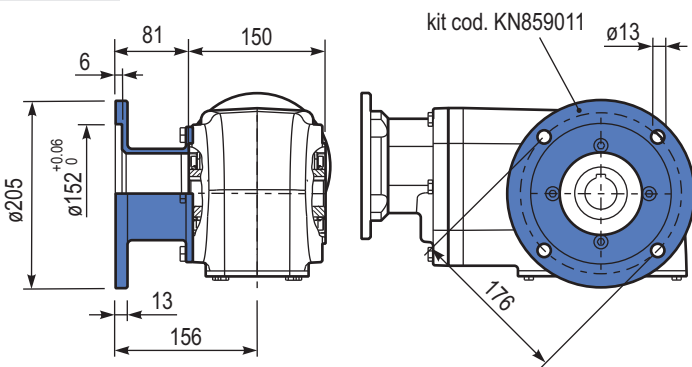

PX62NBR.. Reaction Arm
Braccio di reazione

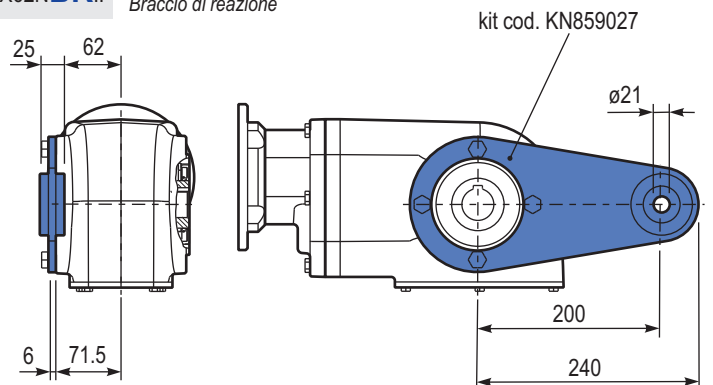

PX62NA.. Single output shaft
Albero semplice in uscita

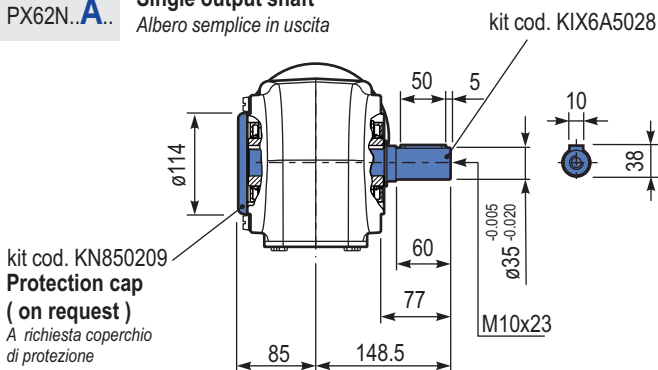

kit cod. KN850209
Protection cap
(on request)
A richiesta coperchio di protezione

Suggested
Suggerito

Stainless steel protection cap (on request).

Coperchio di protezione in acciaio inox a richiesta.

Kit cod. KN850209



The dynamic efficiency is **0.94** for all ratios

Input speed (n_1) = 1400 min⁻¹

Output speed n_2 [min ⁻¹]	Ratio i	Motor power P_{1M} [kW]	Output torque M_{2M} [Nm]	Service factor $f.s$	Nominal power P_{1R} [kW]	Nominal torque M_{2R} [Nm]	B5 motor flanges			B14 motor flanges			Output shaft 	Ratio code	
							-	-	-	-Q	-R	-T			
24.7	56.76	1.1	398	1.0	1.1	410	-	-	-	-Q	-R	-T	Standard ø35	01	
21.3	65.79	0.75	316	1.3	0.97	410	-	-	-	71	80	90		171311	02
18.1	77.23	0.75	371	1.1	0.83	410	-	-	-	C	C			151311	03
16.0	87.23	0.75	420	1.0	0.73	410	-	-	-	C	C			19138	04
15.2	92.18	0.75	443	0.9	0.69	410	-	-	-	C	C			131311	05
13.9	100.47	0.55	357	1.2	0.64	410	-	-	-	C	C			19811	06
12.0	116.45	0.55	413	1.0	0.55	410	-	-	-	C	C			17811	07
11.1	125.82	0.55	446	0.9	0.51	410	-	-	-	C	C			101311	08
9.9	141.66	0.37	336	1.2	0.45	410	-	-	-	C	C			13138	09
8.6	163.16	0.37	387	1.1	0.39	410	-	-	-	C	C			13811	10
7.8	178.96	0.37	424	1.0	0.36	410	-	-	-	C	C			1788	11
7.2	193.36	0.37	459	0.9	0.33	410	-	-	-	C	C			10138	12
6.5	216.84	0.25	347	1.2	0.29	410	-	-	-	C	C			71311	13
5.5	252.36	0.25	404	1.0	0.25	410	-	-	-	C	C			9138	14
4.8	290.67	0.25	465	0.9	0.22	410	-	-	-	C	C			9811	15
4.2	333.23	0.25	533	0.8	0.19	410	-	-	-	C	C			7138	16
3.6	383.82	0.25*	614	0.7	0.17	410	-	-	-	C	C			7811	17
3.1	446.70	0.25*	715	0.6	0.14	410	-	-	-	C	C			988	18
2.4	589.85	0.25*	944	0.4	0.11	410	-	-	-	C	C			788	19

* Power higher than the maximum one which can be supported by the gearbox. Select according to the torque M_{2R}
 Potenza superiore a quella massima sopportabile dal riduttore. Selezionare in base al momento torcente M_{2R}

Motor flanges available
Flange motore disponibili



B) Supplied with reduction bushing
Fornito con bussola di riduzione



B) Available on request without reduction bushing
Disponibile a richiesta senza bussola di riduzione



C) Motor flange holes position
Posizione fori flangia motore

Lubrication

Lubrificazione

Unit X63N is supplied with synthetic oil to assure long life lubrication. Food grade oil is available on request.

See Table 1 for lubrication and recommended quantity.

See Table 2 for possible radial and axial loads on the gearbox.

Il riduttore tipo X63N viene fornito con olio sintetico e lubrificazione tipo "long life".

Disponibile a richiesta olio alimentare.

Vedi Tabella 1 per oli e quantità consigliati.

Vedi Tabella 2 per i carichi radiali e assiali applicabili al riduttore.

Shell Omala S4 WE 320	Eni Telium VSF 320	V8 On request ASK	
B3 Standard 2.05 L		B8 On request 1.90 L	
B6 On request 1.85 L		V5 On request 3.40 L	
B7 On request 1.70 L		V6 On request 2.25 L	

For more details on lubrication and plugs check our website.
Per maggiori dettagli su lubrificazione e tappi olio vedi il nostro sito web.

Radial and axial loads

Carichi radiali e assiali

Output shaft

Albero di uscita

n_2 [min ⁻¹]	F_A [N]	F_R [N]
250	600	3000
150	700	3500
100	780	3900
75	890	4450
50	1140	5700
25	1330	6650
15	1660	8300

$$F_{eq} = F_R \cdot \frac{168}{X + 138}$$

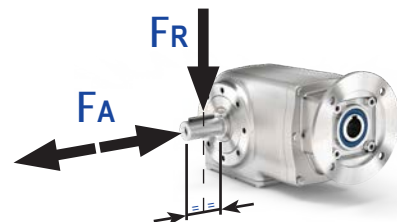
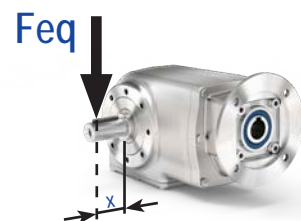

410 Nm

X63N

PX63NI...FB

Basic gearbox
Riduttore base

M. flanges	Kit code	øF	A
71B14	KI634047	105	263
80B14	KI634046	120	265
90B14	KI634041	140	265

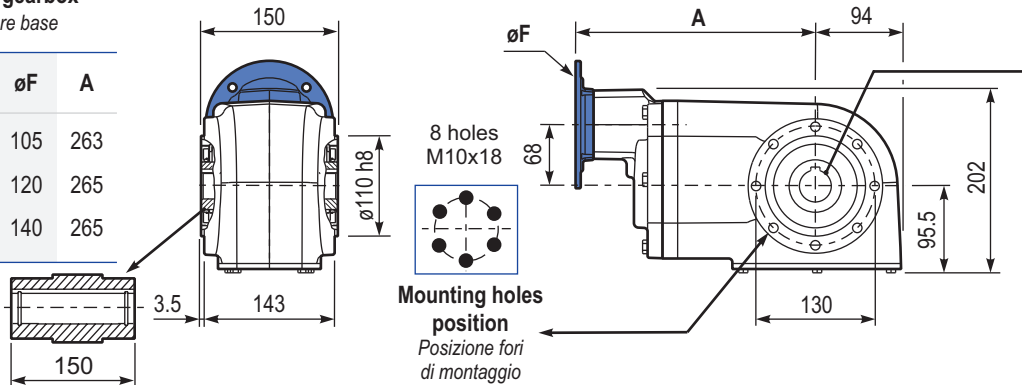

Gearbox weight
peso riduttore **23.2 kg**

Hollow shaft
Foro in uscita

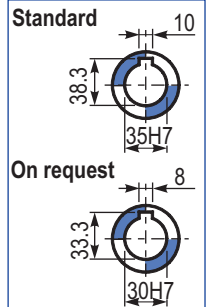

PX63NPA..

Feet
Piedini

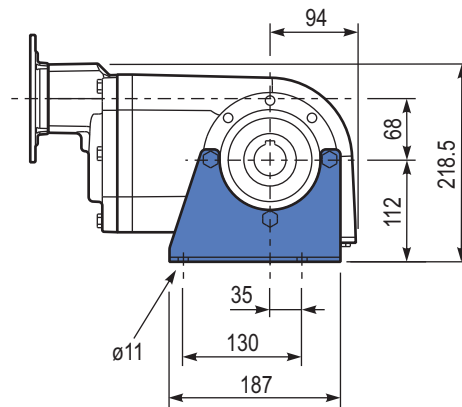
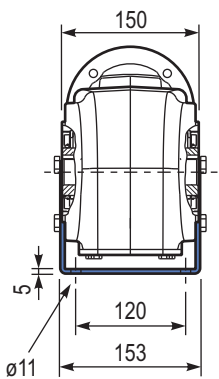

PX63NPV..

Feet
Piedini

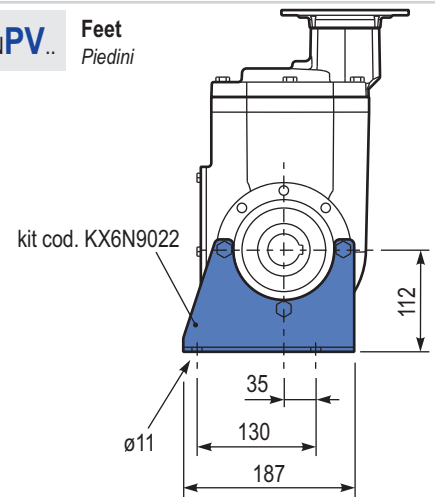

PX63NFL..

Output flange
Flangia uscita

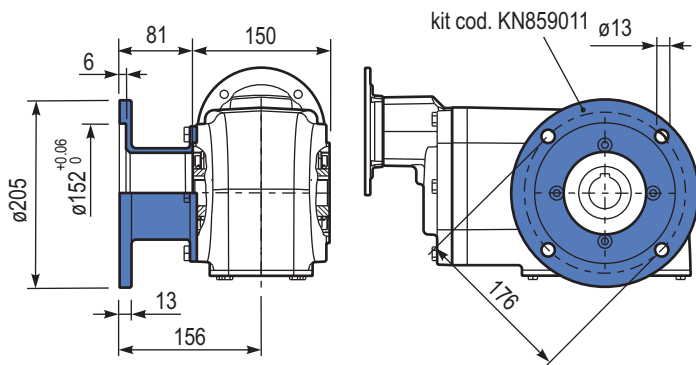

PX63NBR..

Reaction Arm
Braccio di reazione

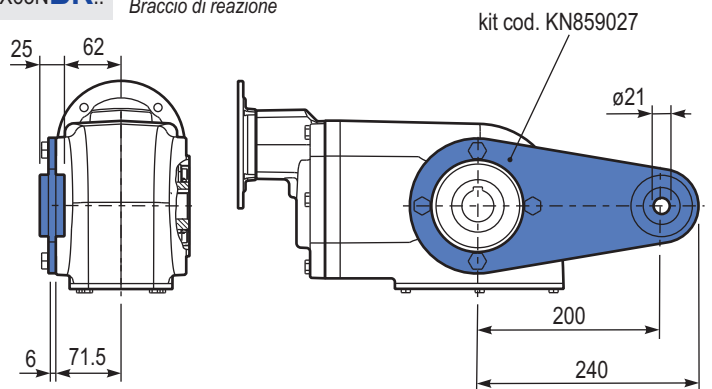

PX63NA..

Single output shaft
Albero semplice in uscita

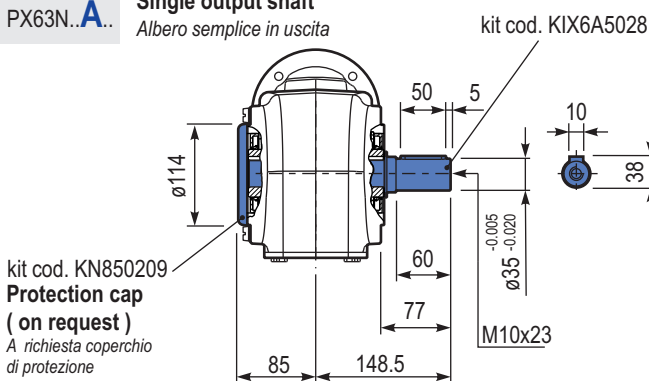

kit cod. KN850209
Protection cap
(on request)
A richiesta coperchio di protezione

Suggested
Suggerito

Stainless steel protection cap
(on request).



Coperchio di protezione in acciaio inox a richiesta.

Kit cod. KN850209



The dynamic efficiency is **0.94** for all ratios

Input speed (n_1) = 1400 min⁻¹

Output speed n_2 [min ⁻¹]	Ratio i	Motor power P_{1M} [kW]	Output torque M_{2M} [Nm]	Service factor $f.s$	Nominal power P_{1R} [kW]	Nominal torque M_{2R} [Nm]	B5 motor flanges		B14 motor flanges			Output shaft 	Ratio code 
							-	-	-R	-T	-U		
							-	-	-R	-T	-U		
							-	-	80	90	100-112		
176	7.94	4	200	1.9	7.5	380						302418	01
153	9.13	4	229	1.7	6.7	390						302416	02
131	10.66	4	268	1.5	6.0	410						302414	03
94	14.97	4	376	1.5	6.0	580						202418	04
81	17.21	4	432	1.4	5.4	600						202416	05
69	20.24	4	509	1.3	5.2	675						162418	06
60	23.27	4	585	1.2	4.5	675						162416	07
53	26.31	4	661	1.0	4.0	675						132418	08
46.3	30.25	4	760	0.9	3.5	675						132416	09
39.6	35.32	3	668	1.0	3.0	675						132414	10
37.8	37.03	3	701	1.0	2.8	675						112416	11
32.4	43.23	2.2	602	1.1	2.4	675						112414	12
30.1	46.58	2.2	649	1.0	2.3	675						82418	13
26.1	53.55	2.2	746	0.9	2.0	675						82416	14
22.4	62.52	1.5	600	1.1	1.7	675						82414	15
19.0	73.75	1.1	517	1.1	1.2	580						62416	16
16.3	86.09	1.1	604	1.1	1.2	675						62414	17

Motor flanges available
Flange motore disponibili

 B) Supplied with reduction bushing
Fornito con bussola di riduzione

B) Available on request without reduction bushing
Disponibile a richiesta senza bussola di riduzione

 C) Motor flange holes position
Posizione fori flangia motore

Lubrication

Lubrificazione

Unit X73N is supplied with synthetic oil to assure long life lubrication. Food grade oil is available on request.

See Table 1 for lubrication and recommended quantity.

See Table 2 for possible radial and axial loads on the gearbox.

Il riduttore tipo X73N viene fornito con olio sintetico e lubrificazione tipo "long life". Disponibile a richiesta olio alimentare.

Vedi Tabella 1 per oli e quantità consigliati.

Vedi Tabella 2 per i carichi radiali e assiali applicabili al riduttore.

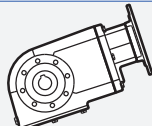
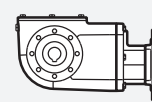
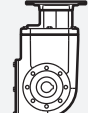
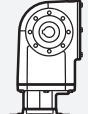
Shell	Eni	V8	
Omala S4 WE 320	Telium VSF 320	On request ASK	
B3		B8	
Standard 1.60 L		On request 2.90 L	
B6		V5	
On request 2.80 L		On request 4.60 L	
B7		V6	
On request 2.10 L		On request 3.30 L	

For more details on lubrication and plugs check our website.
Per maggiori dettagli su lubrificazione e tappi olio vedi il nostro sito web.

Tab. 1

Radial and axial loads

Carichi radiali e assiali

Output shaft

Albero di uscita

n_2 [min ⁻¹]	F_A [N]	F_R [N]
300	1360	6800
250	1400	7000
200	1440	7200
140	1480	7400
120	1520	7600
85	1560	7800
70	1720	8600
40	1840	9200
15	1920	9600

$$F_{eq} = F_R \cdot \frac{178.5}{X + 145.5}$$

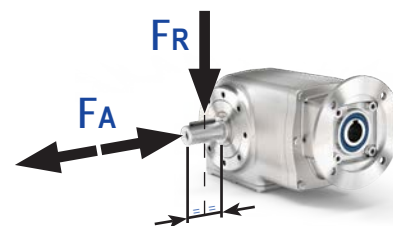
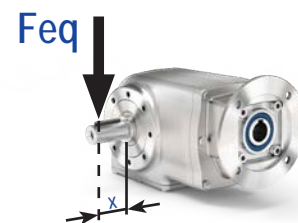

Tab. 2

PX73NI...FB Basic gearbox
Riduttore base

M. flanges	Kit code	øF	A
80B14	KI854046	120	302
90B14	KI854045	140	302
100-112B14	KI854041	160	311

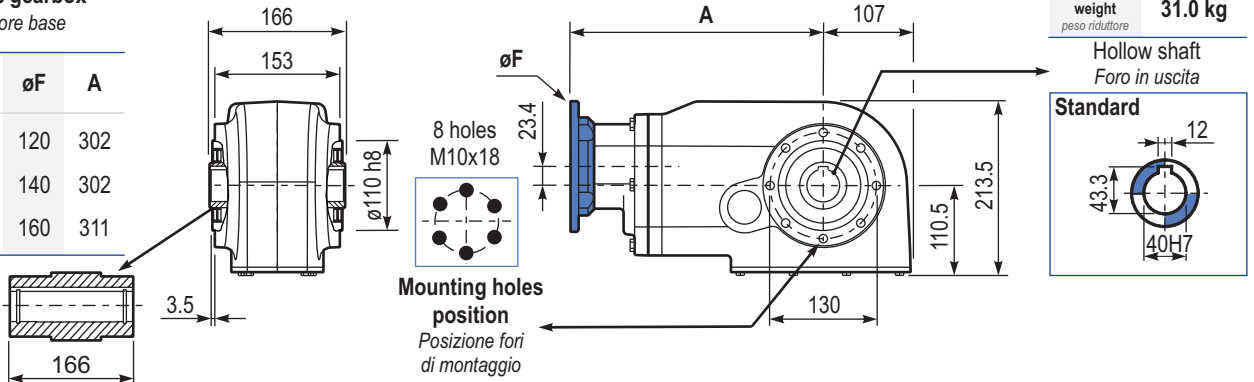

Gearbox weight
peso riduttore **31.0 kg**

Hollow shaft
Foro in uscita

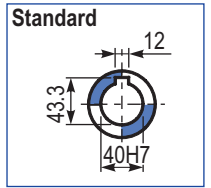

PX73NPA.. Feet
Piedini

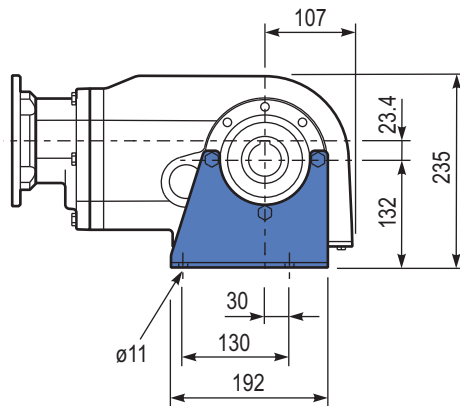
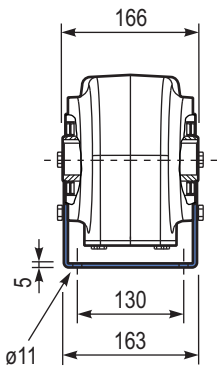

PX73NPV.. Feet
Piedini

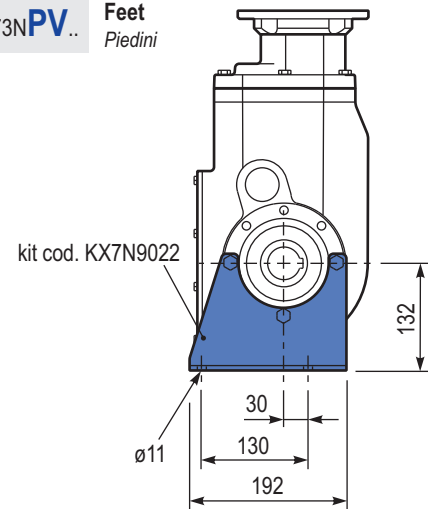

PX73NFL.. Output flange
Flangia uscita

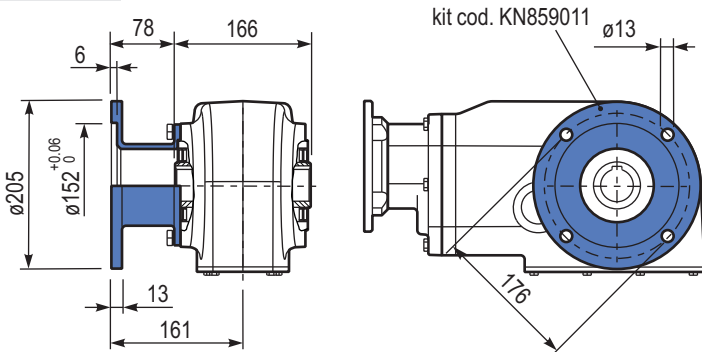

PX73NBR.. Reaction Arm
Braccio di reazione

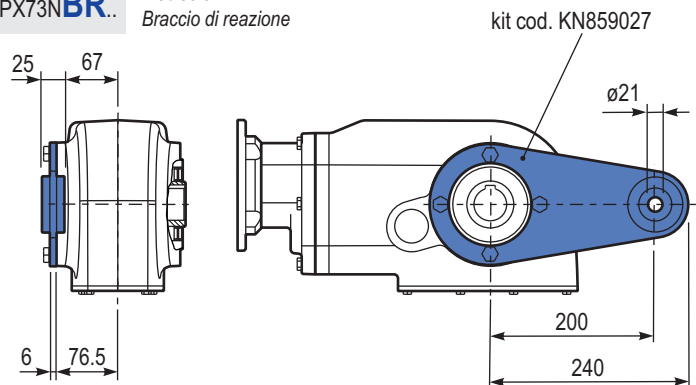

PX73NA.. Single output shaft
Albero semplice in uscita

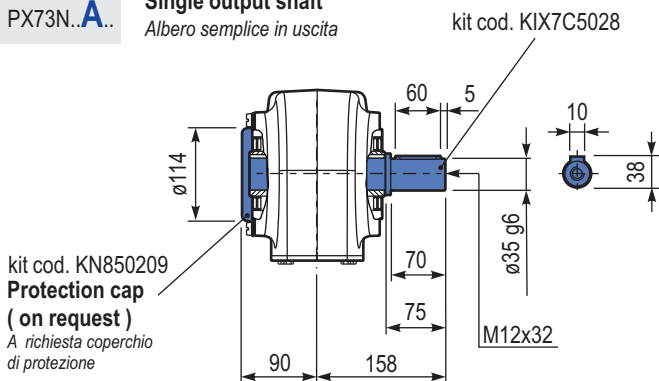

kit cod. KN850209
Protection cap
(on request)
A richiesta coperchio di protezione

Suggested
Suggerito

Stainless steel protection cap
(on request).

Coperchio di protezione in acciaio inox a richiesta.

Kit cod. KN850209



The dynamic efficiency is **0.92** for all ratios

Input speed (n_1) = 1400 min⁻¹

Output speed n_2 [min ⁻¹]	Ratio i	Motor power P_{1M} [kW]	Output torque M_{2M} [Nm]	Service factor $f.s$	Nominal power P_{1R} [kW]	Nominal torque M_{2R} [Nm]	B5 motor flanges			B14 motor flanges			Output shaft 	Ratio code
							-	-	-	-Q	-R	-T		
18.7	74.79	1.5	704	1.0	1.4	675	-	-	-	C	C		19132418	01
16.3	85.99	1.1	591	1.1	1.3	675	-	-	-	C	C		19132416	02
14.0	99.66	1.1	685	1.0	1.1	675	-	-	-	C	C		17132416	03
12.0	116.35	0.75	548	1.2	0.92	675	-	-	-	C	C		17132414	04
11.5	121.45	0.75	572	1.2	0.89	675	-	-	-	C	C		13132418	05
10.0	139.64	0.75	658	1.0	0.77	675	-	-	-	C	C		13132416	06
9.2	152.21	0.75	717	0.9	0.71	675	-	-	-	C	C		19082416	07
8.6	163.02	0.55	567	1.2	0.66	675	-	-	-	C	C		13132414	08
7.9	177.69	0.55	618	1.1	0.61	675	-	-	-	C	C		19082414	09
6.8	205.95	0.55	716	0.9	0.52	675	-	-	-	C	C	Standard ø35	17082414	10
6.3	222.52	0.55	774	0.9	0.48	675	-	-	-	C	C		10132414	11
5.6	248.76	0.37	578	1.2	0.43	675	-	-	-	C	C		9132416	12
4.8	290.41	0.37	675	1.0	0.37	675	-	-	-	C	C		9132414	13
4.1	337.39	0.37	784	0.9	0.32	675	-	-	-	C	C		10082416	14
3.6	393.88	0.25	618	1.1	0.27	675	-	-	-	C	C		10082414	15
3.2	440.33	0.25	690	1.0	0.24	675	-	-	-	C	C		9082416	16
2.7	514.06	0.25	806	0.8	0.21	675	-	-	-	C	C		9082414	17
2.4	581.44	0.25*	912	0.7	0.18	675	-	-	-	C	C		7082416	18
2.1	678.79	0.25*	1064	0.6	0.16	675	-	-	-	C	C		7082414	19

* Power higher than the maximum one which can be supported by the gearbox. Select according to the torque M_{2R}
Potenza superiore a quella massima sopportabile dal riduttore. Selezionare in base al momento torcente M_{2R}

Motor flanges available
Flange motore disponibili

 B) Supplied with reduction bushing
Fornito con bussola di riduzione

B) Available on request without reduction bushing
Disponibile a richiesta senza bussola di riduzione

 C) Motor flange holes position
Posizione fori flangia motore

Lubrication

Lubrificazione

Unit X74N is supplied with synthetic oil to assure long life lubrication.
Food grade oil is available on request.

See Table 1 for lubrication and recommended quantity.

See Table 2 for possible radial and axial loads on the gearbox.

Il riduttore tipo X74N viene fornito con olio sintetico e lubrificazione tipo "long life".

Disponibile a richiesta olio alimentare.

Vedi Tabella 1 per oli e quantità consigliati.

Vedi Tabella 2 per i carichi radiali e assiali applicabili al riduttore.

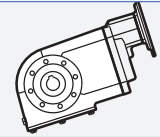
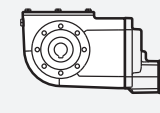
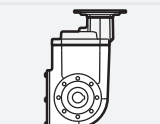
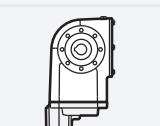
Shell	Eni	V8	
Omala S4 WE 320	Telium VSF 320	On request ASK	
B3		B8	
Standard 2.60 L		On request 2.90 L	
B6		V5	
On request 2.80 L		On request 4.80 L	
B7		V6	
On request 2.10 L		On request 3.30 L	

For more details on lubrication and plugs check our website.
Per maggiori dettagli su lubrificazione e tappi olio vedi il nostro sito web.

Radial and axial loads

Carichi radiali e assiali

Output shaft

Albero di uscita

n_2 [min ⁻¹]	F_A [N]	F_R [N]
300	1360	6800
250	1400	7000
200	1440	7200
140	1480	7400
120	1520	7600
85	1560	7800
70	1720	8600
40	1840	9200
15	1920	9600

$$F_{eq} = F_R \cdot \frac{178.5}{X + 143.5}$$

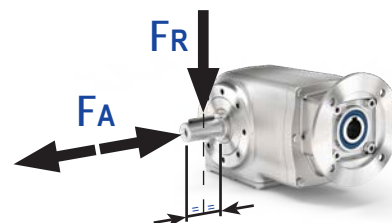
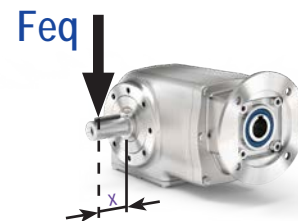

PX74NI...FB Basic gearbox
Riduttore base

M. flanges	Kit code	øF	A
71B14	KI634047	105	310
80B14	KI634046	120	312
90B14	KI634041	140	312

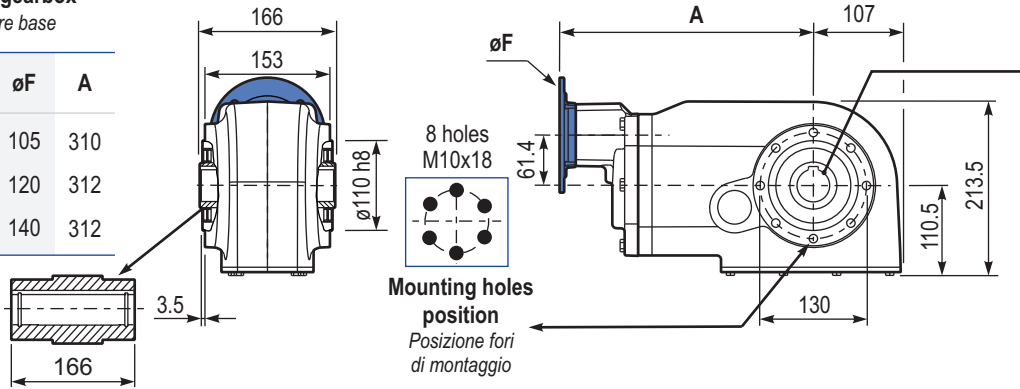

Gearbox weight peso riduttore **31.0 kg**

Hollow shaft Foro in uscita

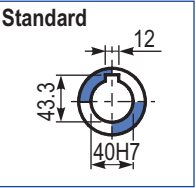

PX74NPA.. Feet
Piedini

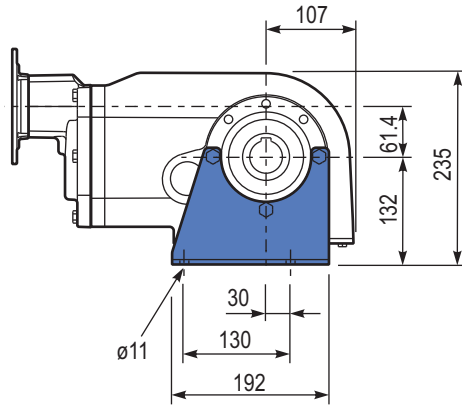
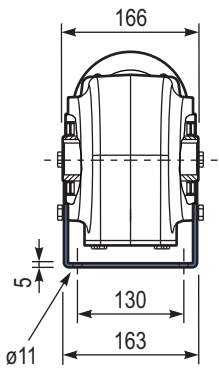

PX74NPV.. Feet
Piedini

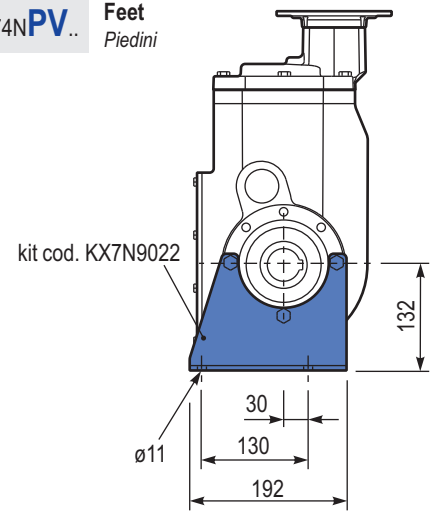

PX74NFL.. Output flange
Flangia uscita

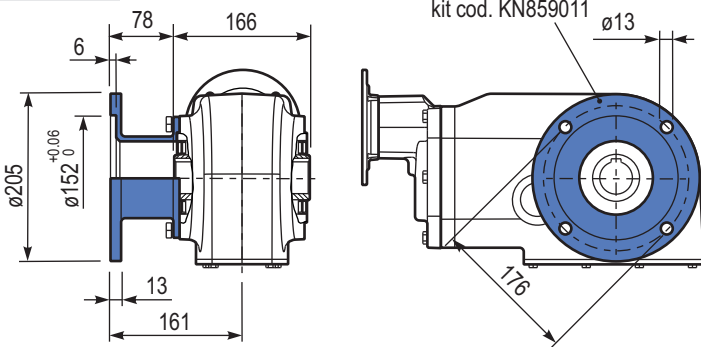

PX74NBR.. Reaction Arm
Braccio di reazione

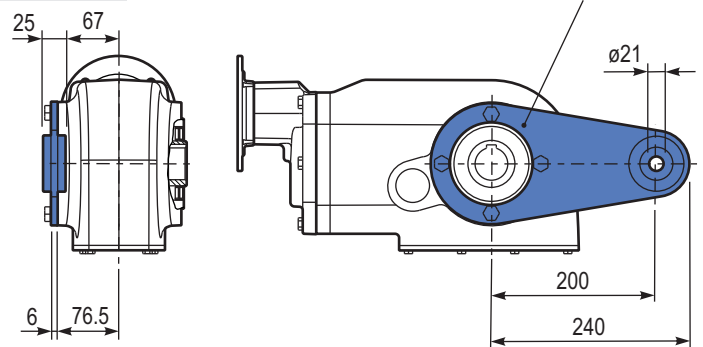

PX74NA.. Single output shaft
Albero semplice in uscita

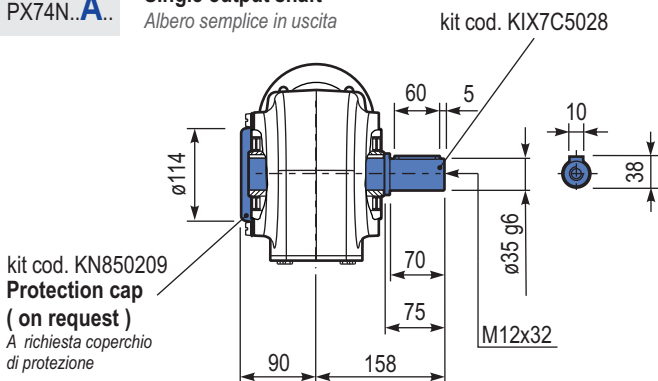

Suggested
Suggerito

Stainless steel protection cap (on request).

Coperchio di protezione in acciaio inox a richiesta.

Kit cod. KN850209





Uniblock design. Suitable for all applications.

*Design compatto.
Adatto a tutte le applicazioni.*

AISI 304

IP66

CE







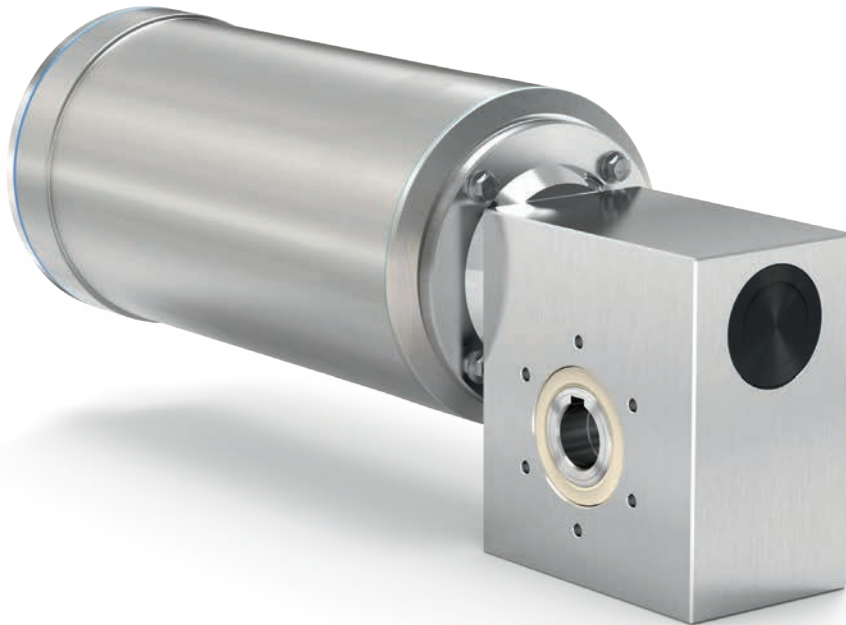



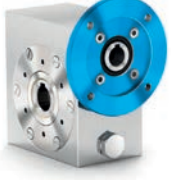
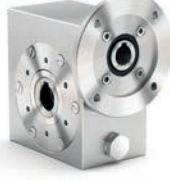
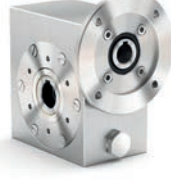

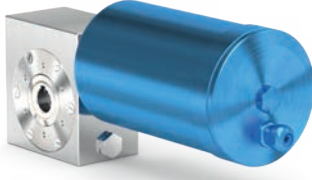



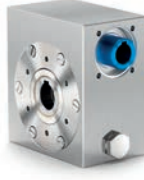
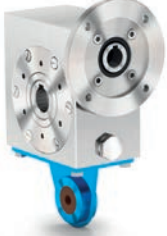
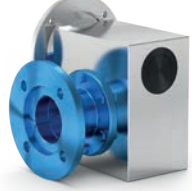

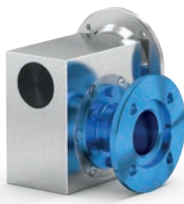



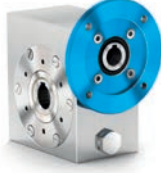

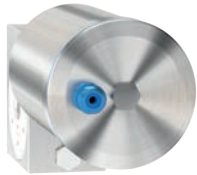

On req.
A rich.

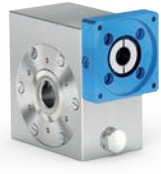
IP69k

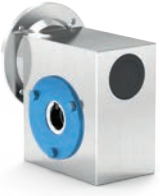
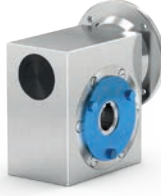

How to order Codifica

P	I45	UNI	N	10	0	MB
Type <i>Tipo</i>	Size <i>Grandezza</i>	Mounting <i>Montaggio</i>	Position <i>Posizione</i>	Ratio <i>Rapporto</i>	Hub Output shaft <i>Mozzo corona Albero uscita</i>	Diameter <i>Diametro</i>
P 	Worm gearboxes <i>Riduttori a vite senza fine</i>	UNI 	N 	See technical data table <i>Vedi tabelle dati tecnici</i>	0 Hollow Mozzo 	→ Standard I30 MA → ø14 I45 MB → ø18 MC → ø19 MD → ø20 I50 ME → ø24 MF → ø25 I63 MG → ø28 MH → ø30 I85 MK → ø35 I11 MM → ø42 Output male shaft is available only for standard bore <i>Albero maschio in uscita è disponibile solo per fori standard</i>
M 		FLL 	Select L or R position for output flange <i>Selezionare la posizione L o R per la flangia in uscita</i>		S Solid output shaft <i>Albero in uscita</i> 	
B 	I30 I45 I50 I63 I85 I11	BRI Stainless steel <i>Acciaio inox</i> 	L Left <i>Sinistra</i> 			
R 			R Right <i>Destra</i> 			

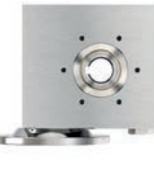
I	N	C	-R	B3	ST	For M type specify terminal box position	
Input / output shaft material <i>Materiale albero in entrata e uscita</i>	Protection cap <i>Coperchio di protezione</i>		Motor size <i>Grandezza motore</i>	Mounting position <i>Posizione di montaggio</i>	Input bore <i>Foro entrata</i>	<i>Per tipo M specificare posizione morsettera</i>	
I Stainless steel <i>Acciaio inox</i> The quill input hollow bore is always in carbon steel <i>Il foro cavo in entrata è sempre in acciaio</i>	Left <i>Sinistra</i>	Right <i>Destra</i>	Motor flanges <i>Flange motore</i>	B3	ST Standard bore* <i>Foro standard*</i>	A	
					Input bore without reduction bushing -O → 9mm -P → 11mm -Q → 14mm -R → 19mm -T → 24mm -U → 28mm		
	N Without protection cap <i>Senza coperchietto di protezione</i>	N Without protection cap <i>Senza coperchietto di protezione</i>	IEC B14 -O → 56 B14 (ø80) -P → 63 B14 (ø90) -Q → 71 B14 (ø105) -R → 80 B14 (ø120) -T → 90 B14 (ø140) -U → 100-112B14 (ø160)	B8		Coupling Standard (IEC) 	B
			Brushless 	B6		-A → 9mm -B → 11mm -C → 14mm -D → 19mm -E → 24mm -F → 28mm	C
C Closed cap <i>Tappo chiuso</i>	C Closed cap <i>Tappo chiuso</i>	BB → 50/70-M5 BC → 60/75-M5 BD → 70/90-M6 BE → 80/100-M6 BF → 95/115-M8 BG → 110/145-M8 BH → 130/165-M8 Brushless-Tech catalogue is available in our website <i>Catalogo Brushless-Tech è disponibile el nostro sito web</i>	B7		Brushless*  -2 → 11mm -3 → 14mm -4 → 19mm -5 → 22mm -6 → 24mm	D	
		Without flange -M → Metric 	V5		Ready for input coupling <i>Predisposto per giunto</i> -0 Type B <i>Tipo B</i> 		
O Open cap <i>Tappo aperto</i>	O Open cap <i>Tappo aperto</i>	Type R <i>Tipo R</i> -0 → Metric 	V6		 * With reduction bushing where applicable <i>* Con bussola di riduzione dove prevista</i>		

Input speed (n_1) = 1400 min⁻¹

Output speed n_2 [min ⁻¹]	Ratio i	Motor power P_{1M} [kW]	Output torque M_{2M} [Nm]	Service factor $f.s$	Nominal power P_{1R} [kW]	Nominal torque M_{2R} [Nm]	B5 motor flanges		B14 motor flanges		Dynamic efficiency RD	Tooth module [mm]	Ratios code
							-	-	-O 56	-P 63			
280	5	0.18	5	3.3	0.60	17			B-C		82	1.26	01
200	7	0.18	7	2.4	0.44	17			B-C		80	1.44	02
140	10	0.18	10	1.8	0.32	17			B-C		78	1.44	03
93	15	0.18	13	1.4	0.25	19			B-C		73	1.44	04
70	20	0.18	17	1.1	0.20	19			B-C		70	1.09	05
47	30	0.12	15	1.4	0.17	21			B-C		62	1.44	06
35	40	0.12	19	1.1	0.13	20			B-C		57	1.09	07
23	61	0.09	19	1.1	0.10	20			B-C		50	0.72	08
17.5	80	0.06	16	1.0	0.06	16			B-C		48	0.56	09
14	100	0.06*	16	0.5	0.03	8			B-C		40	0.45	10

* Power higher than the maximum one which can be supported by the gearbox. Select according to the torque M_{2R} Potenza superiore a quella massima sopportabile dal riduttore. Selezionare in base al momento torcente M_{2R} Motor flanges available
Flange motore disponibiliB) Supplied with reduction bushing
Fornito con bussola di riduzioneB) Available on request without reduction bushing
Disponibile a richiesta senza bussola di riduzioneC) Motor flange holes position
Posizione fori flangia motore

Lubrication

Lubrificazione

Unit I30 is supplied with synthetic oil to assure long life lubrication.

Food grade oil is available on request.

See Table 1 for lubrication and recommended quantity.

See Table 2 for possible radial and axial loads on the gearbox.

Il riduttore tipo I30 viene fornito con olio sintetico e lubrificazione tipo "long life".

Disponibile a richiesta olio alimentare.

Vedi Tabella 1 per oli e quantità consigliati.

Vedi Tabella 2 per i carichi radiali e assiali applicabili al riduttore.

Oil quantity for
all positions:
0.06 LQuantità olio per tutte
le posizioni: 0.06 LShell
Omala S4 WE 320Eni
Telium VSF 320

* For more details on lubrication and plugs check our website.

Tab. 1

* Per maggiori dettagli su lubrificazione e tappi olio vedi il nostro sito web.

Suggested

Suggerito

Stainless steel protection cap
(on request).Coperchio di protezione in
acciaio inox a richiesta.

Kit cod. KI450211



Radial and axial loads

Carichi radiali e assiali

Output shaft

Albero di uscita

n_2 [min ⁻¹]	F_A [N]	F_R [N]
200	120	600
150	140	700
100	160	800
75	180	900
50	200	1000
25	250	1250
15	280	1400

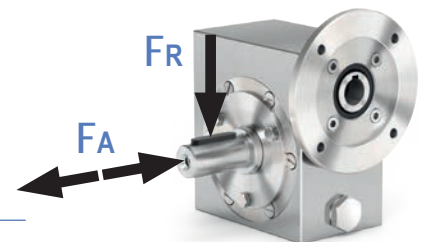

Input shaft

Albero in entrata

n_1 [min ⁻¹]	F_A [N]	F_R [N]
1400	20	100

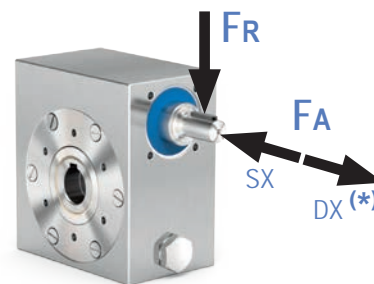

* Strong axial loads in the DX direction are not allowed.

* Non sono consentiti forti carichi assiali con direzione DX

Tab. 2

PI30UNI... **Basic gearbox**
Riduttore base

Gearbox weight
peso riduttore **2.5 kg**

M. flanges	Kit code	øF	A
56B14	KI304046	80	61.5
63B14	KI304045	90	62.5

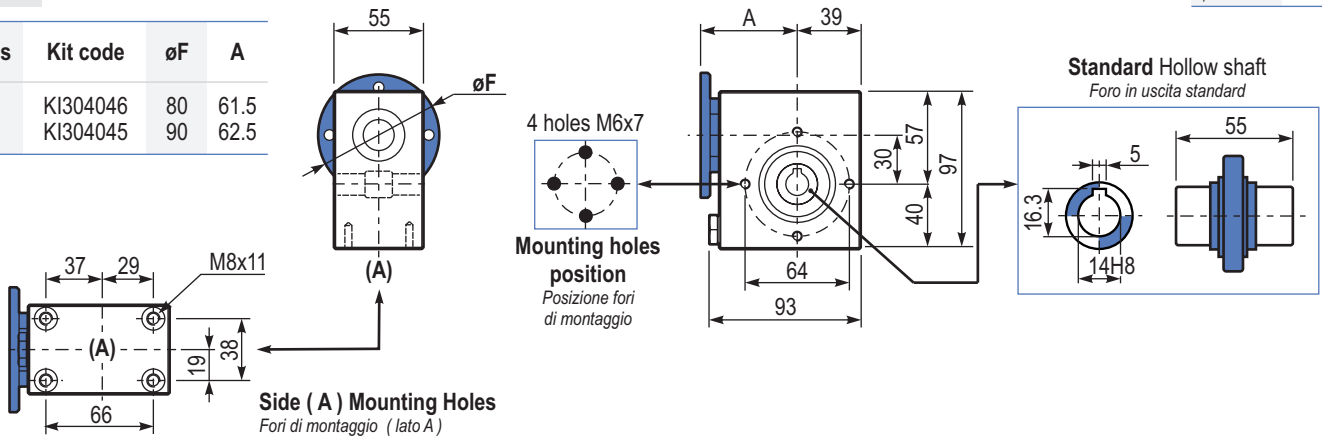

B130UNI... **Modular base**
Base modulare

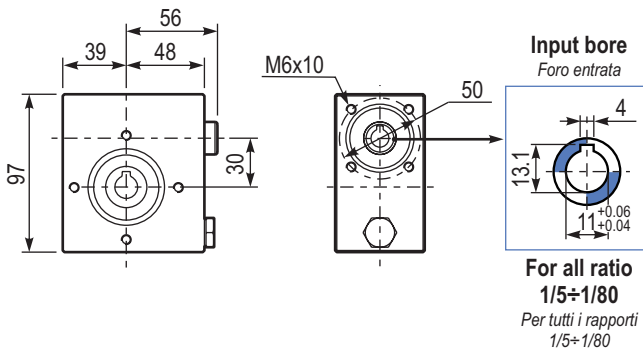

PI30FLL... **Output flange**
Flangia uscita

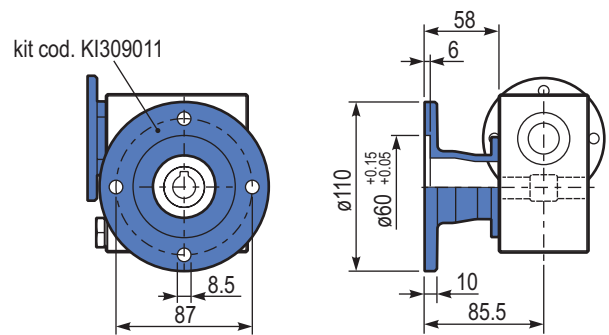

R130UNI... **Input shaft**
Albero in entrata

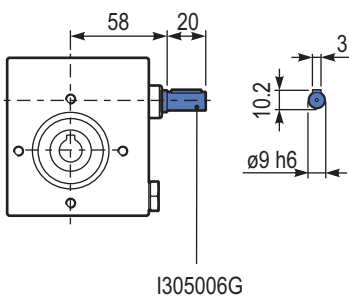

PI30BRI... **Reaction arm**
Braccio di reazione

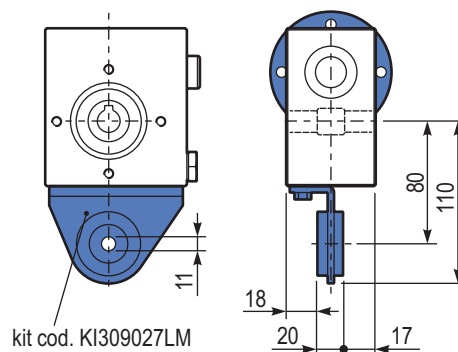

PI30...SMA... **Single Shaft**
Albero lento semplice

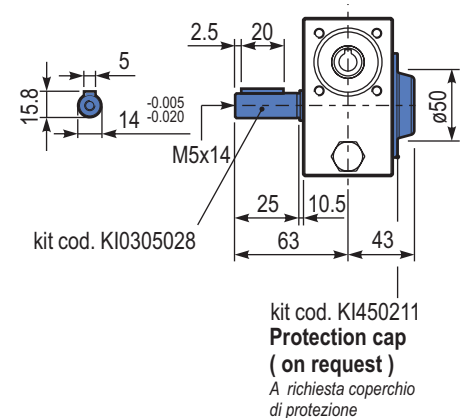

Input speed (n_1) = 1400 min⁻¹

Output speed n_2 [min ⁻¹]	Ratio i	Motor power P_{1M} [kW]	Output torque M_{2M} [Nm]	Service factor $f.s$	Nominal power P_{1R} [kW]	Nominal torque M_{2R} [Nm]	B5 motor flanges		B14 motor flanges		Dynamic efficiency RD	Tooth module [mm]	Ratios code
							-	-	-P 63	-Q 71			
200	7	0.37	14	2.2	0.80	30			B-C		80	2.2	01
140	10	0.37	20	1.5	0.57	30			B-C		79	2.2	02
100	14	0.37	27	1.1	0.41	30			B-C		77	2.4	03
67	21	0.37	36	1.2	0.43	41			B-C		67	1.6	04
50	28	0.25	31	1.3	0.33	41			B-C		65	2.5	05
38	37	0.25	40	1.0	0.26	41			B-C		63	1.8	06
30	46	0.25	46	0.9	0.22	41			B-C		59	1.5	07
23	60	0.18	41	1.0	0.18	41			B-C		56	1.2	08
20	70	0.12	31	1.0	0.12	30			B-C		54	1.0	09
13.7	102	0.12	41	0.7	0.09	29			B-C		49	0.72	10

Motor flanges available
Flange motore disponibili

B) Supplied with reduction bushing
Fornito con bussola di riduzione

B) Available on request without reduction bushing
Disponibile a richiesta senza bussola di riduzione

C) Motor flange holes position
Posizione fori flangia motore

Lubrication

Lubrificazione

Unit I45 is supplied with synthetic oil to assure long life lubrication. Food grade oil is available on request. See Table 1 for lubrication and recommended quantity. See Table 2 for possible radial and axial loads on the gearbox.

Il riduttore tipo I45 viene fornito con olio sintetico e lubrificazione tipo "long life". Disponibile a richiesta olio alimentare. Vedi Tabella 1 per oli e quantità consigliati. Vedi Tabella 2 per i carichi radiali e assiali applicabili al riduttore.

Shell Omala S4 WE 320

Eni Telium VSF 320

B3
Standard
0.15 L

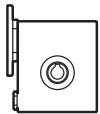

B8
On request
0.15 L

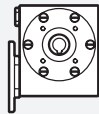

B6
On request
0.15 L

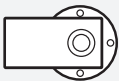

V5
On request
0.15 L

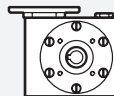

B7
On request
0.20 L

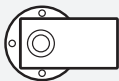

V6
On request
0.15 L

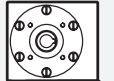

For more details on lubrication and plugs check our website.
Per maggiori dettagli su lubrificazione e tappi olio vedi il nostro sito web.

Tab. 1

Suggested Sugerito

Stainless steel protection cap (on request).
Coperchio di protezione in acciaio inox a richiesta.

Kit cod. KI450211



Radial and axial loads

Carichi radiali e assiali

Output shaft

Albero di uscita

n_2 [min ⁻¹]	FA [N]	FR [N]
200	180	900
150	200	1000
100	220	1100
75	240	1200
50	260	1400
25	300	1800
15	400	2000

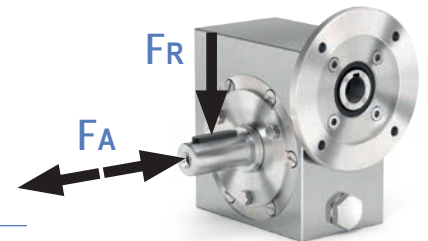

Input shaft

Albero in entrata

n_1 [min ⁻¹]	FA [N]	FR [N]
1400	42	210

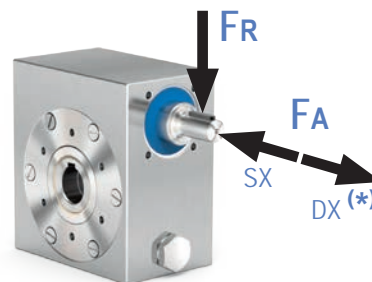

* Strong axial loads in the DX direction are not allowed.
* Non sono consentiti forti carichi assiali con direzione DX

Tab. 2

PI45UNI... **Basic gearbox**
Riduttore base

Gearbox weight
peso riduttore **5.0 kg**

M. flanges	Kit code	øF	A
63B14	KI504047	90	73.5
71B14	KI504045	105	71

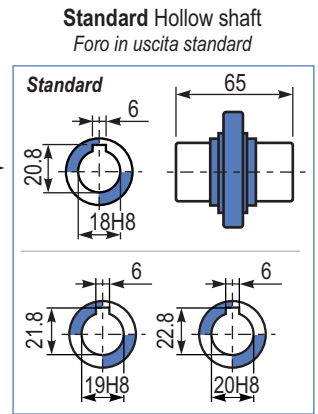
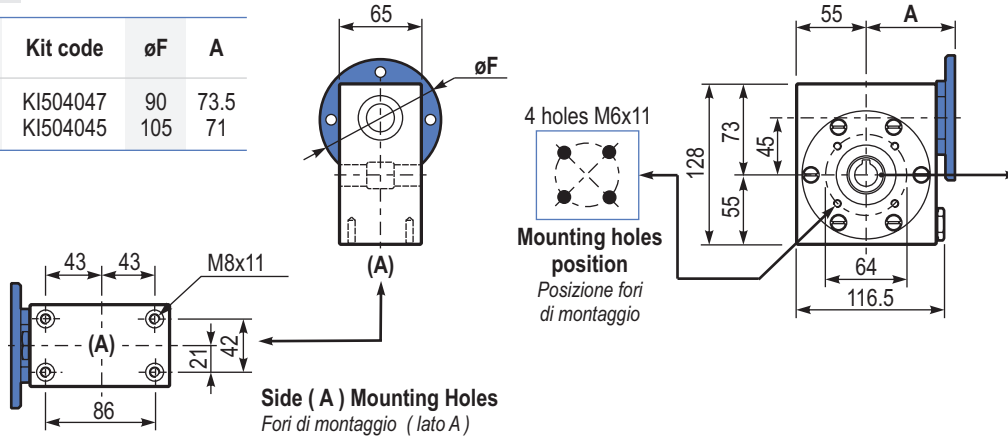

B145UNI... **Modular base**
Base modulare

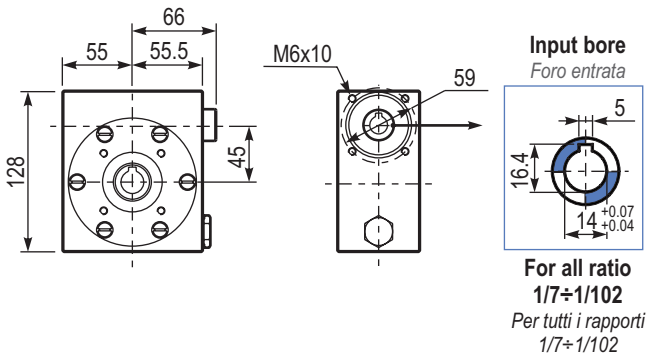

PI45FLL... **Output flange**
Flangia uscita

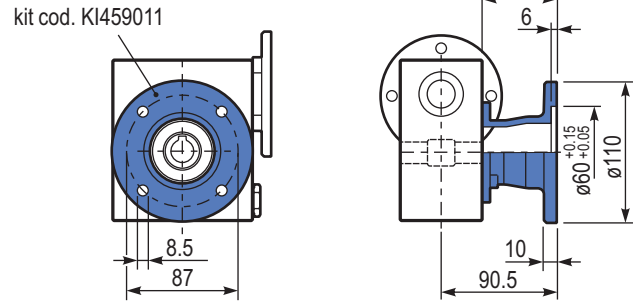

R145UNI... **Input shaft**
Albero in entrata

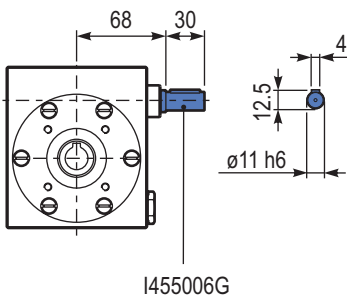

PI45BRI... **Reaction arm**
Braccio di reazione

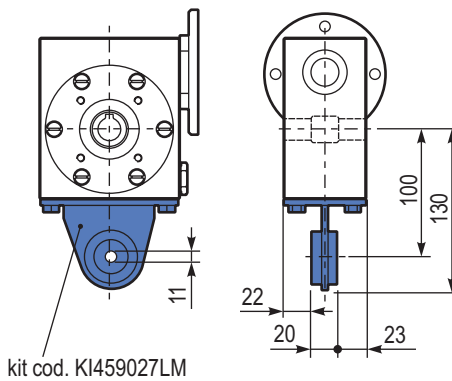

PI45...SMB... **Single Shaft**
Albero lento semplice

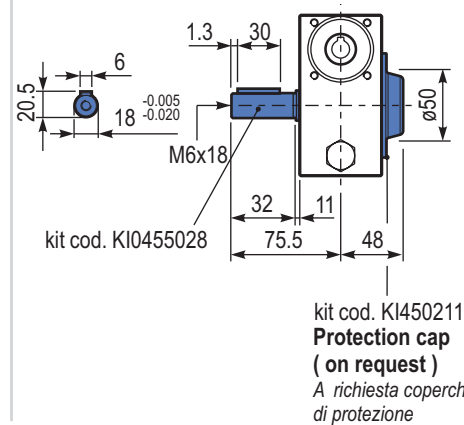

Input speed (n_1) = 1400 min⁻¹

Output speed n_2 [min ⁻¹]	Ratio i	Motor power P_{1M} [kW]	Output torque M_{2M} [Nm]	Service factor f_s	Nominal power P_{1R} [kW]	Nominal torque M_{2R} [Nm]	B5 motor flanges			B14 motor flanges			Dynamic efficiency RD	Tooth module [mm]	Ratios code
							-	-	-	-P 63	-Q 71	-R 80			
200	7	0.75	29	1.9	1.5	57				B-C	B		82	2.5	01
140	10	0.75	41	1.5	1.1	62				B-C	B		80	2.4	02
100	14	0.75	57	1.2	0.90	68				B-C	B		79	2.6	03
78	18	0.55	51	1.2	0.67	62				B-C	B		75	2.0	04
54	26	0.55	67	1.0	0.54	66				B-C	B		69	2.7	05
47	30	0.55	79	0.9	0.50	72				B-C	B		70	2.5	12
39	36	0.37	63	1.2	0.43	72				B-C			69	2.1	06
33	43	0.37	72	1.0	0.35	68				B-C			66	1.8	07
28	50	0.25	53	1.2	0.31	66				B-C			62	1.5	13
23	60	0.25	59	1.0	0.26	62				B-C			58	1.3	08
21	68	0.25	66	0.9	0.22	58				B-C			57	1.2	09
17.5	80	0.18	53	1.1	0.19	57				B-C			54	1.0	10
14	100	0.12	41	1.3	0.15	51				B-C			50	0.8	11

Motor flanges available
Flange motore disponibili



B) Supplied with reduction bushing
Fornito con bussola di riduzione



B) Available on request without reduction bushing
Disponibile a richiesta senza bussola di riduzione



C) Motor flange holes position
Posizione fori flangia motore

Lubrication

Lubrificazione

Unit 150 is supplied with synthetic oil to assure long life lubrication. Food grade oil is available on request. See Table 1 for lubrication and recommended quantity. See Table 2 for possible radial and axial loads on the gearbox.

Il riduttore tipo 150 viene fornito con olio sintetico e lubrificazione tipo "long life". Disponibile a richiesta olio alimentare. Vedi Tabella 1 per oli e quantità consigliati. Vedi Tabella 2 per i carichi radiali e assiali applicabili al riduttore.

Shell Omala S4 WE 320

Eni Telium VSF 320

B3
Standard
0.22 L

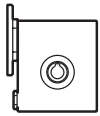

B8
On request
0.22 L

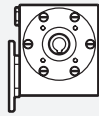

B6
On request
0.22 L

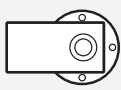

V5
On request
0.22 L

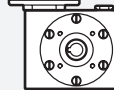

B7
On request
0.28 L

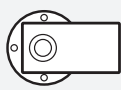

V6
On request
0.22 L

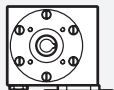

For more details on lubrication and plugs check our website. Per maggiori dettagli su lubrificazione e tappi olio vedi il nostro sito web.

Tab. 1

Suggested Sugerito

Stainless steel protection cap (on request). Coperchio di protezione in acciaio inox a richiesta.

Kit cod. KI500211



Radial and axial loads

Carichi radiali e assiali

Output shaft

Albero di uscita

n_2 [min ⁻¹]	FA [N]	FR [N]
200	240	1200
150	280	1400
100	300	1500
75	340	1700
50	380	1900
25	480	2500
15	560	2800

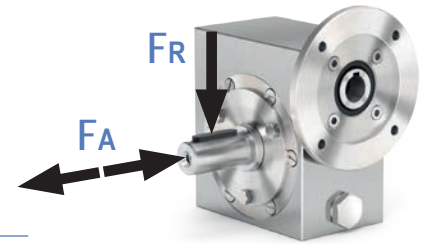

Input shaft

Albero in entrata

n_1 [min ⁻¹]	FA [N]	FR [N]
1400	76	380

* Strong axial loads in the DX direction are not allowed.

* Non sono consentiti forti carichi assiali con direzione DX

Tab. 2

PI50UNI... **Basic gearbox**
Riduttore base

Gearbox weight
peso riduttore **7.3 kg**

M. flanges	Kit code	øF	A
63B14	KI504047	90	78
71B14	KI504045	105	75.5
80B14	KI504046	120	76

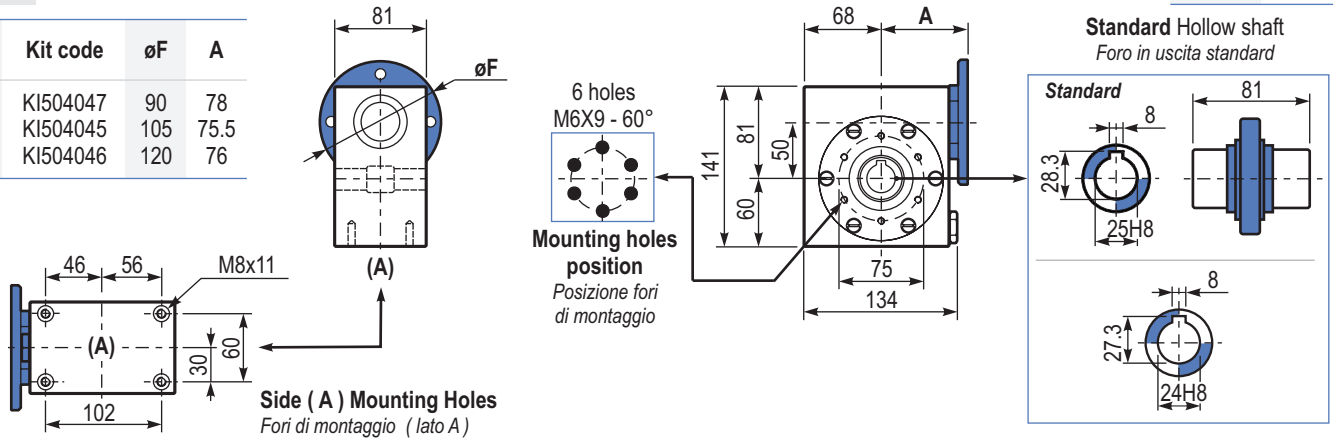

BI50UNI... **Modular base**
Base modulare

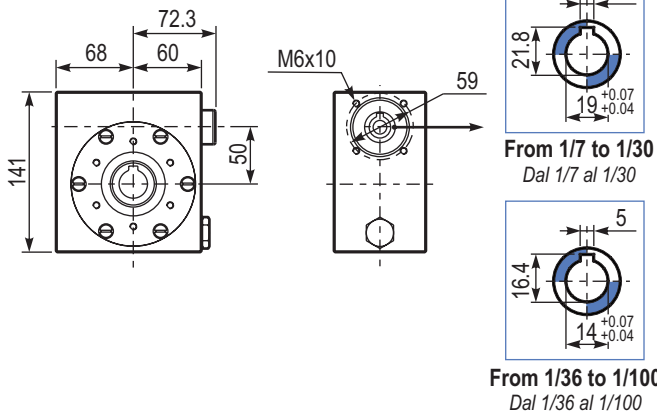

PI50FLL... **Output flange**
Flangia uscita

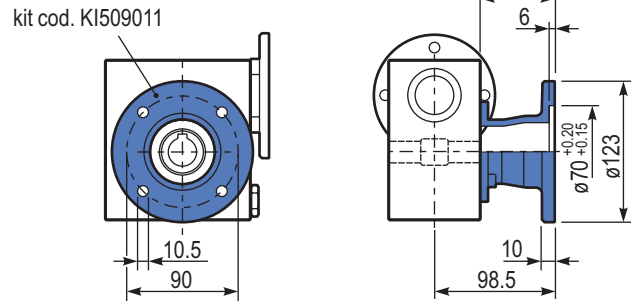

RI50UNI... **Input shaft**
Albero in entrata

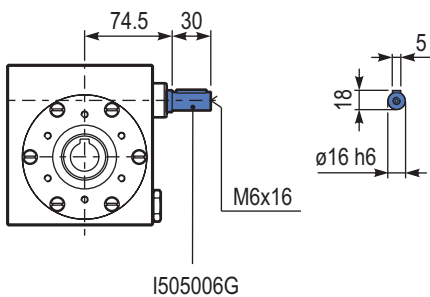

PI50BRI... **Reaction arm**
Braccio di reazione

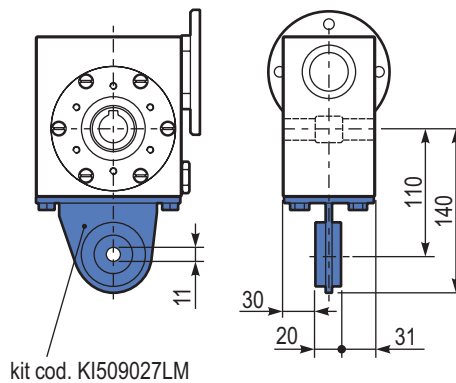

PI50...SMF.. **Single Shaft**
Albero lento semplice

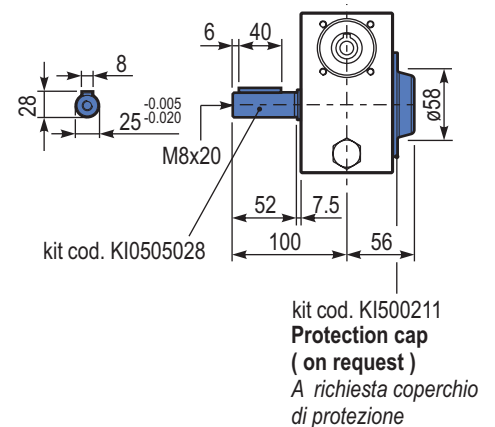

Input speed (n_1) = 1400 min⁻¹

Output speed n_2 [min ⁻¹]	Ratio i	Motor power P_{1M} [kW]	Output torque M_{2M} [Nm]	Service factor $f.s$	Nominal power P_{1R} [kW]	Nominal torque M_{2R} [Nm]	B5 motor flanges			B14 motor flanges			Dynamic efficiency RD	Tooth module [mm]	Ratios code
							-	-	-	-Q	-R	-T			
200	7	1.8	71	1.8	3.2	125	-	-	-	71	80	90	83	3.1	01
140	10	1.8	99	1.4	2.4	134	-	-	-	B-C	B-C		81	3.1	02
93	15	1.5	121	1.1	1.7	138	-	-	-	B-C	B-C		79	3.1	03
74	19	1.1	111	1.2	1.4	138	-	-	-	B-C	B-C		78	2.6	04
58	24	1.1	135	1.0	1.2	142	-	-	-	B-C	B-C		75	2.0	05
47	30	1.1	167	0.9	0.96	146	-	-	-	B-C	B-C		74	3.2	06
39	36	0.75	125	1.2	0.88	147	-	-	-	B-C	B-C		68	2.7	07
35	40	0.75	135	1.0	0.78	140	-	-	-	B-C	B-C		66	2.5	13
31	45	0.55	111	1.2	0.67	135	-	-	-	B-C	C		66	2.1	08
23	60	0.55	140	0.9	0.51	130	-	-	-	B-C	C		62	1.6	12
21	67	0.55	151	0.8	0.45	124	-	-	-	B-C	C		60	1.5	09
17.5	80	0.37	115	1.0	0.38	119	-	-	-	B-C	C		57	1.3	10
14.9	94	0.37	123	1.0	0.36	119	-	-	-	B-C	C		52	1.1	11

Motor flanges available
Flange motore disponibili



B) Supplied with reduction bushing
Fornito con bussola di riduzione



B) Available on request without reduction bushing
Disponibile a richiesta senza bussola di riduzione



C) Motor flange holes position
Posizione fori flangia motore

Lubrication

Lubrificazione

Unit 163 is supplied with synthetic oil to assure long life lubrication. Food grade oil is available on request. See Table 1 for lubrication and recommended quantity. See Table 2 for possible radial and axial loads on the gearbox.

Il riduttore tipo 163 viene fornito con olio sintetico e lubrificazione tipo "long life". Disponibile a richiesta olio alimentare. Vedi Tabella 1 per oli e quantità consigliati. Vedi Tabella 2 per i carichi radiali e assiali applicabili al riduttore.

Shell Omala S4 WE 320

Eni Telium VSF 320

B3
Standard
0.60 L

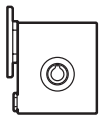

B8
On request
0.60 L

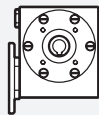

B6
On request
0.60 L

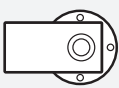

V5
On request
0.60 L

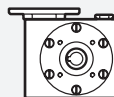

B7
On request
0.82 L

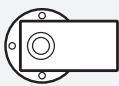

V6
On request
0.60 L

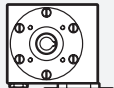

For more details on lubrication and plugs check our website.
Per maggiori dettagli su lubrificazione e tappi vedi il nostro sito web.

Tab. 1

Suggested Sugerito

Stainless steel protection cap (on request).
Coperchio di protezione in acciaio inox a richiesta.

Kit cod. KI630211



Radial and axial loads

Carichi radiali e assiali

Output shaft

Albero di uscita

n_2 [min ⁻¹]	FA [N]	FR [N]
200	360	1800
150	400	2000
100	460	2300
75	500	2500
50	600	3000
25	700	3800
15	800	4000

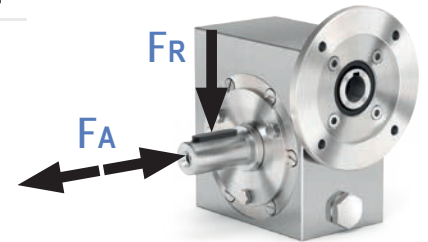

Input shaft

Albero in entrata

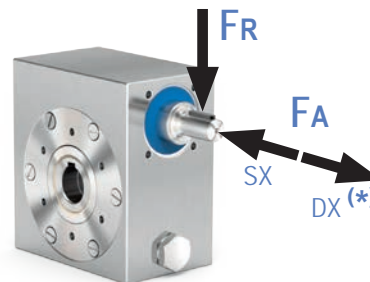

n_1 [min ⁻¹]	FA [N]	FR [N]
1400	90	450

* Strong axial loads in the DX direction are not allowed.
* Non sono consentiti forti carichi assiali con direzione DX

Tab. 2

PI63UNI... **Basic gearbox**
Riduttore base

Gearbox weight
peso riduttore **14.6 kg**

M. flanges	Kit code	øF	A
71B14	KI634047	105	97
80B14	KI634046	120	99
90B14	KI634041	140	99

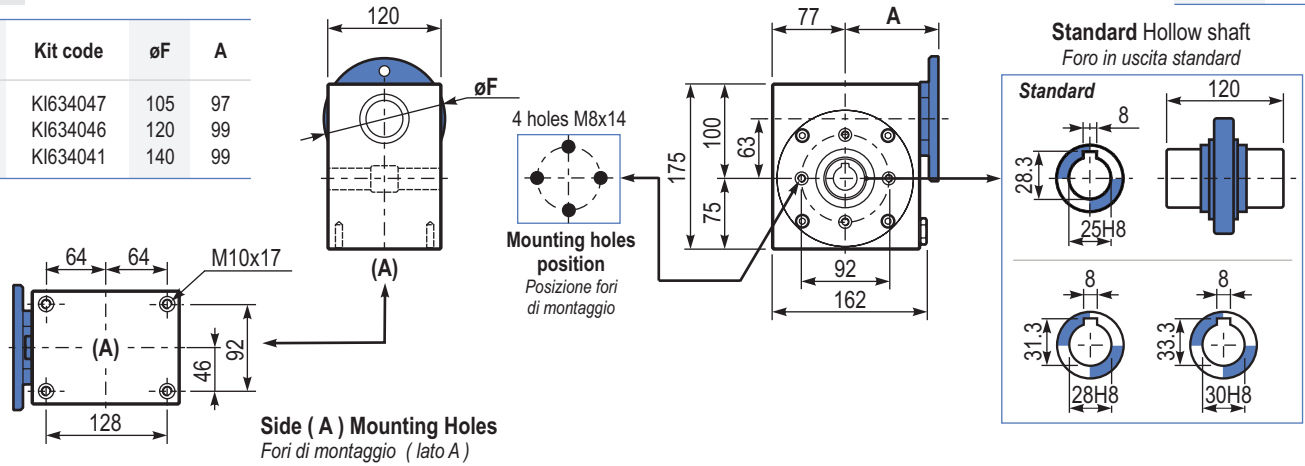

BI63UNI... **Modular base**
Base modulare

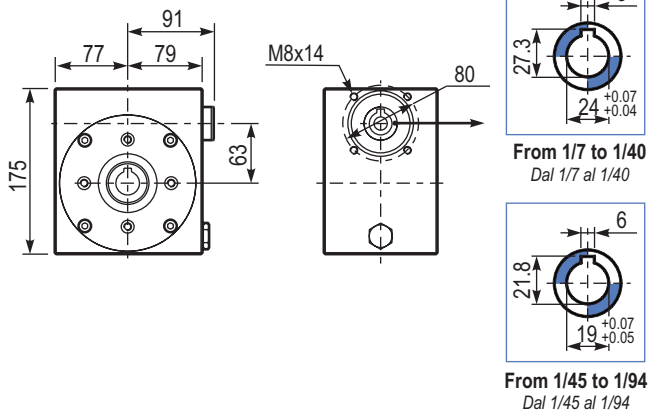

PI63FLL... **Output flange**
Flangia uscita

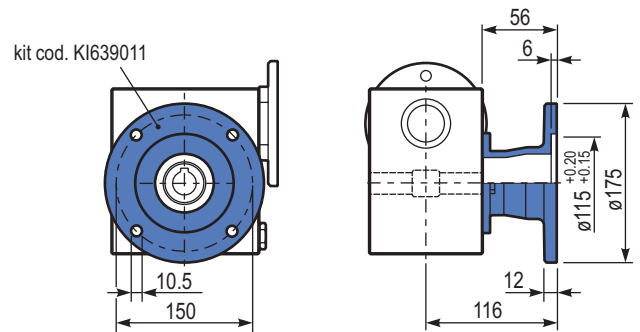

RI63UNI... **Input shaft**
Albero in entrata

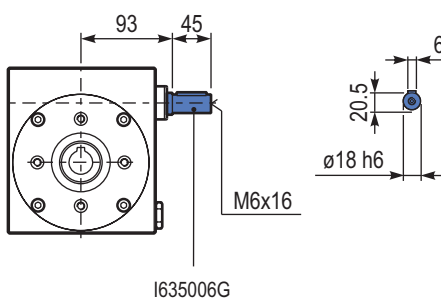

PI63BRI... **Reaction arm**
Braccio di reazione

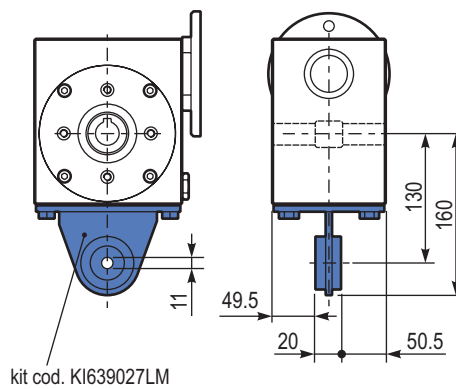

PI63...SMF... **Single Shaft**
Albero lento semplice

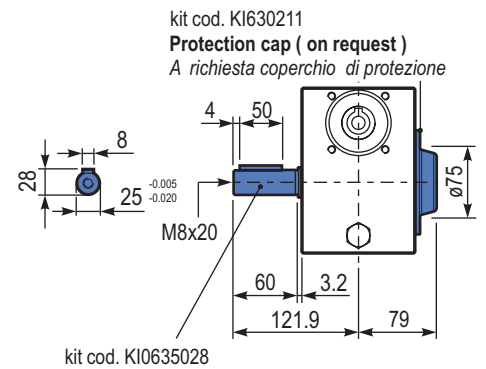

Input speed (n_1) = 1400 min⁻¹

Output speed n_2 [min ⁻¹]	Ratio i	Motor power P_{1M} [kW]	Output torque M_{2M} [Nm]	Service factor f_s	Nominal power P_{1R} [kW]	Nominal torque M_{2R} [Nm]	B5 motor flanges			B14 motor flanges			Dynamic efficiency RD	Tooth module [mm]	Ratios code
							-	-	-	-R	-T	-U			
200	7	4.0	168	1.5	6.1	257	-	-	-	B	B		88	4.23	01
140	10	4.0	218	1.3	5.2	284	-	-	-	B	B		80	4.2	02
100	14	3.0	223	1.4	4.1	305	-	-	-	B	B		78	4.5	03
70	20	2.2	237	1.2	2.7	294	-	-	-	B	B		79	3.4	04
64	22	2.2	258	1.1	2.5	294	-	-	-	B	B		78	3.1	05
50	28	2.2	315	1.1	2.4	347	-	-	-	B	B		75	4.7	06
37	38	1.5	276	1.2	1.8	336	-	-	-	B	B		71	3.5	07
30	46	1.5	320	1.0	1.5	326	-	-	-	B			68	3.1	08
27	52	1.1	258	1.1	1.2	289	-	-	-	B			66	2.7	09
21	67	1.1	327	0.9	0.97	289	-	-	-	B			65	2.1	10
18.9	74	0.75	220	1.2	0.91	268	-	-	-	B			58	1.9	11
14.6	96	0.55	191	1.3	0.70	242	-	-	-	B			53	1.5	12

Motor flanges available
Flange motore disponibili



B) Supplied with reduction bushing
Fornito con bussola di riduzione



B) Available on request without reduction bushing
Disponibile a richiesta senza bussola di riduzione



C) Motor flange holes position
Posizione fori flangia motore

Lubrication

Lubrificazione

Unit I85 is supplied with synthetic oil to assure long life lubrication. Food grade oil is available on request. See Table 1 for lubrication and recommended quantity. See Table 2 for possible radial and axial loads on the gearbox.

Il riduttore tipo I85 viene fornito con olio sintetico e lubrificazione tipo "long life". Disponibile a richiesta olio alimentare. Vedi Tabella 1 per oli e quantità consigliati. Vedi Tabella 2 per i carichi radiali e assiali applicabili al riduttore.

Shell Omala S4 WE 320

Eni Telium VSF 320

B3
Standard
1.40 L

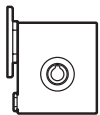

B8
On request
1.40 L

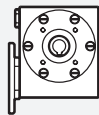

B6
On request
1.40 L

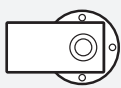

V5
On request
1.40 L

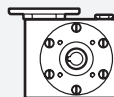

B7
On request
1.70 L

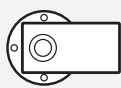

V6
On request
1.40 L



For more details on lubrication and plugs check our website. Per maggiori dettagli su lubrificazione e tappi olio vedi il nostro sito web.

Tab. 1

Suggested Sugerito

Stainless steel protection cap (on request). Coperchio di protezione in acciaio inox a richiesta.

Kit cod. KI850211



Radial and axial loads

Carichi radiali e assiali

Output shaft

Albero di uscita

n_2 [min ⁻¹]	FA [N]	FR [N]
200	500	2500
150	580	2900
100	600	3000
75	700	3500
50	800	4000
25	1000	5000
15	1160	5800

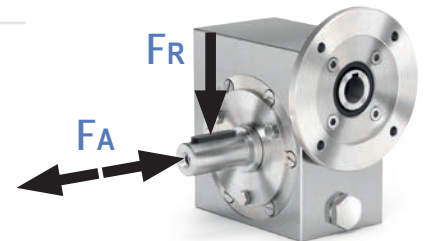

Input shaft

Albero in entrata

n_1 [min ⁻¹]	FA [N]	FR [N]
1400	130	650

* Strong axial loads in the DX direction are not allowed. * Non sono consentiti forti carichi assiali con direzione DX

Tab. 2

PI85UNI... **Basic gearbox**
Riduttore base

Gearbox weight
peso riduttore **23.3 kg**

M. flanges	Kit code	øF	A
80B14	KI854046	120	118
90B14	KI854045	140	118
100-112B14	KI854041	160	127

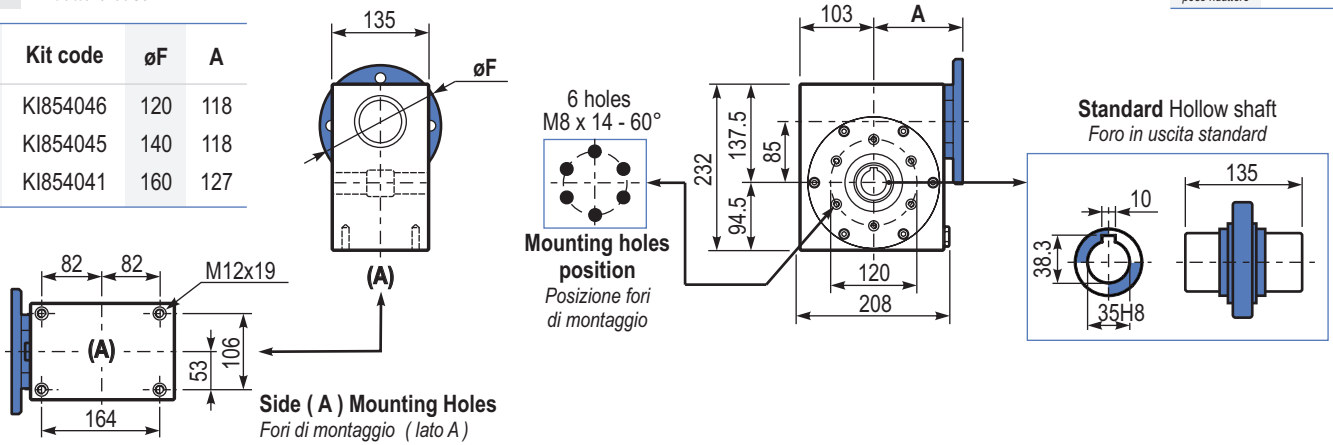

Side (A) Mounting Holes
Fori di montaggio (lato A)

Standard Hollow shaft
Foro in uscita standard

BI85UNI... **Modular base**
Base modulare

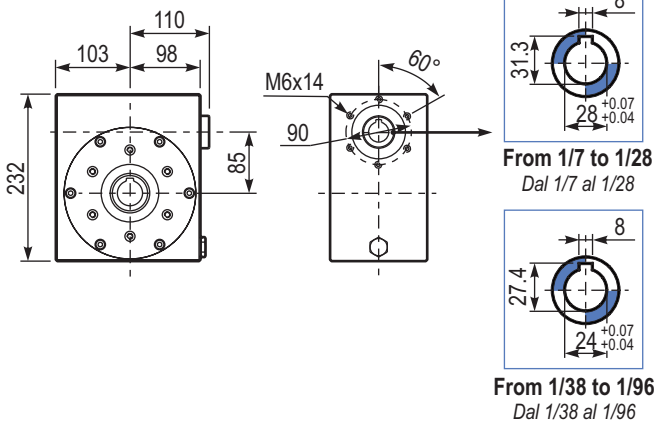

PI85FLL... **Output flange**
Flangia uscita

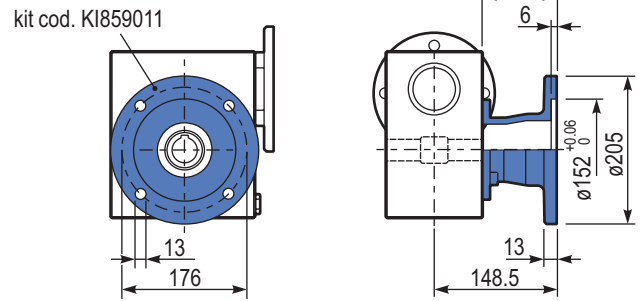

RI85UNI... **Input shaft**
Albero in entrata

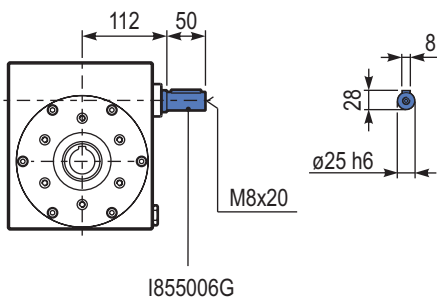

PI85BRI... **Reaction arm**
Braccio di reazione

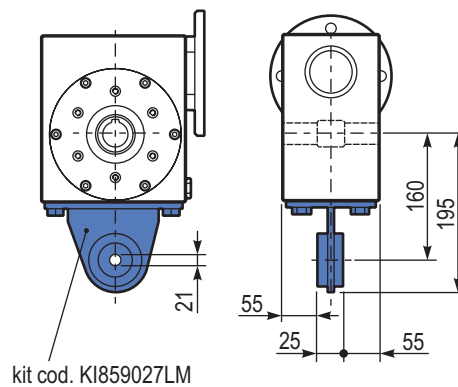

PI85...SMK... **Single Shaft**
Albero lento semplice

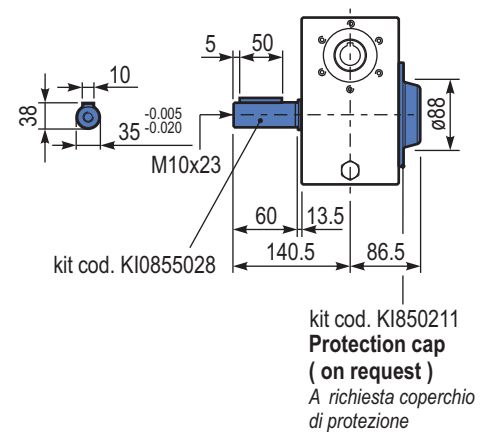

Input speed (n_1) = 1400 min⁻¹

Output speed n_2 [min ⁻¹]	Ratio i	Motor power P_{1M} [kW]	Output torque M_{2M} [Nm]	Service factor $f.s$	Nominal power P_{1R} [kW]	Nominal torque M_{2R} [Nm]	B5 motor flanges			B14 motor flanges			Dynamic efficiency RD	Tooth module [mm]	Ratios code
							-	-	-	-R	-T	-U			
200	7	4.0	168	2.9	11.5	483	-	-	-	B	B		88	5.5	01
140	10	4.0	235	2.2	9.0	525	-	-	-	B	B		86	5.4	02
88	16	4.0	358	1.5	6.0	536	-	-	-	B	B		82	5.3	03
70	20	4.0	447	1.2	4.9	546	-	-	-	B	B		82	4.5	04
61	23	3.0	377	1.4	4.1	515	-	-	-	B	B		80	3.9	05
47	30	3.0	467	1.4	4.2	651	-	-	-	B	B		76	5.6	06
37	38	3.0	583	1.1	3.3	641	-	-	-	B	B		75	4.7	07
31	45	2.2	493	1.2	2.7	599	-	-	-	B	B		73	4.0	08
26	53	2.2	557	1.1	2.5	620	-	-	-	B	B		70	3.5	09
22	64	1.5	452	1.2	1.8	536	-	-	-	B	B		69	2.9	10
16.7	84	1.1	410	1.2	1.3	494	-	-	-	B	B		65	2.2	11
14.1	99	1.1	446	1.1	1.2	483	-	-	-	B	B		60	1.9	12

Motor flanges available Flange motore disponibili
 B) Supplied with reduction bushing Fornito con bussola di riduzione
 B) Available on request without reduction bushing Disponibile a richiesta senza bussola di riduzione
 C) Motor flange holes position Posizione fori flangia motore

Lubrication

Lubrificazione

Unit I11 is supplied with synthetic oil to assure long life lubrication. Food grade oil is available on request. See Table 1 for lubrication and recommended quantity. See Table 2 for possible radial and axial loads on the gearbox.

Il riduttore tipo I11 viene fornito con olio sintetico e lubrificazione tipo "long life". Disponibile a richiesta olio alimentare. Vedi Tabella 1 per oli e quantità consigliati. Vedi Tabella 2 per i carichi radiali e assiali applicabili al riduttore.

Shell **Omala S4 WE 320** Eni **Telium VSF 320**

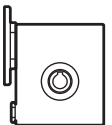
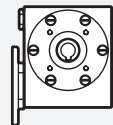
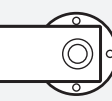
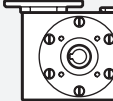
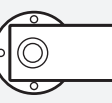
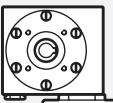
B3 Standard 3.50 L		B8 On request 2.10 L	
B6 On request 2.50 L		V5 On request 1.60 L	
B7 On request 2.50 L		V6 On request 1.60 L	

For more details on lubrication and plugs check our website. Per maggiori dettagli su lubrificazione e tappi olio vedi il nostro sito web.

Tab. 1

Radial and axial loads

Carichi radiali e assiali

Output shaft

Albero di uscita

n_2 [min ⁻¹]	F_A [N]	F_R [N]
200	600	2900
150	700	3300
100	750	3600
75	800	4000
50	920	4600
25	1200	6000
15	1400	7000

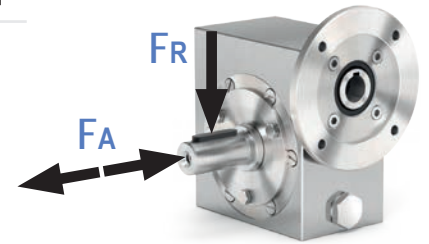

Input shaft

Albero in entrata

n_1 [min ⁻¹]	F_A [N]	F_R [N]
1400	228	1140

* Strong axial loads in the DX direction are not allowed. * Non sono consentiti forti carichi assiali con direzione DX

Tab. 2

PI11UNI... **Basic gearbox**
Riduttore base

Gearbox weight
peso riduttore **38.5 kg**

M. flanges	Kit code	øF	A
80B14	KI854046	120	137.5
90B14	KI854045	140	137.5
100-112B14	KI854041	160	146.5

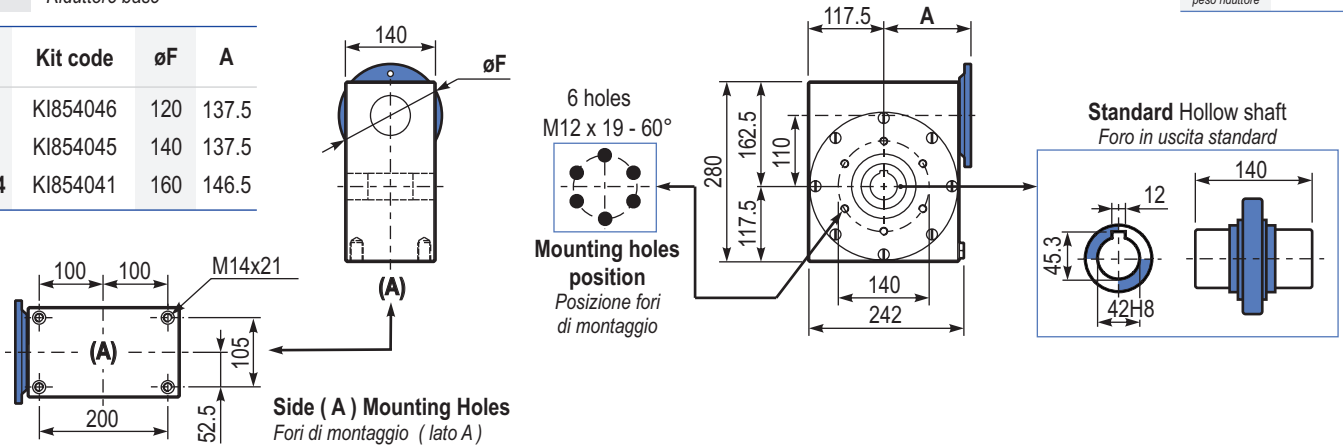

B111UNI... **Modular base**
Base modulare

PI11BRI... **Reaction arm**
Braccio di reazione

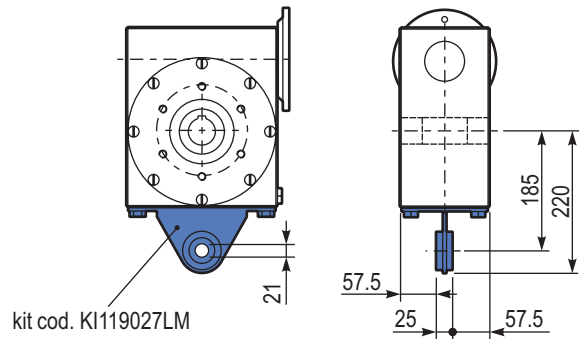
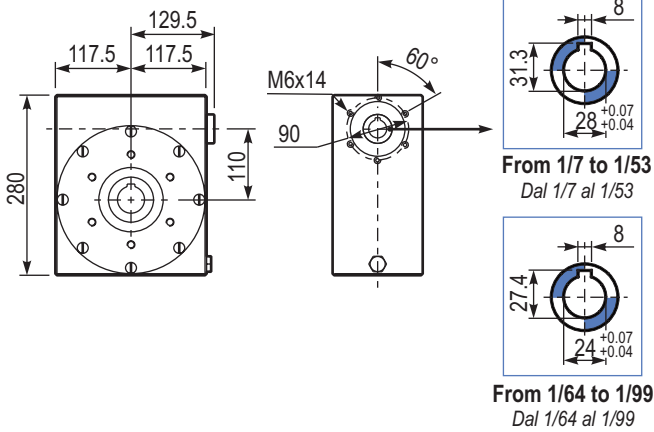

R111UNI... **Input shaft**
Albero in entrata

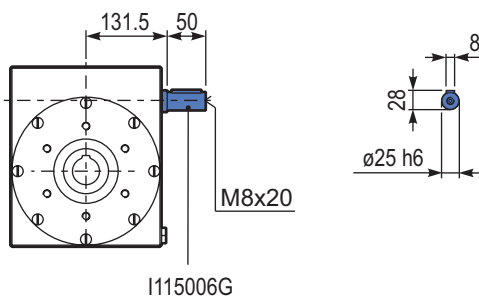



RCI series Full stainless steel ratio multipliers

Riduttori ad uno stadio completamente in acciaio inox

Section **7**
Sezione 7

AISI 304

IP66

CE





NSF







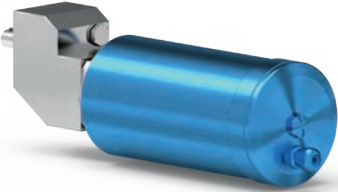
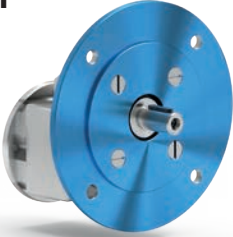



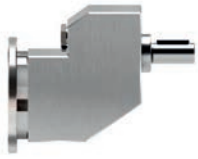

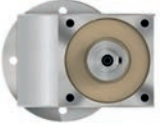
COMPONENT

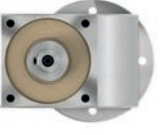
On req.
A rich.





How to order *Codifica*

P	411I	-F	1.57	C
Type <i>Tipo</i>	Size <i>Grandezza</i>	Mounting <i>Montaggio</i>	Ratio <i>Rapporto</i>	Output shaft <i>Albero lento</i>
P 	411I	-N 	See technical data table <i>Vedi tabelle dati tecnici</i>	
M 		-F 		→ Standard C → $\varnothing 19$
B 				

4	-T	B3	ST	For M type specify terminal box position
Output flange <i>Flangia uscita</i>	Motor size <i>Grandezza motore</i>	Mounting position <i>Posizione di montaggio</i>	Input bore <i>Foro entrata</i>	<i>Per tipo M specificare posizione morsettiera</i>
 <p>N Without flange <i>Senza flangia</i></p> <p>4 → ø200</p>	Motor flanges <i>Flange motore</i>	B3 	ST Standard bore <i>Foro standard</i>	A 
		B6 		B 
	IEC B14 -Q → 71 B14 (ø105) -R → 80 B14 (ø120) -T → 90 B14 (ø140)	B7 		C 
	Without flange <i>Senza flangia</i>	B8 		D 
		V5 		
	-1 → ø14 (IEC 71) -2 → ø19 (IEC 80) -3 → ø24 (IEC 90)	V6 		
		V8 		

The dynamic efficiency is **0.98** for all ratios

Input speed (n_1) = 1400 min⁻¹

Output speed n_2 [min ⁻¹]	Ratio i	Motor power P_{1M} [kW]	Output torque M_{2M} [Nm]	Service factor $f.s$	Nominal power P_{1R} [kW]	Nominal torque M_{2R} [Nm]	B5 motor flanges		B14 motor flanges			Output shaft 	Ratios code 
							-	-	-Q 71	-R 80	-T 90		
891	1.57	1.5	16	1.3	1.9	20			C	C		2844	01
493	2.84	1.5	28	1.2	1.8	35			C	C		1954	02
425	3.29	1.5	33	1.2	1.7	38			C	C		1756	03
362	3.87	1.5	39	1.0	1.5	40			C	C		1558	04
303	4.62	1.5	46	1.0	1.5	47			C	C		1360	05
222	6.30	1.1	46	1.0	1.1	46			C	C		1063	06
170	8.22	0.55	30	1.3	0.69	38			C	C		974	07
129	10.86	0.37	27	1.0	0.39	28			C	C		776	08

Motor flanges available
Flange motore disponibili



B) Supplied with reduction bushing
Fornito con bussola di riduzione



B) Available on request without reduction bushing
Disponibile a richiesta senza bussola di riduzione



C) Motor flange holes position
Posizione fori flangia motore

Lubrication

Lubrificazione

Unit 4111 is supplied with synthetic oil to assure long life lubrication.
Food grade oil is available on request.

See Table 1 for lubrication and recommended quantity.

See Table 2 for possible radial and axial loads on the gearbox.

Il riduttore tipo 4111 viene fornito con olio sintetico e lubrificazione tipo "long life".

Disponibile a richiesta olio alimentare.

Vedi Tabella 1 per oli e quantità consigliati.

Vedi Tabella 2 per i carichi radiali e assiali applicabili al riduttore.

Oil quantity for all positions: 0.14 L <i>Quantità olio per tutte le posizioni: 0.14 L</i>	Shell <i>Omala S4 WE 320</i>	Eni <i>Telium VSF 320</i>
--	---------------------------------	------------------------------

Radial and axial loads

Carichi radiali e assiali

Output shaft

Albero di uscita

n_2 [min ⁻¹]	F_A [N]	F_R [N]
700	182	910
600	200	1000
400	230	1150
300	250	1250
200	290	1450
140	320	1600

$$F_{eq} = F_R \cdot \frac{48.5}{X + 28.5}$$

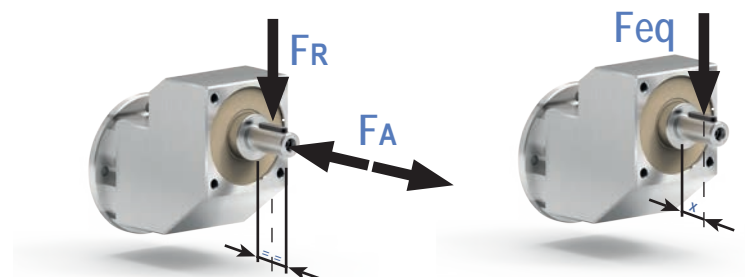

Tab. 1

Tab. 2

P4111-N... **Basic gearbox**
Riduttore base

Gearbox weight
peso riduttore **5.5 kg**

Output shafts / albero di uscita

	Shaft - d1	p1	h1	x
Standard	ø19x40	6	21.5	M6x16

Input flanges / flange di entrata

	Kit code	k1	g6
71 B14	KI634047	128.5	105
80 B14	KI634046	130.5	120
90 B14	KI634041	130.5	140

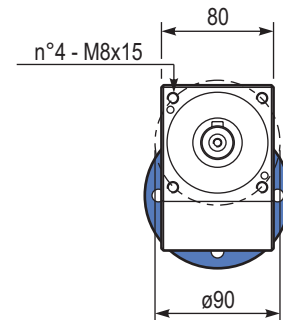
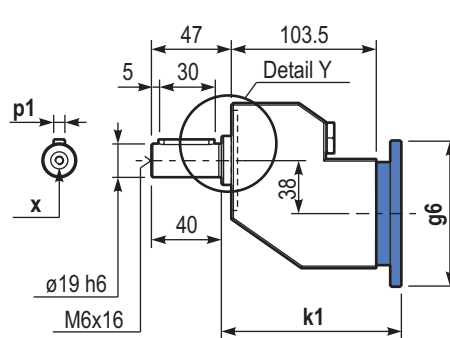
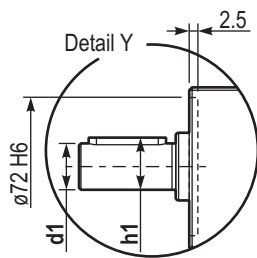

P4111-F... **Output flange**
Flangia di uscita

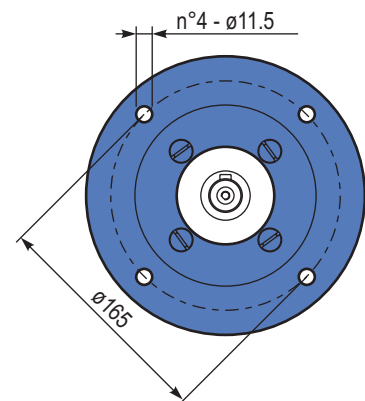
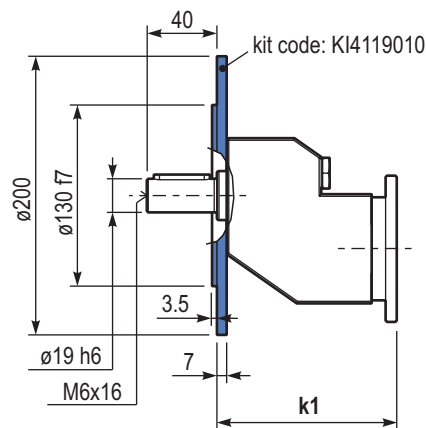



For the complete documentation please visit our website: www.cleangeartech.com

Per la documentazione completa si prega di visitare il nostro sito web: www.cleangeartech.com

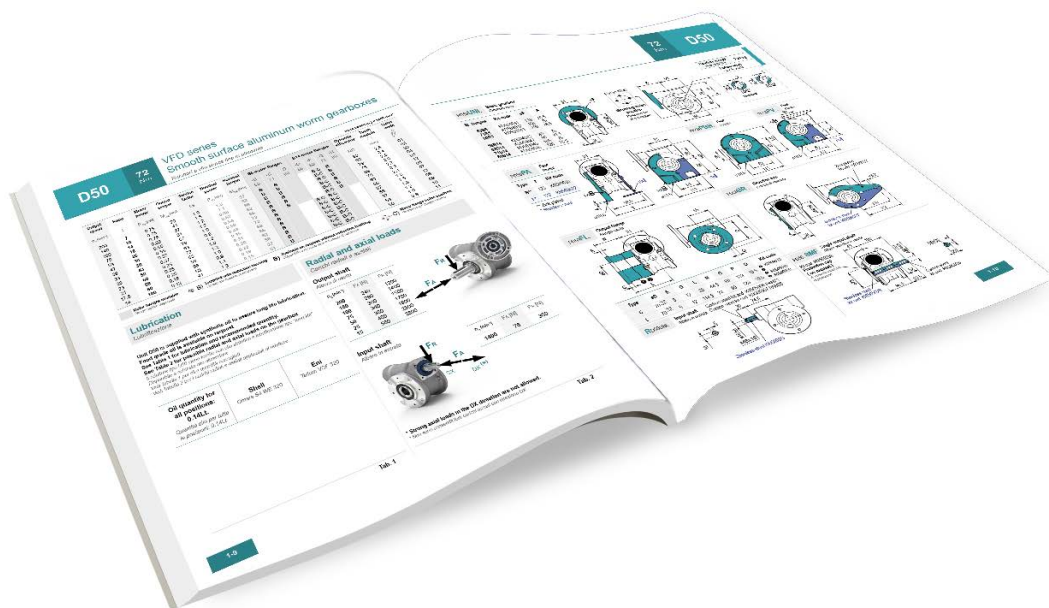

Radial loads
Carichi radiali

Pag. 8-2

Notes on protective white paint
Note sulla vernice bianca protettiva

Pag. 8-3

Suggestions on application of the gearboxes
Suggerimenti sull'applicazione dei riduttori

Pag. 8-4

Section 8

Sezione 8

How to select a gearbox

Come selezionare un riduttore

A Select required torque (according to service factor)
Seleziona la coppia desiderata (comprensiva del fattore di servizio)

C Select gear ratio in the line corresponding to the chosen motor power
Sulla riga corrispondente alla motorizzazione prescelta si può rilevare il rapporto

B Select output speed
Seleziona la velocità in uscita

D Select motor flange available (if requested)
Scegli la flangia disponibile (se richiesta)

Worm gearboxes

Technical data example Esempio di dati tecnici

Output speed n_2 [min ⁻¹]	Ratio i	Motor power P_{1M} [kW]	Output torque M_{2M} [Nm]	Service factor f.s	Nominal power P_{1R} [kW]	Nominal torque M_{2R} [Nm]	Flange code Codice flangia				Dynamic efficiency Rendimento dinamico	Nominal module Modulo nominale	Input speed Velocità in entrata n_1 [min ⁻¹]	Tooth module [mm]	Ratio code
							B5 motor flanges		B14 motor flanges						
280	5	0.18	5	3.3	0.60	17	-A 56	-B 63	-O 56	-P 63	RD	82	1.26	09	
200	7	0.18	7	2.4	0.44	17	B		B-C		80	1.44	01		
140	10	0.18	10	1.8	0.32	17	B		B-C		78	1.44	02		
93	15	0.18	13	1.4	0.25	19	B		B-C		73	1.44	03		



Type of load and starts per hour Tipo di carico e avviamenti per ora	Worm gearboxes Vite senza fine			
Operating hours per day - Ore di funzionamento giornaliero	<2h	2÷8h	8÷16h	
Continuous or intermittent application with start / hour Applicazione continua o intermittente con numero operazioni/ora ≤ 10	Uniform - <i>Uniforme</i>	0.9	1	1.25
	Moderate - <i>Moderato</i>	1	1.25	1.5
	Heavy - <i>Forte</i>	1.25	1.5	1.75
Intermittent application with start / hour Applicazione intermittente con numero operazioni/ora > 10	Uniform - <i>Uniforme</i>	1.25	1.5	1.75
	Moderate - <i>Moderato</i>	1.5	1.75	2
	Heavy - <i>Forte</i>	1.75	2	2.25

Ratio multipliers and Helical bevel gearboxes

Technical data example Esempio di dati tecnici

Output speed n_2 [min ⁻¹]	Ratio i	Motor power P_{1M} [kW]	Output torque M_{2M} [Nm]	Service factor f.s	Nominal power P_{1R} [kW]	Nominal torque M_{2R} [Nm]	Flange code			Output shaft diam. Diam. albero uscita	Notes Note		
							B5 motor flanges	B14 motor flanges					
192	7.29	1.5	71	1.1	1.7	80	-	-	-Q 71	-R 80	-T 90	2811	01
125	11.20	1.5	110	1.2	1.8	130			C	C		288	02
106	13.18	1.5	129	1.0	1.5	130			C	C		1911	03
92	15.27	1.1	109	1.2	1.3	130			C	C		1711	04



Type of load and starts per hour Tipo di carico e avviamenti per ora	Ratio multipliers Riduttori ad uno stadio Helical bevel gearboxes Coppia conica			
Operating hours per day - Ore di funzionamento giornaliero	3h	10h	24h	
Continuous or intermittent application with start / hour Applicazione continua o intermittente con numero operazioni/ora ≤ 10	Uniform - <i>Uniforme</i>	0.8	1	1.25
	Moderate - <i>Moderato</i>	1	1.25	1.5
	Heavy - <i>Forte</i>	1.25	1.5	1.75
Intermittent application with start / hour Applicazione intermittente con numero operazioni/ora > 10	Uniform - <i>Uniforme</i>	1	1.25	1.5
	Moderate - <i>Moderato</i>	1.25	1.5	1.75
	Heavy - <i>Forte</i>	1.5	1.75	2.15

Required power - *Potenza richiesta*Lifting - *Sollevamento*Rotation - *Rotazione*Linear movement - *Traslazione*

$$P_{[kW]} = \frac{M_{[Kg]} \cdot g_{[9.81]} \cdot v_{[m/s]}}{1000}$$

$$P_{[kW]} = \frac{M_{[Nm]} \cdot n_{[rpm]}}{9550}$$

$$P_{[kW]} = \frac{F_{[N]} \cdot v_{[m/s]}}{1000}$$

Torque - *Coppia*

$$M_{[Nm]} = \frac{9550 \cdot P_{[kW]}}{n_{[rpm]}}$$

$$M_{[lb\ in]} = \frac{63030 \cdot P_{[HP]}}{n_{[rpm]}}$$

Radial loads - *Carichi radiali*

Radial load generated by external transmissions keyed onto input and/or output shafts.

Forza radiale generata da organi di trasmissione calettati sugli alberi di ingresso e/o uscita.

$$FR_{[N]} = \frac{M_{[Nm]} \cdot 2000}{d_{[mm]}} \cdot f_k$$

$$FR_{[N]} = \frac{M_{[lb\ in]} \cdot 8.9}{d_{[in]}} \cdot f_k$$

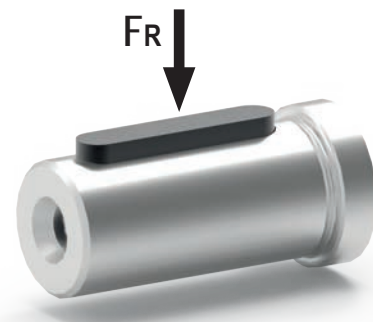
M: Output torque - *Momento torcente*d: Diam. of driving element - *Diametro primitivo*f_k: Factor - *Coefficiente di trasformazione*1.15: Gearwheels - *Ingranaggi*1.25: Chain sprockets - *Catena*1.75: Narrow v-belt pulley - *Cinghia Trapezoidale*2.50: Flat-belt pulley - *Cinghia piatta***If your application requires higher radial loads, contact our technical office. Higher loads may be possible.***Nel caso la vostra applicazione richieda carichi radiali superiori consultare il nostro ufficio tecnico, valori maggiori possono essere accettati.*

RAL 7035 painted Verniciato RAL 7035

Comparison on salt mist corrosion tests after 1000 hours.
Confronto sulle prove di corrosione in nebbia salina dopo 1000 ore.

0 hours

1000 hours

Standard
aluminum
worm gearboxes

*Riduttori a vite senza fine
in alluminio*



After short time it deteriorates
Dopo poco tempo si deteriorano



1000 hours

Same product
with white
protective paint

*Stesso prodotto con
vernice protettiva
bianca*



It allows acceptable results
Consente risultati accettabili



1000 hours

Two-component polyurethane product formulated with unmodified hydroxylated acrylic resin, to be crosslinked exclusively with an aliphatic isocyanic catalyst which gives rise to more elastic and non-yellowing films.

It can be applied in thick layers with limited solvent emission. This product guarantees excellent adhesion on steel, galvanized steel and other metals, excellent wetting of the substrate and high chemical resistance, hardness and flexibility.

The presence of zinc phosphate allows a high protection against anodic dissolution and delay in the formation of rust.

Show tolerance to non-optimal application and substrate conditions.

It remains strongly recommended where you want to offer high level protection in various painting cycles a different degree of resistance.

The primer also has, together with an excellent resistance to abrasion, a high adhesion.

Prodotto poliuretano bicomponente formulato con resina acrilica ossidrilata non modificata, da reticolare esclusivamente con catalizzatore isocianico alifatico che dà luogo a film più elastici e non ingiallenti.

Può essere applicato ad alto spessore con contenuta emissione di solventi.

Tale prodotto garantisce eccellente adesione su acciaio, acciaio zincato ed altri metalli, ottima bagnatura del substrato ed elevata resistenza chimica, durezza e flessibilità.

La presenza di fosfato di zinco permette un' elevata protezione contro la dissoluzione anodica e ritardo nella formazione della ruggine.

Mostra tolleranza a condizioni di applicazione e del supporto non ottimali.

Resta decisamente raccomandato ove si desideri offrire protezione ad alto livello in vari cicli di verniciatura a diverso grado di resistenza.

Il fondo possiede inoltre, unitamente ad un'ottima resistenza all'abrasione, una elevata adesione.

Finish <i>Aspetto</i>	Satin, 30-40 gloss according to ISO 2813 Satinato, 30-40 gloss secondo norma ISO 2813
Finish <i>Colore</i>	RAL 7035 Ral 7035
Specific gravity <i>Peso specifico</i>	1,44 ± 0,05 kg/dm ³ at 23°C, referring to 7721933 red RAL 3009 cured according to ISO 2811-1 1,44 ± 0,05 kg/dm ³ a 23°C, riferito al 7721933 rosso RAL 3009 catalizzato

NSS Neutral Salt Spray Test

Type DCTC 1200 P n° L79 SO 9227:2006 (E) with salt spray test: 5% NaCl

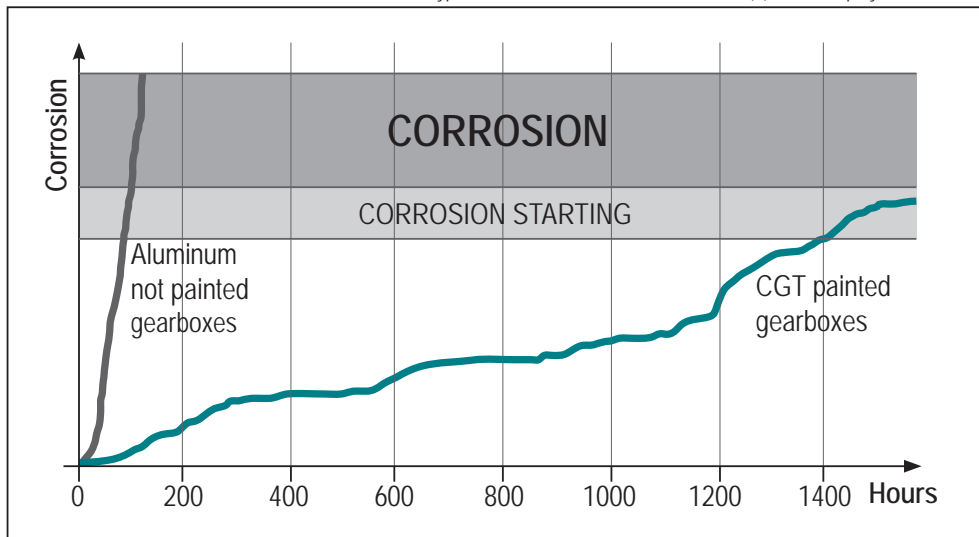

This graph is an indication, since some chemical components may be more aggressive than the salt spray test. Test are suggested on special cases (in case use type "N series", full stainless steel gearboxes).

Il grafico va considerato come indicativo perchè altri agenti chimici potrebbero risultare più aggressivi del test in nebbia salina. Sugeriamo prove specifiche nell'ambiente di lavoro e nel caso non vengano soddisfatti i requisiti minimi si consiglia di utilizzare la gamma in acciaio inox "Serie N".

Suggestions on application of the gearboxes

Suggerimenti sull'applicazione dei riduttori

Close protection cap

Coperchio di protezione chiuso

Closed protection cap seals the output hollow shaft end and provides protection against the rotating shaft. The cover can be mounted on both sides of the housing, matching screws are included in the scope of delivery.

Il coperchio di protezione chiuso sigilla l'estremità dell'albero cavo di uscita e fornisce protezione contro l'albero rotante. Il coperchio può essere montato su entrambi i lati dell'alloggiamento, le viti corrispondenti sono incluse nella fornitura.



Continuous duty on bevel gear

Servizio continuo su coppie coniche

If the application requires a gearbox for continuous duty operation, then choose a torque rating that is higher than the expected application torque and **avoid if possible vertical positions**.

For more information, contact our technical service.

Se l'applicazione richiede un riduttore per servizio continuo, sceglierne un valore di coppia superiore alla coppia di applicazione prevista evitare se possibile posizioni verticali.

Per maggiori informazioni, contattare il nostro servizio tecnico.



Input speed

Velocità di ingresso

When choosing a gearbox for a specific application, consider that with the input speed exceeding 1800 rpm, the temperature can rise.

Quando si sceglie un riduttore per un'applicazione specifica, considerare la velocità di ingresso superiore ai 1800 giri/min la temperatura può salire.



Coupling possible combination

Tabella combinazione giunti possibili

				GROUP	INPUT DIAMETER	Material	Kit Code	
ALUMINUM	STAINLESS STEEL				Ø			
D30	N30	I30	-	KA	09	P		
					K0305090P			
D45	N45	I45	X43N	KB	11	P		
					K0305091P			
					09	P		
KC355090P								
D50	N50	I50	-	KC	14	P		
					KC355092P			
					11	P		
					K0505091P			
19	Z							
K0505093Z								
D63	N63	I63	X42N	KD	11	P		
			X63N		KC405091P			
			X74N		14	P		
					KC405092P			
D85	N85	I85	X62N	KE	19	P		
			X73N		KC405093P			
					24	Z		
					KC405094Z			
					14	P		
					KC505092P			
					19	P		
					KC505093P			
					24	Z		
					KC505094Z			
					28	Z		
					KC505095Z			

Input coupling assembly *Montaggio Giunto in entrata*

PATENTED

The coupling is only suitable for the use of standard IEC / NEMA motors. The motor shaft must always have the shoulder to hold the coupling in position. The diameter of the coupling must always correspond to the IEC / NEMA flange applied to the reducer, reduced or increased dimensions of the hole are not allowed (ex. IEC 71 flange with hole $\varnothing 11$).

Il giunto è adatto solo per l'utilizzo di motori standard IEC / NEMA. L'albero motore deve avere sempre lo spallamento per tenere in posizione il giunto. Il diametro del giunto deve sempre corrispondere alla flangia IEC / NEMA applicata al riduttore, non sono consentite dimensioni ridotte o maggiorate del foro (es. flangia IEC 71 con foro $\varnothing 11$).

Direct mounting - No settings - No screw
Montaggio diretto - No settaggi - No viti

1



*** Do not mount oil seals on motor flange
Non montare anelli di tenuta nella flangia motore

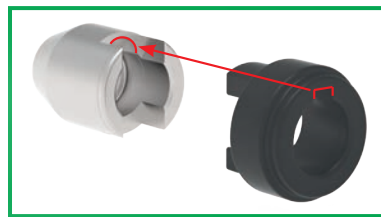

*

Motor shaft only allowed with shoulder

Usare un albero motore solo con spallamento

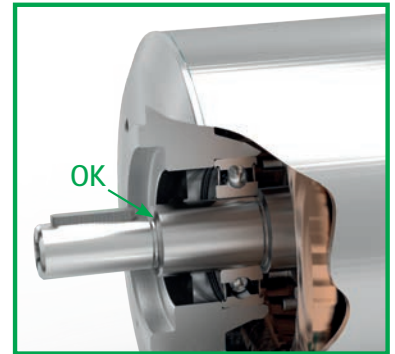

Do not use motor shaft without shoulder

Non utilizzare un albero motore senza spallamento

2

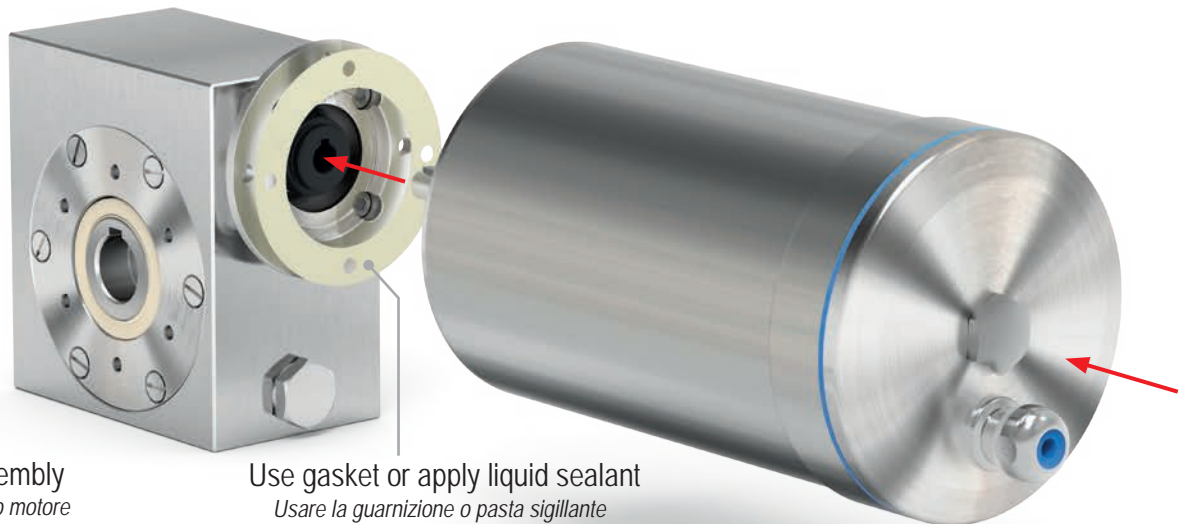

Motor assembly
Assemblaggio motore

Use gasket or apply liquid sealant
Usare la guarnizione o pasta sigillante

3

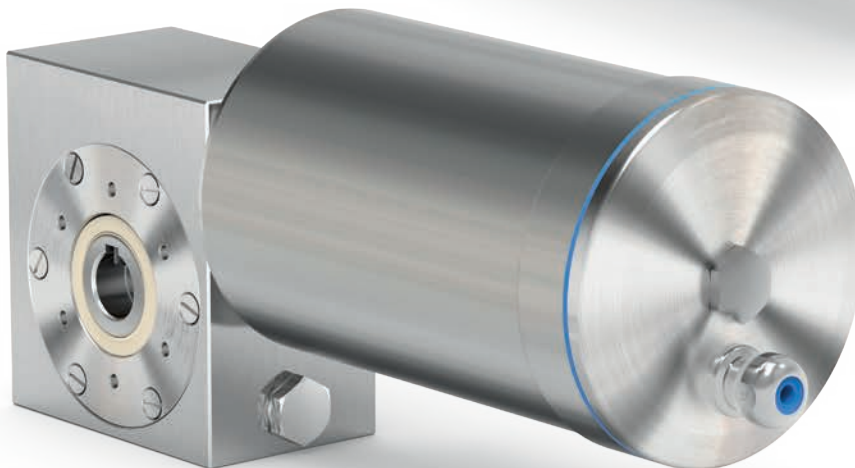

Available as an option for the motor range from IEC 56 to IEC 112
Disponibile come opzione per motori da IEC 56 a IEC 112

IP69K

IP69k is a rating of German standard DIN 40050-9 extending the IEC 60529 that provides the maximum protection degree against close range high pressure (100 bar), high temperature (80°C) spray downs, applied at a variety of angles, as well as against dust penetration. **In many industries, where dust and dirt can be an issue or where hygiene and cleanliness are essential, like in food and beverage industry, this certification is indispensable for the equipment that must be sanitized, withstanding rigorous high pressure and high temperature wash-down procedures.**

Il codice IP indica il grado di protezione del prodotto contro l'intrusione di particelle solide e di liquidi. IP69K è il massimo grado di protezione: contro la penetrazione della polvere e dei getti d'acqua/vapore ad alta pressione (100 bar) ed alta temperatura (80°C), da angolazioni differenti.

In molte industrie dove la polvere e la sporcizia possono essere un problema oppure dove l'igiene e la pulizia sono essenziali, come nell'industria alimentare, questa certificazione è indispensabile per la sanitizzazione dell'apparecchiatura, in grado di sopportare le procedure di lavaggio ad alta pressione e temperatura.



Products marked cRUus are certified to be manufactured in accordance with the requirements of UL and approved to be used in Usa and Canada.

This certification means that the products were tested and resulted compliant regarding potential flammability, electrical shock and mechanical hazard.

I prodotti marchiati cRUus hanno la certificazione di essere stati costruiti in accordo ai requisiti UL, sono approvati per l'uso Stati Uniti e Canada. Significa che sono stati testati e risultano idonei, in relazione ai loro potenziali rischi di incendio, shock elettrico e pericoli meccanici.



NTT™ stands for a special treatment which results in modified external properties of the mechanical parts with complex geometry.

It is a highly technological process which benefits from the expertise in many industrial and scientific fields. An excellent resistance to corrosion and long durability are the main features of NTT™ finishing, which makes NTT™ treated products a first choice and unique solution for variety of applications in many industries.

NTT™ è uno speciale trattamento che come risultato ha la modifica delle proprietà superficiali delle parti meccaniche con geometria complessa. E' un processo altamente tecnologico che trae benefici dalle competenze in vari campi sia industriali che scientifici. Ottima resistenza alla corrosione e durabilità sono le caratteristiche principali della finitura NTT™ che fa del trattamento la soluzione unica e di prima scelta per la molteplicità delle applicazioni in numerosi settori industriali.



By applying CE mark a manufacture declares the conformity of the product to the safety requirements settled in European regulations. It means that the product is compliant to all the directives of European Community regarding its usage: from design and manufacturing to release to the market, functioning and recycling.

Mediante l'applicazione della marcatura CE al prodotto, si dichiara alle autorità che esso è conforme ai requisiti di sicurezza previsti dalle norme Europee.

La marcatura CE indica che il prodotto è conforme a tutte le disposizioni della Comunità Europea che prevedono il suo utilizzo: dalla progettazione, alla fabbricazione, all'immissione sul mercato, alla messa in servizio del prodotto fino allo smaltimento.



IE mark indicates the efficiency class for electrical motor (Standard IEC 60034-30:2008 for three-phase low tension motors) “IE” code stands for “International Efficiency”:

IE1 = Standard Efficiency; IE2 = High Efficiency; IE3 = Premium Efficiency; IE4 = Super Premium Efficiency.

Starting from the 1st January 2017 IE3 efficiency is mandatory for the motors between 0,75 and 375 kW and IE2 in case the motor powered by inverter.

From 1 July 2021: the energy efficiency of three-phase motors with a rated output equal to or above 0,75 kW and equal to or below 1 000 kW, with 2, 4, 6 or 8 poles, shall correspond to at least the IE3 efficiency from 1 July 2023: the energy efficiency, with a rated output equal to or above 0,12 kW and equal to or below 1.000kW, with 2, 4, 6 or 8 poles, and single-phase motors with a rated output equal to or above 0,12 kW shall correspond to at least the IE2 efficiency, the energy efficiency of three-phase motors which are not brake motors, Ex eb increased safety motors, or other explosion-protected motors, with a rated output equal to or above 75 kW and equal to or below 200 kW, with 2, 4, or 6 poles, shall correspond to at least the IE4 efficiency .

Minimum efficiency class	For Motors	For AC drives
From July 2021	IE3	IE2
From July 2023	IE4 for motors rated 75-200kW	IE2

Con la sigla IE si definisce la classe di rendimento del motore elettrico (Norma IEC 60034-30:2008, per motori trifase a bassa tensione). Il Codice “IE” sta per “Efficienza Internazionale”:

IE1 = Rendimento Standard; IE2 = Rendimento Elevato; IE3 = Rendimento Premium; IE4 = Efficienza Super Premium.

Motori, inverter e sistemi di potenza sono classificati in base alla loro efficienza energetica.

Da gennaio 2015, in Europa, i nuovi motori IE2 devono essere controllati un variatore di velocità.

Da luglio 2021, il requisito minimo di efficienza dei motori elettrici è la classe IE3, mentre da luglio 2023 il requisito minimo per i motori nella gamma 75-200 kW è IE4.

Classe di efficienza:

A partire dal 1° luglio 2021, per l'immissione sul mercato e la distribuzione si applica quanto segue:

- Classe di efficienza IE2 (o superiore) per motori con una potenza nominale da 0,12 kW e inferiore a 0,75 kW
- Classe di efficienza IE3 (o superiore) per motori con una potenza nominale da 0,75 kW fino a 1.000 kW

Dal 1° luglio 2023, anche i motori con una potenza nominale di almeno 75 kW e fino a un massimo di 200 kW, immessi sul mercato e distribuiti, devono soddisfare i requisiti della classe di efficienza IE4 (o superiore).



ATEX abbreviation, which stands for French “Atmosphere Explosible”, identifies the Directive 2014/34/UE that replaced the previous 94/9/CE. The field of application of ATEX Directive extends to all equipment exploited in a potentially explosive environment on the territory of European Union. ATEX Directive appoints the notified European bodies (CESI, TÜV, KEMA, INERIS, Nemko, etc.) qualified for examination and verification of technical documentation, special testing and filing of relative documentation; once this procedure terminated successfully a manufacture is authorized to declare the conformity of its products to ATEX and use the ATEX mark on them.

Con ATEX si identifica la Direttiva 2014/34/UE, che ha sostituito la precedente 94/9/CE (il nome deriva dalla contrazione delle parole francesi “Atmosphere Explosible”). Il campo di applicazione della Direttiva ATEX comprende tutti gli apparecchi che devono essere installati, all'interno della Unione Europea, in ambienti potenzialmente a rischio di esplosione. La Direttiva ATEX stabilisce gli organismi europei notificati in EU (CESI, TÜV, KEMA, INERIS, Nemko, etc.) abilitati all'esame e verifica della documentazione tecnica, esecuzione di test specifici ed archiviazione della relativa documentazione; la procedura a seguito della quale, il produttore è autorizzato a rilasciare la dichiarazione di conformità dei propri prodotti alla normativa ATEX e l'utilizzo del marchio ATEX su di essi.



NSF International is an accredited, independent third-party certification organization that tests and certifies products to verify they meet these public health and safety standards. The NSF certification mark on a product means that the product complies with all standard requirements referring to the hygienic and health. NSF conducts periodic unannounced inspections and product testing to verify that the product continues to comply with the standard.

NSF International è un'organizzazione indipendente accreditata di certificazione che testa e certifica i prodotti per verificare che essi garantiscano i requisiti delle norme di Salute e Sicurezza. Il marchio NSF su un prodotto significa che il prodotto stesso è conforme agli standard richiesti in riferimento alle norme di igiene e salute. NSF esegue controlli periodici non annunciati per verificare che il prodotto continui ad essere conforme agli standard delle norme.

SINCE CLEAN-GEARTECH IS A DIVISION OF HYDRO-MEC SPA.
HYDROMECS SPA IS THE LEGAL RESPONSABLE FOR WARRANTY ISSUES.

PLEASE READ CAREFULLY

The following WARNING and CAUTION information are supplied to you for the proper functioning of your product.

Read ALL instructions prior to operating reducer.

Injury to personnel or reducer failure may be caused by improper installation, maintenance or operation.

WARNING:

- **Written authorization is required to operate or use reducers in man lift or people moving devices.**
- Check to make sure that certain applications do not exceed the allowable load capacities published in the current catalog.
- Buyer shall be solely responsible for determining the adequacy of the product for any and all uses to which Buyer shall apply the product. The application by Buyer shall not be subject to any implied warranty of fitness for a particular purpose.
- For safety, Buyer or User should provide protective guards over all shaft extensions and any moving apparatus mounted thereon. The User is responsible for checking all applicable safety codes in his area and providing suitable guards. Failure to do so may result in bodily injury and/or damage to equipment.
- Gearboxes operating in high position should have a protective shield for any possible parts falling down for casual accidents where people are moving under them.
- Hot oil and reducers can cause severe burns. Use extreme care when removing lubrication plugs and vents.
- Make certain that the power supply is disconnected before attempting to service or remove any components. Lock out the power supply and tag it to prevent unexpected application power.
- Reducers are not to be considered fail safe or self-locking devices. If these features are required, a properly sized, independent holding device should be utilized.
- Reducers should not be used as a brake.
- Any brakes that are used in conjunction with a reducer must be sized or positioned in such a way so as to not subject the reducer to loads beyond the catalog rating.
- Lifting supports including eyebolts are to be used for vertically lifting the gearbox only and not other associated attachments or motors.
- Use of an oil with an EP additive on units with backstops may prevent proper operation of the backstop. Injury to personnel, damage to the reducer or other equipment may result.
- Overhung loads subject shaft bearings and shafts to stress which may cause premature bearing failure and or shaft breakage from bending fatigue, if not sized properly.

SELLING CONDITIONS

Warranty for manufacturing defects will expire one-year after the invoicing date. Cleangeartech will replace or repair defective parts but will not accept any further changes for direct or indirect damages of any kind. The warranty will become null and void if repairs or changes are carried out without our prior written authorization.

Our company will not be responsible for any direct or indirect damages, caused by a wrong use of the products or for not observing the catalogue/web indication.

If the process requires total protections the customers should consider additional measures to avoid any contaminations arising from the gearboxes. All rights reserved.

All information shown in this catalogue are purely indicative; Hydro-Mec s.p.a reserves the right to make any necessary variation without prior notice.

CLEAN-GEARTECH È UNA DIVISIONE DI HYDRO-MEC SPA PER QUESTO MOTIVO HYDROMECS SPA È LEGALMENTE IL RESPONSABILE DEI PROBLEMI DI GARANZIA.

LEGGERE ATTENTAMENTE

Le seguenti raccomandazioni sono fondamentali per un buon funzionamento del vostro prodotto.

Leggere attentamente tutte le istruzioni prima di azionare il riduttore.

L'inappropriata installazione, manutenzione o funzionamento del riduttore può causare incidenti al personale addetto edanni al riduttore stesso.

ATTENZIONE:

- **E' richiesta autorizzazione scritta per azionare riduttori in ascensori o dispositivi per il movimento delle persone.**
- Controllare che alcune applicazioni non eccedano la massima capacità di carico ammessa pubblicata in questo catalogo.
- L'acquirente è l'unico responsabile per la determinazione dell'adeguatezza del prodotto per qualcuna o tutte le utilizzazioni che l'acquirente stesso farà del riduttore. L'applicazione dell'acquirente non potrà essere soggetta ad alcuna implicita garanzia di montaggio per uno scopo particolare.
- Per ragioni di sicurezza l'acquirente dovrà provvedere a porre protezioni adeguate su tutta la lunghezza dell'albero a tutti gli organi in movimento. L'utilizzatore è responsabile del controllo di tutti i codici di sicurezza e la predisposizione di protezioni adeguate. In assenza di tali precauzioni si possono verificare incidenti alle persone e danni agli apparati.
- Su riduttori installati in posizioni elevate utilizzare protezioni adeguate per qualsiasi distacco accidentale di parti nel caso di passaggio di persone al di sotto.
- Olio e riduttori bollenti possono causare gravi ustioni. Usare estrema cautela nella rimozione dei tappi e delle ventole.
- Assicurarsi che la corrente di alimentazione sia scollegata prima di riparare o rimuovere alcun componente. Chiudere l'alimentazione e contrassegnare tale operazione per evitare accensioni accidentali.
- I riduttori non devono essere considerati esenti da guasti o a bloccaggio automatico. Se sono indispensabili queste caratteristiche, deve essere utilizzato un dispositivo indipendente della dimensione adatta. I riduttori non devono essere utilizzati come freni.
- Qualsiasi freno sia utilizzato insieme al riduttore deve essere della giusta grandezza e posizionato in modo da non causare carichi eccessivi non previsti dai dati forniti nel catalogo.
- I dispositivi di sollevamento come le golfare devono essere usati solo per sollevare verticalmente il riduttore e non altri dispositivi associati o motori.
- L'utilizzo di un olio con un additivo EP su gruppi provvisti di dispositivo di arresto possono inficiare l'uso corretto del freno e provocare danni alle persone, alle cose ed al riduttore stesso nonché ad altri apparecchi.
- I Carichi sospesi assoggettano i cuscinetti della vite e la vite stessa a sollecitazioni che possono causare, se non adeguatamente dimensionati, l'usura prematura dei cuscinetti e/o l'arottura della vite a causa della resistenza alla flessione.

CONDIZIONI DI VENDITA

La garanzia relativa a difetti di costruzione ha la durata di un anno dalla data di fatturazione della merce. Tale garanzia comporta per Cleangeartech l'onere della sostituzione o riparazione delle parti difettose ma non ammette ulteriori addebiti per eventuali danni diretti o indiretti di qualsiasi natura. La garanzia decade nel caso in cui siano state eseguite riparazioni o apportate modifiche senza nostro consenso scritto.

La nostra ditta non si ritiene responsabile per eventuali danni diretti o indiretti derivanti da un uso improprio dei prodotti e dalla mancata osservanza delle indicazioni riportate a catalogo o web.

Se il processo richiede una protezione totale, i clienti dovrebbero prendere in considerazione misure aggiuntive per evitare qualsiasi contaminazione derivante dai riduttori.

Tutti i diritti sono riservati. Tutte le informazioni riportate nel presente catalogo sono puramente indicative; Hydro-Mec s.p.a si riserva il diritto di apportare qualsiasi variazione necessaria senza preavviso.

International General sales and warranty conditions

Quotations:

Unless differently agreed, the validity of all quotations is 2 months. The quotations are provided according the RFQ (request for quotation) which shall contain the complete and detailed specification of the Product, the correctness of which is fully under responsibility of RFQ applicant.

Orders:

Only official orders issued on the Customer's letter-head are accepted. The Order Confirmation (OC) is issued within few days from the order receipt unless the Products configuration issues arise. The OC shall be confirmed in writing within few working days from the OC date and in all its parts – the product code and description, quantities and price, other specific information, if any. The OC is considered confirmed by tacit approval in case no written confirmation is provided by the Customer within 7 days.

Production time:

The average production time for the standard Products is normally 3-4 weeks from the OC confirmation date and/or payment receipt in case of advanced payment term. For some configurations of the standard Products the production time can be longer and shall be advised in the quotation and/or in any case in OC. In the period of Christmas holidays and August holidays the days of company closure are excluded from the abovementioned production term. Possible delays due to production picks, do not give the buyer a right to require any kind of penalty or indemnity.

Delivery terms:

FCA Sovizzo, Italy (Incoterms 2016).

Packaging:

The products are packed in wooden boxes as a standard packaging. Europallets can be also used on request. The prices and details of the packaging are indicated in the specific section of the Price List.

Payment terms:

The payment should be performed in terms indicated in the invoice and by wire transfer.

Prices:

The prices are indicated in the invoice and intended ex-works, unless differently specified, and do not include any kind of taxes, shipment or other type of costs.

Standard Products orders cancellation:

Modification or cancellation of the orders is accepted only if notified to the Manufacturer in writing and not later than 5 days from the Order Confirmation and in any case before the production of the ordered Products is launched.

Special execution of customized products:

The Products that are not included in the catalogue or configurations of the products that can not be realized using catalogue, options and accessories brochure and/or online configurator are considered Customized Products.

- (a) The Manufacturer is entitled to examine feasibility of Special Execution of Customized Products and define the minimum quantity, production time and eventually other special sales and production conditions issuing thereafter a Special Execution Quotation that shall be confirmed by the Customer in writing.
- (b) Once the Quotation is confirmed, The Manufacturer shall realize a Special Execution (SE) data sheet with its unique code for each Customized product. The SE data sheet shall be confirmed in full and in writing by the Customer.

(c) The production time of SE is definitely settled by The Manufacturer and notified to the Customer after the SE data sheet confirmation. As a rule, the production time for SE of Customized products is longer than standard.

(d) The orders of Special Execution of Customized products cannot be cancelled unless special written agreement is made before the production of SE is launched.

WARRANTY Conditions:

(a) Warranty period is 12 months from the shipment date.

(b) Warranty period could be extended to 18 months prior written agreement of the parties and in any case excluding wearable parts.

(c) Warranty covers only manufacturing defects. Wearable parts (for example, oil seals or lubricants leakages caused by normal wear) and failures due to the wrong assembling by the Customer are not covered by warranty.

(d) This warranty is also void in any case in which the products have been misused, used in improper environment conditions, configured beyond design limits indicated in the catalogue (especially service factor, loads and type of motors) or damaged, even accidentally or whenever installation instructions have not been strictly followed and in case of any natural disasters, in case of negligence of the Customer and the end user.

(e) The Customer is fully responsible to assure the compatibility of applications and correct mechanical couplings and electrical connections with the specifications of the Products according to The Manufacturer catalogues and technical documentation

(f) The liability of The Manufacturer is strictly limited to the above-stated obligations and it is therefore clearly agreed that The Manufacturer takes no responsibility for any damage to persons and/or property deriving from accidents of any nature that may occur during use of the Products, whether the warranty is confirmed or otherwise, also in cases of the choice of the Product configuration being recommended by The Manufacturer.

WARRANTY Procedure:

(a) The Customer shall fill in the COMPLAINT FORM and forward it to The Manufacturer along with other relevant information.

(b) The Manufacturer examines the COMPLAINT FORM and confirms or declines the warranty.

(c) The Manufacturer has the right to ask the Customer to send the malfunctioning product back to the Seller for further examination. In case the warranty is not confirmed the Product will be shipped back to the Customer at the Customer expense. If the warranty is confirmed, The Manufacturer shall compensate the shipment costs to the Customer within the limits of the best shipment quotation.

(d) In case the warranty is confirmed the Products shall be substituted at The Manufacturer's expense using ordinary shipment procedure. The express shipment can be used prior the agreement of the parties.

(e) In case the Product cannot be substituted The Manufacturer shall reimburse the value of the Product by issuing of Credit Note or in any other way agreed by the Parties.

1) Definizioni

1.1 Ai fini delle presenti condizioni generali di vendita (di seguito denominate "Condizioni di Vendita"), i seguenti termini avranno il significato di seguito ad essi attribuito:

- "Cliente": qualunque società, ente o entità giuridica che acquisti i nostri prodotti;
- "Prodotti": i nostri beni prodotti, assemblati e/o venduti;
- "Ordine/i": ciascuna proposta di acquisto dei Prodotti inoltrata dal Cliente esclusivamente tramite e-mail, fax o web;
- "Vendita/e": ciascun contratto di vendita concluso a seguito del ricevimento da parte del Cliente dell'accettazione scritta dell'Ordine da parte nostra;

2) Scopi

2.1 Le presenti Condizioni di Vendita si applicano a tutte le Vendite di Prodotti. Nel caso di contrasto tra le condizioni e i termini di cui alle presenti Condizioni di Vendita e le condizioni e i termini pattuiti nella singola Vendita, quest'ultimi prevarranno. Non saremo vincolati da condizioni generali di acquisto del Cliente (di seguito, "CGA"), neanche nell'ipotesi in cui si faccia loro riferimento o siano contenute negli ordini o in qualsiasi altra documentazione di provenienza del Cliente, senza il preventivo consenso scritto. Le CGA non saranno vincolanti neppure per effetto di tacito consenso.

2.2 Ci riserviamo il diritto di aggiungere, modificare o eliminare qualsiasi previsione delle presenti Condizioni di Vendita, restando inteso che tali aggiunte, modifiche o cancellazioni si applicheranno a tutte le Vendite concluse a partire dal trentesimo giorno successivo alla notifica al Cliente delle nuove Condizioni di Vendita.

3) Ordini e Vendite

3.1 Il Cliente dovrà inoltrarci Ordini specifici contenenti la descrizione dei Prodotti, la quantità richiesta, il prezzo ed i termini richiesti per la consegna.

3.2 La Vendita dovrà ritenersi conclusa: (i) nel momento in cui il Cliente riceva una nostra conferma scritta (tale conferma potrà essere inviata via e-mail, fax o mezzi telematici) conforme ai termini e alle condizioni dell'Ordine (ii) o, nel caso in cui il Cliente riceva da parte nostra una conferma scritta contenente termini difformi da quelli contenuti nell'Ordine, decorsi tre giorni lavorativi dalla data di ricezione della conferma contenente termini difformi senza che nel suddetto periodo ci pervenga contestazione scritta da parte del Cliente; (iii) o, in assenza di conferma scritta da parte nostra, nel momento in cui i Prodotti saranno consegnati al Cliente.

3.3 Gli Ordini regolarmente accettati non potranno essere annullati dal Cliente senza il nostro consenso scritto.

4) Prezzo dei Prodotti

4.1 I prezzi dei Prodotti saranno quelli indicati nel nostro listino prezzi in vigore al momento dell'inoltro dell'Ordine da parte del Cliente o, qualora il Prodotto non sia inserito nel listino prezzi o il listino prezzi non sia disponibile, quelli indicati nell'Ordine e confermati per iscritto al momento dell'accettazione dell'Ordine. Eccetto quanto diversamente concordato per iscritto tra le parti, i predetti prezzi saranno calcolati franco fabbrica, al netto dell'IVA e degli sconti. Tali prezzi non comprendono i costi di imballaggio, spedizione e trasporto dai nostri locali a quelli del Cliente. Tali costi dovranno essere sostenuti separatamente dal Cliente.

4.2 Manterremo la proprietà dei Prodotti fino alla completa corresponsione del prezzo degli stessi. Il Cliente dovrà compiere tutti gli adempimenti richiesti dalle leggi locali al fine di rendere valida ed eseguibile nei confronti di tutti i terzi la presente clausola di riserva della proprietà anche operando l'iscrizione in ogni apposito registro, ove localmente richiesto.

5) Termini di consegna

5.1 Eccetto quanto eventualmente diversamente concordato per iscritto tra le parti, consegneremo i prodotti franco fabbrica presso i propri stabilimenti, così come questo termine è definito negli INCOTERMS 2010 pubblicati dalla Camera di Commercio internazionale nella loro versione più aggiornata, in vigore al momento della consegna. Se richiesto, ci occuperemo del trasporto dei Prodotti a rischio, costi e spese del Cliente.

5.2 La consegna dovrà avvenire entro il termine indicato nell'Ordine come accettato nella conferma d'ordine. I termini di consegna sono indicativi e non sono termini essenziali ai sensi dell'art. 1457 del Codice Civile e, in ogni caso, non includono i tempi di trasporto.

5.3 Salvo quanto previsto dal precedente art. 5.2, non saremo considerati responsabili dei ritardi o della mancata consegna ascrivibili a circostanze che siano fuori dal suo controllo, quali a titolo meramente esemplificativo e senza pretesa di esaustività:

- a) dati tecnici inadeguati o imprecisioni o ritardi del Cliente nella trasmissione di informazioni o dati necessari alla spedizione dei Prodotti;
- b) difficoltà nell'ottenere rifornimenti delle materie prime;
- c) problemi legati alla produzione o alla pianificazione degli ordini;
- d) scioperi parziali o totali, mancanza di energia elettrica, calamità naturali, misure imposte dalle autorità pubbliche, difficoltà nel trasporto, cause di forza maggiore, disordini, attacchi terroristici e tutte le altre cause di forza maggiore;
- e) ritardi da parte dello spedizioniere.

5.4 Il verificarsi di alcuni degli eventi sopra elencati non darà diritto al Cliente di richiedere il risarcimento degli eventuali danni o indennizzi di alcun genere.

6) Trasporto

6.1 Eccetto quanto eventualmente diversamente concordato per iscritto tra le parti, il trasporto avverrà sempre a spese e rischio del Cliente. Nel caso in cui, ai sensi dell'art. 5.1, ci venga richiesto di occuparsi del trasporto dei Prodotti, sceglieremo il mezzo di trasporto che si riterrà più appropriato in mancanza di specifiche istruzioni del Cliente.

7) Pagamenti

7.1 Salvo diverso accordo scritto tra le parti, emetteremo le fatture al momento della consegna dei Prodotti.

7.2 Il mancato pagamento nel tempo concordato ci darà diritto a di chiedere al Cliente il pagamento degli interessi scaduti al tasso stabilito dal Decreto Legislativo n. 231/02.

7.3 Il mancato pagamento o il ritardo nei pagamenti superiore a 30 giorni ci daranno il diritto di sospendere la consegna dei Prodotti e risolvere ogni singola Vendita sottoscritta. La sospensione della consegna dei Prodotti o la risoluzione delle Vendite non darà il diritto al Cliente di pretendere alcun risarcimento dei danni.

7.4 Ogni reclamo relativo ai Prodotti e/o alla consegna dei medesimi non potrà in alcun caso giustificare la sospensione o il ritardo nel pagamento.

8) Non-conformità

8.1 Qualsiasi difformità dei Prodotti consegnati al Cliente rispetto al tipo ed alla quantità indicata nell'Ordine ci dovrà essere denunciata per iscritto entro cinque giorni dalla data di consegna. Qualora la denuncia non venga comunicata entro il predetto termine, i Prodotti consegnati verranno considerati come conformi a quelli ordinati dal Cliente.

9) Garanzia

9.1 Salvo diverso accordo scritto tra le parti, garantiamo che i Prodotti sono esenti da vizi/difetti (con esclusione di quelle parti dei Prodotti che non sono di nostra produzione) per un periodo di 12 mesi decorrente dalla data di consegna dei medesimi al Cliente.

9.2 La garanzia non opererà con riferimento a quei Prodotti i cui difetti sono dovuti a (i) danni causati durante il trasporto; (ii) un uso negligente o improprio degli stessi; (iii) inosservanza delle nostre istruzioni relative al funzionamento, manutenzione ed alla conservazione dei Prodotti; (iv) riparazioni o modifiche apportate dal Cliente o da soggetti terzi senza la previa autorizzazione scritta.

9.3 A condizione che il reclamo del Cliente sia coperto dalla garanzia e notificato nei termini di cui al presente articolo, ci impegneremo, a nostra discrezione, a sostituire o riparare ciascun Prodotto o le parti di questo che presentino vizi o difetti.

9.4 Il Cliente dovrà denunciare per iscritto, la presenza di vizi o difetti entro 8 giorni dalla consegna dei Prodotti se si tratta di vizi o difetti palesi, oppure, entro 8 giorni dalla scoperta in caso di vizi o difetti occulti o non rilevabili da una persona di media diligenza.

9.5 I Prodotti oggetto di denuncia dovranno essere immediatamente inviati presso la nostra fabbrica, o in qualsiasi altro luogo che quest'ultima indicherà di volta in volta, a costi e spese a carico del Cliente salvo diverso accordo tra le parti, al fine di consentire l'espletamento dei necessari controlli. La garanzia non copre danni e/o difetti dei Prodotti derivanti da anomalie causate da, o connesse a, parti assemblate/aggiunte direttamente dal Cliente o dal consumatore finale. Qualora, nell'ambito della presente garanzia, un Prodotto o un componente difettoso venisse sostituito, la proprietà del Prodotto o del componente sostituito sarà ritrasferita dal Cliente a noi.

9.6 In ogni caso il Cliente non potrà far valere i diritti di garanzia se il prezzo dei Prodotti non sia stato corrisposto alle condizioni e nei termini pattuiti, anche nel caso in cui la mancata corresponsione del prezzo alle condizioni e nei termini pattuiti si riferisca a Prodotti diversi da quelli per i quali il Cliente intende far valere la garanzia.

9.7 Non riconosciamo alcuna garanzia circa la conformità dei Prodotti alle norme e ai regolamenti di Paesi che non rientrano o non appartengono all'Unione Europea. Nessun'altra garanzia, espressa o implicita, quale, a titolo esemplificativo, la garanzia di buon funzionamento o di idoneità per uno scopo specifico, è concessa con riferimento ai Prodotti.

9.8 Senza pregiudizio a quanto indicato nel precedente art. 9.3 e salvo il caso di dolo o colpa grave, non saremo responsabili per qualsivoglia danno derivante e/connesso ai vizi dei Prodotti. In ogni caso, non saremo ritenuti responsabili per danni indiretti o consequenziali di qualsiasi natura quali, a titolo esemplificativo, le perdite derivanti dall'inattività del Cliente o il mancato guadagno.

10) Diritti di Proprietà Intellettuale

10.1 I Diritti di Proprietà Intellettuale sono di totale ed esclusiva nostra proprietà e la loro comunicazione o utilizzo nell'ambito delle presenti Condizioni di Vendita non crea, in relazione ad essi, alcun diritto o pretesa in capo al Cliente. Il Cliente si obbliga a non compiere alcun atto incompatibile con la titolarità dei Diritti di Proprietà Intellettuale.

11) Clausola risolutiva espressa

11.1 Avremo facoltà di risolvere, ai sensi e per gli effetti dell'art. 1456 del Codice Civile Italiano, in qualsiasi momento mediante comunicazione scritta da inviare al Cliente, la singola Vendita nel caso di inadempimento delle obbligazioni previste dagli articoli: 4 (Prezzo dei Prodotti); 7 (Pagamenti); 10 (Diritti di Proprietà Intellettuale).

12) Mutamento nelle condizioni patrimoniali del Cliente

12.1 Avremo diritto a sospendere l'adempimento delle obbligazioni derivanti dalla Vendita dei prodotti, in base all'art. 1461 del Codice Civile Italiano, nel caso in cui le condizioni patrimoniali del Cliente divenissero tali da porre in serio pericolo il conseguimento della controprestazione salvo che sia prestata idonea garanzia.

13) Domicilio legale, legge applicabile e giurisdizione

13.1 Siamo legalmente domiciliati presso la nostra sede principale.

13.2 Le Condizioni di Vendita e ogni singola Vendita saranno regolate e interpretate in conformità alla Legge Italiana.

13.3 Tutte le controversie derivanti da o connesse alle presenti Condizioni di Vendita e/o ad ogni Vendita saranno soggette alla esclusiva giurisdizione del Tribunale di Vicenza.

13.4 Salvo quanto pattuito nel precedente art. 13.3, ci riserviamo il diritto, quando promotore di una azione legale in qualità di attore, di promuovere tale azione nel luogo di residenza del Cliente.



CLEAN-GEARTECH

Via Cordellina, 81, 36077 Altavilla Vicentina VI - ITALY
Tel. +39 0444 1240920 - Fax +39 0444 1240921
info@cleangeartech.com - www.cleangeartech.com

a division of **HYDRO-MEC**

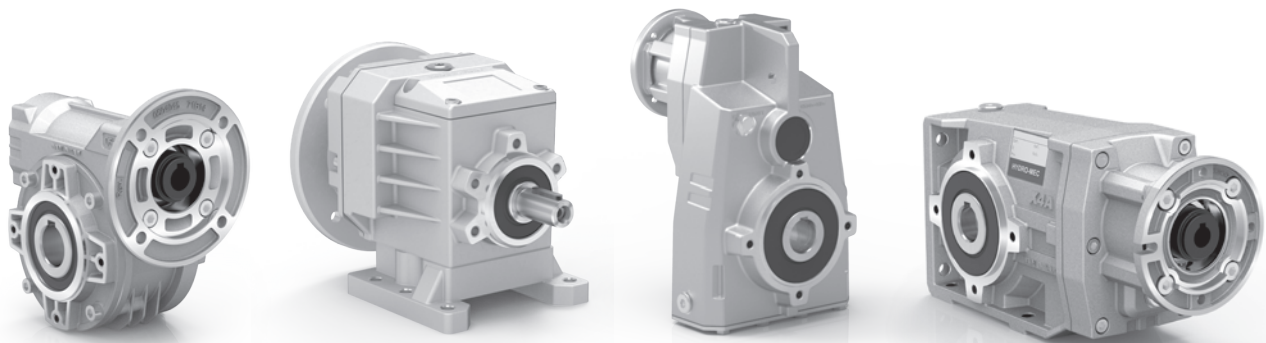

THE MODULAR GEARBOXES www.hydromec.com

ATLANTA Drive Systems Inc.
1775 Route 34, Unit D-10
Farmingdale, NJ 07727

Phone: (800) 505-1715
Email: info@atlantadrives.com
Website: www.atlantadrives.com