



Center Distance

$a_0 = 50 \text{ mm}$

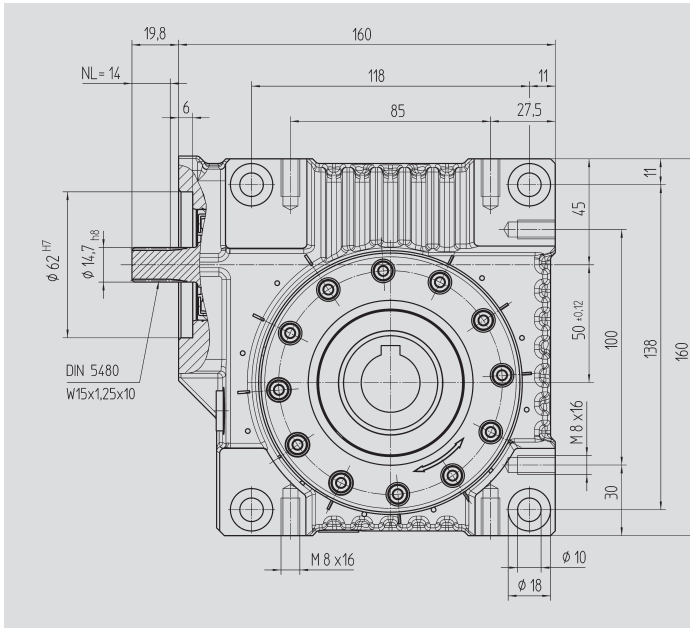

Fig. 1 Output shaft with key connection

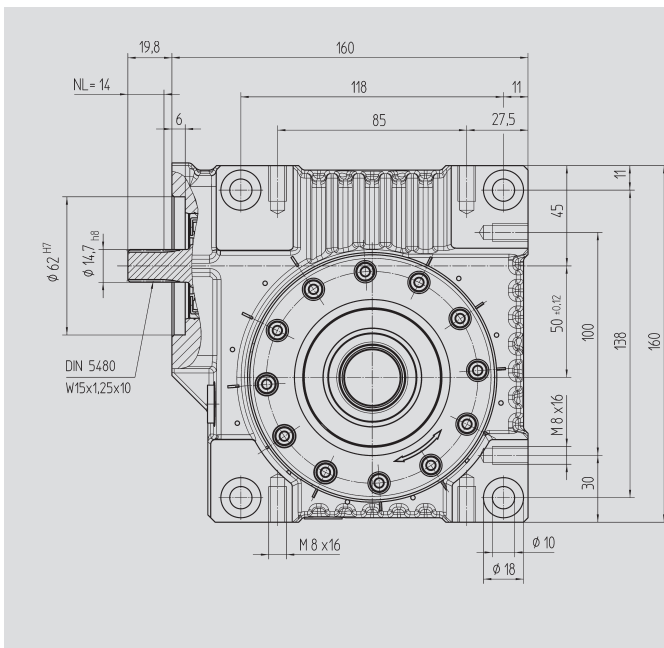
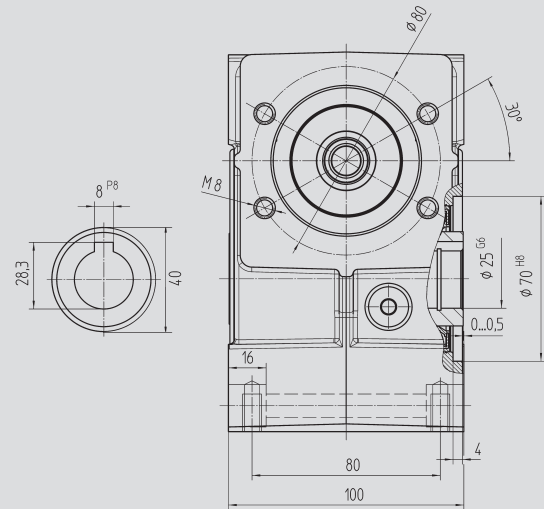
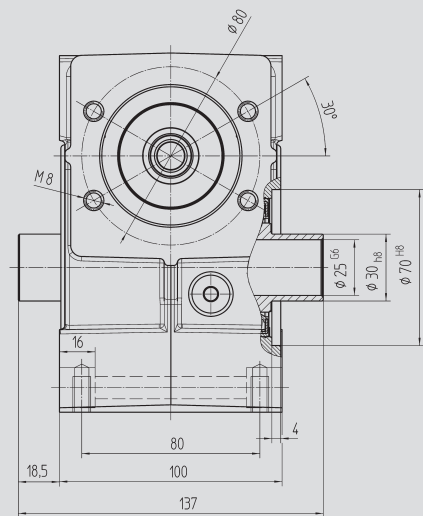

Fig. 2 Output shaft for clamp connection 80 83 030



Order Code
Fig. 1

Fig. 2

Ratio i



J_{red} 10⁻⁴
kg m²

58 03 005	58 13 005	4.75	6.5	0.8280
58 03 007	58 13 007	6.75	6.5	0.4140
58 03 009	58 13 009	9.25	6.5	0.3490
58 03 015	58 13 015	14.50	6.5	0.2800
58 03 020	58 13 020	19.50	6.5	0.1960
58 03 029	58 13 029	29.00	6.5	0.2694
58 03 039	58 13 039	39.00	6.5	0.2310
58 03 050	58 13 050	50.00	6.5	0.2140

With food grade oil, order code 58 03 1xx / 58 13 1xx

With ATEX version with food grade oil, order code 58 03 2xx / 58 13 2xx



Motor Flange

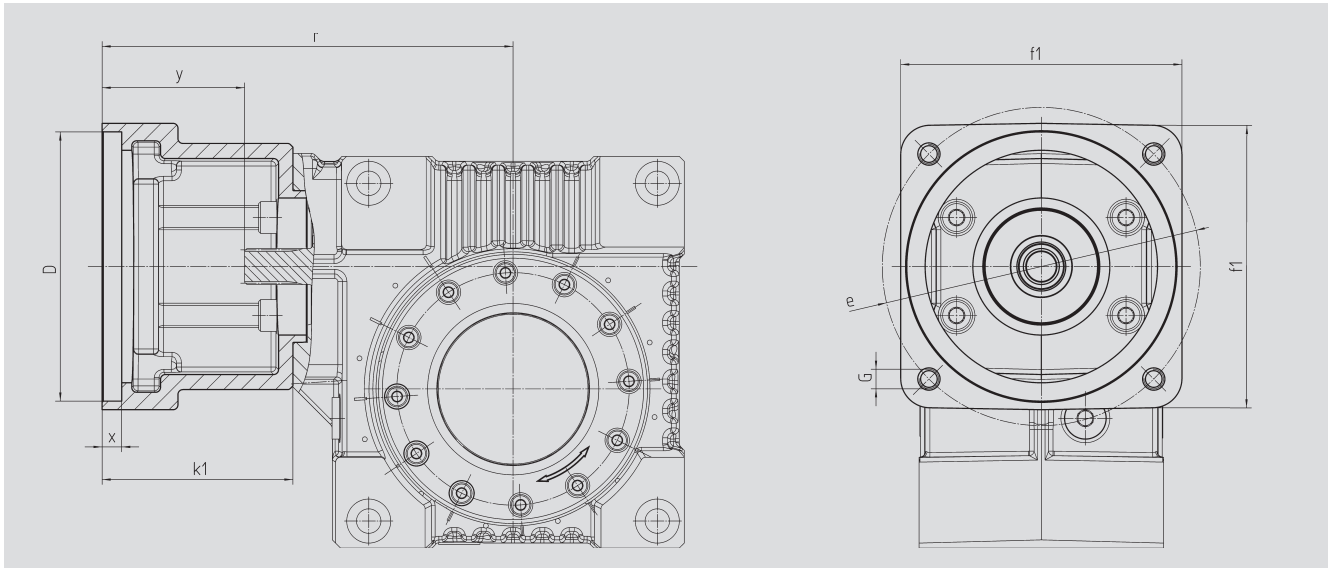

Center Distance

$a_o = 50 \text{ mm}$

Order Code	D ^{G7}	k ₁	r	x	y	f ₁	e	G	kg
65 59 301	95.0	62	152	12.5	42	100	115	M8	0.60
65 59 302	50.0	62	152	10.0	42	100	70, 95, 115	M4, M6, M8	0.70
65 59 303	80.0	62	152	10.0	42	100	100	M6	0.65
65 59 304	95.0	78	168	10.0	58	115	130	M8	0.80
65 59 305	95.0	72	162	8.0	52	100	115	M8	0.75
65 59 306	60.0	74	164	21.0	54	100	75, 90, 115	M5, M5, M8	0.90
65 59 307	70.0	70	160	21.0	50	100	90, 115	M6, M8	0.80
65 59 401	95.0	73	163	8.0	53	100	115	M8	0.75
65 59 402	110.0	78	168	8.0	58	115	130	M8	0.80
65 59 403	95.0	73	163	12.0	53	115	130	M8	0.75
65 59 404	110.0	73	163	12.0	53	115	130	M8	0.70
65 59 405	95.0	78	168	11.0	58	140	165	M10	1.20
65 59 406	110.0	78	168	11.0	58	140	165	M10	1.15
65 59 407	130.0	78	168	11.0	58	140	165	M10	1.00
65 59 409	130.0	98	188	14.0	78	140	165	M10	1.10
65 59 410	110.0	74	164	8.0	54	120	145	M8	1.00
65 59 411	110.0	84	174	8.0	64	120	145	M8	1.20
65 59 412	114.3	105	195	8.0	85	180	200	M12	3.70
65 59 413	114.3	139	229	8.0	119	180	200	M12	3.35
65 59 414	114.3	91	181	8.0	71	180	200	M12	2.65
65 59 415	110.0	89	179	8.0	69	120	145	M8	1.30

The order should contain gear box 58 03 0xx / 58 13 0xx and flange 65 59 3xx or 4xx.